

Guidance Notes on

---

# Strength Assessment of Independent Type C Tanks



January 2022



GUIDANCE NOTES ON

STRENGTH ASSESSMENT OF INDEPENDENT TYPE C  
TANKS  
JANUARY 2022

American Bureau of Shipping  
Incorporated by Act of Legislature of  
the State of New York 1862

© 2022 American Bureau of Shipping. All rights reserved.  
ABS Plaza  
1701 City Plaza Drive  
Spring, TX 77389 USA

## Foreword

In recent years, the market demand for small and medium gas carriers/bunkers/barges has increased for short/medium distance trade. One of the promising solutions to meet this growing need is to use independent Type C tanks for gas vessels. For example, a typical bi-lobe Type C gas carrier has four bi-lobe tanks installed on board, and each tank has two end saddle supports. The requirements in the International Code for the Construction and Equipment of Ships Carrying Liquefied Gases in Bulk (IGC Code) should be satisfied for the design of independent Type C liquefied gas cargo tanks.

On the other hand, using natural gas (NG) as a marine fuel has become very attractive across the globe. Thus, more and more NG fueled ships equipped with independent Type C fuel tanks have been built. On gas fueled ships, the vacuum-insulated Type C gas fuel tank with double shells is the most popular design for the gas fuel containment system. The Type C fuel tanks must satisfy the International Code of Safety for Ships Using Gases or Other Low Flashpoint Fuels (IGF Code) requirements.

In general, independent Type C tanks are also known as “pressure vessels” which are designed and built to meet the requirements of recognized pressure vessel standards such as the ASME Boiler and Pressure Vessel Code (BPVC), as well as additional classification society requirements and statutory regulations.

These Guidance Notes provide the procedures for determining design loads on the Type C tanks and performing the strength evaluation of tank and supporting structures. Type C tanks herein include liquefied gas cargo tanks on carriers, barges, or offshore terminals and liquefied gas fuel tanks on gas fueled ships. The technical approach adopted in these procedures is based on the direct calculation method using the finite element (FE) analysis to assess tank and supporting structures subject to static and dynamic loads. Design load cases including standard load conditions, accidental load conditions, and test load conditions are defined for the yielding, buckling, and fatigue evaluation. Finally, a strength assessment procedure for different failure modes is provided for tank and supporting structures.

Refer to the *ABS Guide for Building and Classing Liquefied Gas Carriers with Independent Tanks* for the requirements for the strength of hull structures of independent type gas carriers. For guidance on propulsion and auxiliary systems for gas fueled ships, see Part 5C, Chapter 13 of the *ABS Rules for Building and Classing Marine Vessels (Marine Vessel Rules)*.

The effective date of these Guidance Notes is the first day of the month of publication.

Users are advised to check periodically on the ABS website [www.eagle.org](http://www.eagle.org) to verify that this version of these Guidance Notes is the most current.

*We welcome your feedback. Comments or suggestions can be sent electronically by email to [bowang@eagle.org](mailto:bowang@eagle.org).*

### Terms of Use

The information presented herein is intended solely to assist the reader in the methodologies and/or techniques discussed. These Guidance Notes do not and cannot replace the analysis and/or advice of a qualified professional. It is the responsibility of the reader to perform their own assessment and obtain professional advice. Information contained herein is considered to be pertinent at the time of publication but may be invalidated as a result of subsequent legislations, regulations, standards, methods, and/or more updated information and the reader assumes full responsibility for compliance. Where there is a conflict between this document and the applicable ABS Rules and Guides, the latter will govern. This publication may not be copied or redistributed in part or in whole without prior written consent from ABS.



GUIDANCE NOTES ON

# STRENGTH ASSESSMENT OF INDEPENDENT TYPE C TANKS

## CONTENTS

<b>SECTION 1</b>	<b>Introduction.....</b>	<b>5</b>
1	General.....	5
2	Marine and Offshore Applications.....	7
3	Abbreviations.....	8
4	Overview of Strength Evaluation of Independent Type C Tanks.....	8
	FIGURE 1 Type C Cylindrical and Bi-Lobe Tanks.....	6
	FIGURE 2 Global FE Model for a Bi-lobe Gas Carrier.....	7
	FIGURE 3 Type C Vacuum-Insulated Fuel Tanks.....	7
	FIGURE 4 Flowchart of Structural Integrity Assessment.....	10
<b>SECTION 2</b>	<b>Loads and Design Load Cases.....</b>	<b>11</b>
1	General.....	11
2	Loads and Design Load Cases.....	12
2.1	Static and Dynamic Loads.....	12
2.2	Design Load Cases.....	27
	TABLE 1 Design Load Cases for Fatigue Strength Assessment (Acceleration Factors for Full & Ballast Load Conditions)....	30
	FIGURE 1 Deflection of Ship Structure from Global FE Modeling.....	15
	FIGURE 2 Acceleration Ellipsoid and Ellipse.....	19
	FIGURE 3 Determination of Internal Pressure Heads.....	21
	FIGURE 4 YZ Plane for a Bi-Lobe Tank.....	23
	FIGURE 5 XZ Plane for a Bi-Lobe Tank.....	24
	FIGURE 6 Definition of Tank Geometry.....	25
	FIGURE 7 CFD Sloshing Simulation in a Bi-Lobe Tank.....	26
	FIGURE 8 CFD Sloshing Simulation in a Fuel Tank.....	27
<b>SECTION 3</b>	<b>Structural Analysis of Tank and Supporting Structures.....</b>	<b>31</b>

1	General.....	31
2	Finite Element (FE) Modeling.....	31
3	Loading and Boundary Conditions.....	32
4	Stress Analysis.....	32
5	Buckling Analysis.....	33
6	Fatigue Analysis.....	34
6.1	High Cycle Fatigue.....	37
6.2	Low Cycle Fatigue.....	38
FIGURE 1	Example of Buckling Mode for a Bi-Lobe Tank.....	33
FIGURE 2	Example of Buckling Mode of a Vacuum-Insulated Tank under Overpressure.....	34
FIGURE 3	FE Mesh for a Bi-Lobe Tank.....	35
FIGURE 4	FE Mesh near Y- Joint for a Bi-Lobe Tank.....	36
FIGURE 5	Vacuum-Insulated Double Shell Tank.....	37
<b>SECTION 4</b>	<b>Strength Assessment of Type C Tank and Supporting Structures.....</b>	<b>39</b>
1	General.....	39
2	Yielding Evaluation.....	39
3	Buckling Evaluation.....	40
4	Fatigue Evaluation.....	41
5	<b>Strength Evaluation of Supporting Structures.....</b>	<b>42</b>
TABLE 1	Values of A and B for Determination of Allowable Stress Criteria.....	40
<b>APPENDIX 1</b>	<b>References.....</b>	<b>43</b>
<b>APPENDIX 2</b>	<b>Material Properties.....</b>	<b>44</b>
1	Austenitic SS304 Stainless Steel Mechanical Properties.....	44
2	Aluminum Alloy (5083-O) Mechanical Properties.....	44
3	9% Nickel Steel Mechanical Properties.....	44
4	5% Nickel Steel Mechanical Properties.....	45
5	Aluminum Alloy (6061-T6) Mechanical Properties.....	45
6	Austenitic SS316 Stainless Steel Mechanical Properties.....	45

## **1 General**

As energy demand increases there is a commensurate increase in the need for liquefied gas carriers/bunkers/barges. These include liquefied natural gas (LNG), liquefied petroleum gas (LPG) and liquefied ethane gas (LEG) vessels. Liquefied gas fuel tanks will be needed for gas transportation and gas fueled ships, respectively. As described in the International Code for the Construction and Equipment of Ships Carrying Liquefied Gases in Bulk (IGC Code) and the International Code of Safety for Ships using Gases or other Low-flashpoint Fuels (IGF Code), there are several categories of cargo/fuel containment systems including membrane type and independent type (Type A, Type B, and Type C) systems.

Among the very large LNG cargo vessel fleet, the most common tank type is the membrane-type LNG vessel, in which the tank is directly formed by the inner hull structure. For this type of vessel, sloshing is a key issue since it could potentially cause damage to the cargo containment systems due to the smooth surfaces inside the tank.

Other types of large liquefied gas carriers are independent Type B, including spherical and prismatic vessels. They are designed to minimize sloshing loads using a spherical shape or the internal member structures inside the Type B containment system. For large LPG vessels, the independent Type A tank is usually applied utilizing the hull structure as the full secondary barrier.

In recent years, the small-scale liquefied gas cargo market has expanded for short/medium distance transportation (e.g., domestic trade). One of the promising solutions to meet this growing need is to use an independent Type C containment system, which is commonly used for small scale liquefied gas cargo transportation. For example, for a bi-lobe Type C LNG/LPG/LEG vessel, there may be four bi-lobe tanks installed inside a carrier, with each tank possessing end saddle supports. One end is fixed (all degrees of freedom are restrained) and the other end is designed to be able to slide in a longitudinal direction to compensate for the effect of thermal contraction/expansion caused by the temperature change of the tanks.

The global shipping industry also faces a challenge as legislation for Emission Control Areas (ECA) has limited the allowable sulfur emissions of ships significantly, firstly in North America and northern Europe. Natural gas is a potential solution for meeting these emission requirements since it is a cleaner burning fuel which can reduce sulfur oxide (SO<sub>2</sub>) emissions by 90% to 95% and carbon dioxide (CO<sub>2</sub>) emissions by 20% to 25%. Emission regulations have promoted the use of alternative marine fuels, such as natural gas. Most early adopters of natural gas as fuel have utilized Type C fuel containment systems, considering the advantages of boil-off gas management and associated operational flexibility.

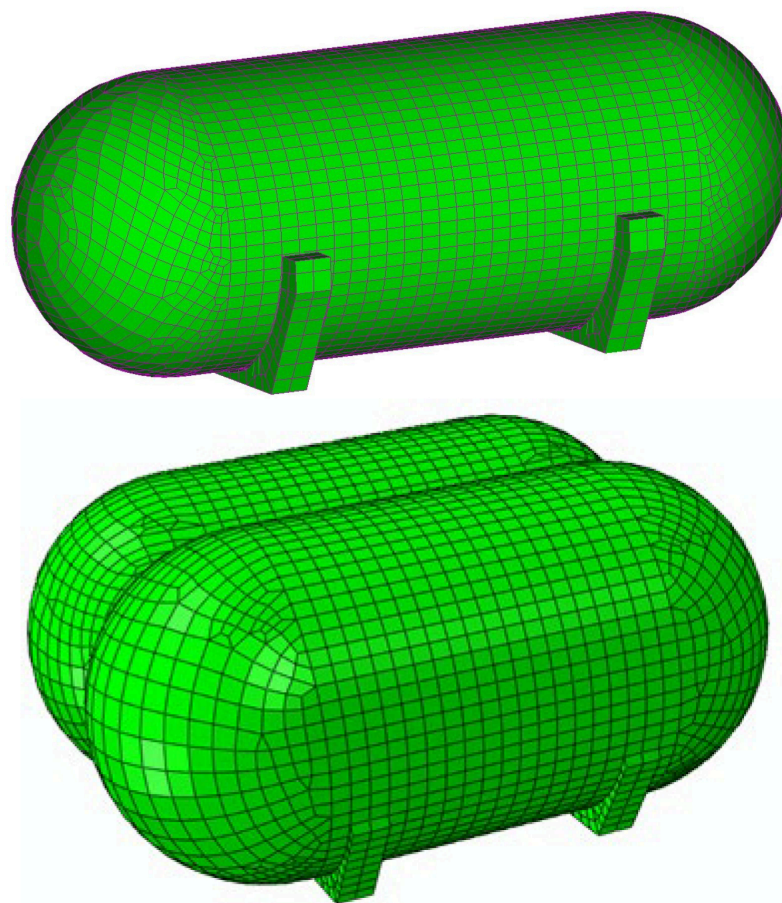
Type C cargo/fuel tanks are also known as “pressure vessels” and are designed and built to meet the requirements of recognized pressure vessel standards or codes such as the ASME BPVC, which are supplemented by additional Class Society requirements and statutory regulations. Since the Type C tank is designed to be independent of the vessel’s hull, it is not essential for maintaining the hull strength or the integrity of the vessel. However, the liquefied gas cargo/fuel tank itself must be designed to sustain all

static and dynamic loads (e.g., weight, wave-induced loads, sloshing loads, etc.) during its service life. In general, there are two categories for Type C tanks applied in liquefied gas cargo vessels or gas fueled ships: foam-insulated single-shell tanks (e.g., cylindrical, bi-lobe, tri-lobe, etc.), as shown in Section 1, Figures 1 and 2, and vacuum-insulated double-shell tanks, as shown in Section 1, Figure 3, respectively. These Guidance Notes address the strength evaluation of these two kinds of Type C tanks and their supporting structures.

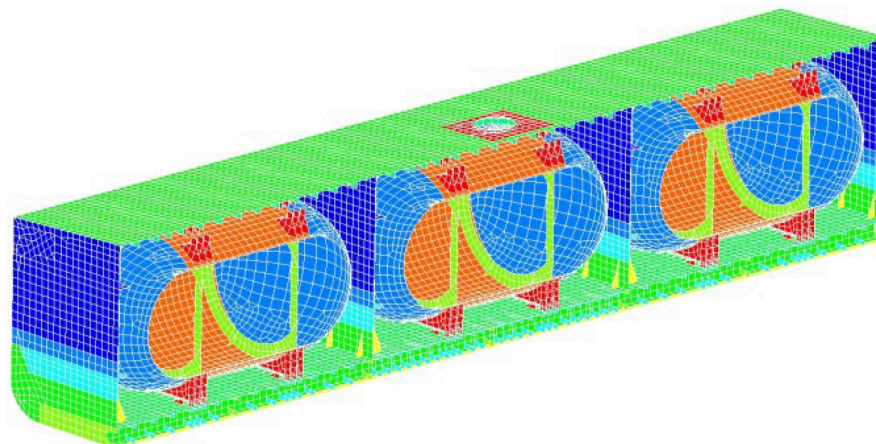
In the *ABS Guide for Building and Classing Liquefied Gas Carriers with Independent Tanks (LGC Guide)*, the procedure for the strength evaluation of hull, tank, and support structures has been developed for gas carriers with independent type gas tanks. However, the *LGC Guide* puts increased emphasis to the hull structure and the independent Type B prismatic tanks in gas carriers. These Guidance Notes provide a procedure for the structural assessment of Type C independent cargo/fuel tank and supporting structures under static and dynamic loads to supplement the *LGC Guide* and Part 5C, Chapter 8 and Part 5C, Chapter 13 of the *Marine Vessel Rules*.

These Guidance Notes define design load cases, which include standard load conditions, accidental load conditions, and test load conditions for yielding and buckling strength assessment, and also design load cases including wave-induced high cycle fatigue load and cargo/fuel loading/unloading induced low cycle fatigue load conditions for fatigue assessment. The finite element (FE) analysis-based direct calculation is required for structural analysis of the tank and support structures in various design load cases. Finally, an analysis procedure is provided for the strength evaluation of the Type C tank and support structures for the yielding, buckling, and fatigue failure modes.

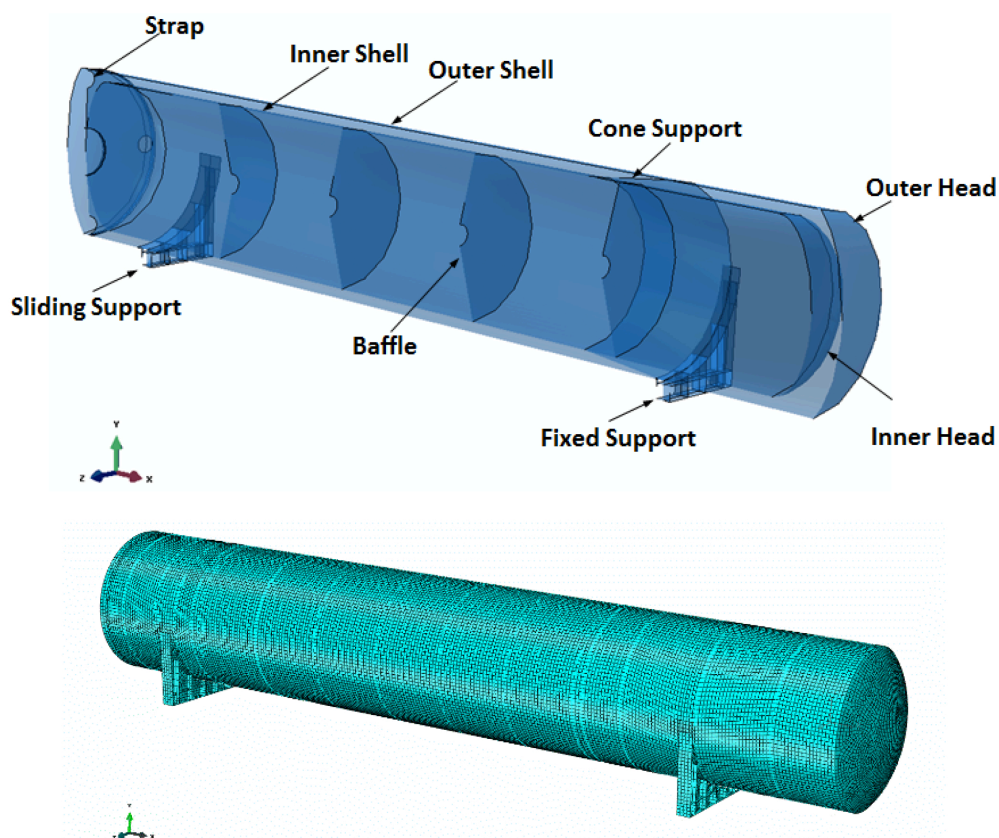
**FIGURE 1**  
**Type C Cylindrical and Bi-Lobe Tanks**



**FIGURE 2 G**  
**lobal FE Model for a Bi-lobe Gas Carrier**



**FIGURE 3**  
**Type C Vacuum-Insulated Fuel Tanks**



## 2 Marine and Offshore Applications

Marine and offshore vessels with independent Type C tanks are applicable to carry a wide range of liquefied gases including LNG, LPG, LEG, Ammonia, Hydrogen, etc.

- For LNG tanks, the LNG temperature is  $\sim -162^{\circ}\text{C}$ . Cryogenic material such as aluminum alloy, stainless steel, or 9% nickel steel is usually selected as the tank material.



- For LPG tanks, the LPG temperature is  $\sim -42^{\circ}$  C. Carbon manganese steel is usually selected as the tank material.
- For LEG tanks, the LEG temperature is  $\sim -89^{\circ}$  C. 5% Nickel steel is usually selected as the tank material.
- For Ammonia tanks, the Ammonia temperature is  $\sim -33^{\circ}$  C. Ammonia can be contained in both LPG and LEG tanks. A special consideration should be taken in stress corrosion cracking in containment and process systems made of carbon-manganese steel or nickel steel caused by ammonia, referring to Part 5C, Chapter 8 of the *Marine Vessel Rules* and *ABS Requirements for Ammonia Fueled Vessels*.
- For Hydrogen tanks, the Hydrogen temperature is  $\sim -253^{\circ}$  C. Cryogenic material such as aluminum alloy, or stainless steel is usually selected as the tank material. A special consideration should be taken to prevent any deterioration owing to hydrogen embrittlement, referring to *ABS Sustainability Whitepaper, Hydrogen as Marine Fuel*.

As a reference, the mechanical properties for several materials are provided in Appendix 2.

Please note that this document is intended for metallic Type C tanks and that composite Type C tanks will be specially considered for review and approval.

### 3 Abbreviations

AWS	American Welding Society
BOR	Boil-Off Rate
BPVC	ASME Boiler and Pressure Vessel Code
CFD	Computational Fluid Dynamics
CSWD	Critical Sloshing Wave Domain
DOF	Degrees of Freedom
ECA	Emission Control Area
FE	Finite Element
IGC	International Code of the Construction and Equipment of Ships Carrying Liquefied Gases in Bulk Code
IGF	The International Code of Safety for Ships using Gases or other Low-flashpoint Fuels
LEG	Liquefied Ethane Gas
LGC	Liquefied Gas Carrier
LNG	Liquefied Natural Gas
LPG	Liquefied Petroleum Gas
MARVS	Maximum Allowable Relief Valve Setting
MGO	Marine Gas Oil
NG	Natural Gas
PRVs	Pressure Relief Valves

### 4 Overview of Strength Evaluation of Independent Type C Tanks

Section 1, Figure 4 presents a flowchart denoting the structural strength evaluation of the independent Type C tank and supporting structures under various design load cases. Per the *LGC Guide*, for the strength assessment against yielding and buckling failure modes, the dynamic load criteria represent the long-term extreme values for the North Atlantic corresponding to a probability of exceedance of  $10^{-8}$ . For strength assessment against fatigue failure mode, the dynamic load criteria represent characteristic values for the

North Atlantic, corresponding to a probability of exceedance of  $10^{-4}$ . In the current Guidance Notes, both static and dynamic loads need to be considered for the strength evaluation of tank and supporting structures in a Type C containment system.

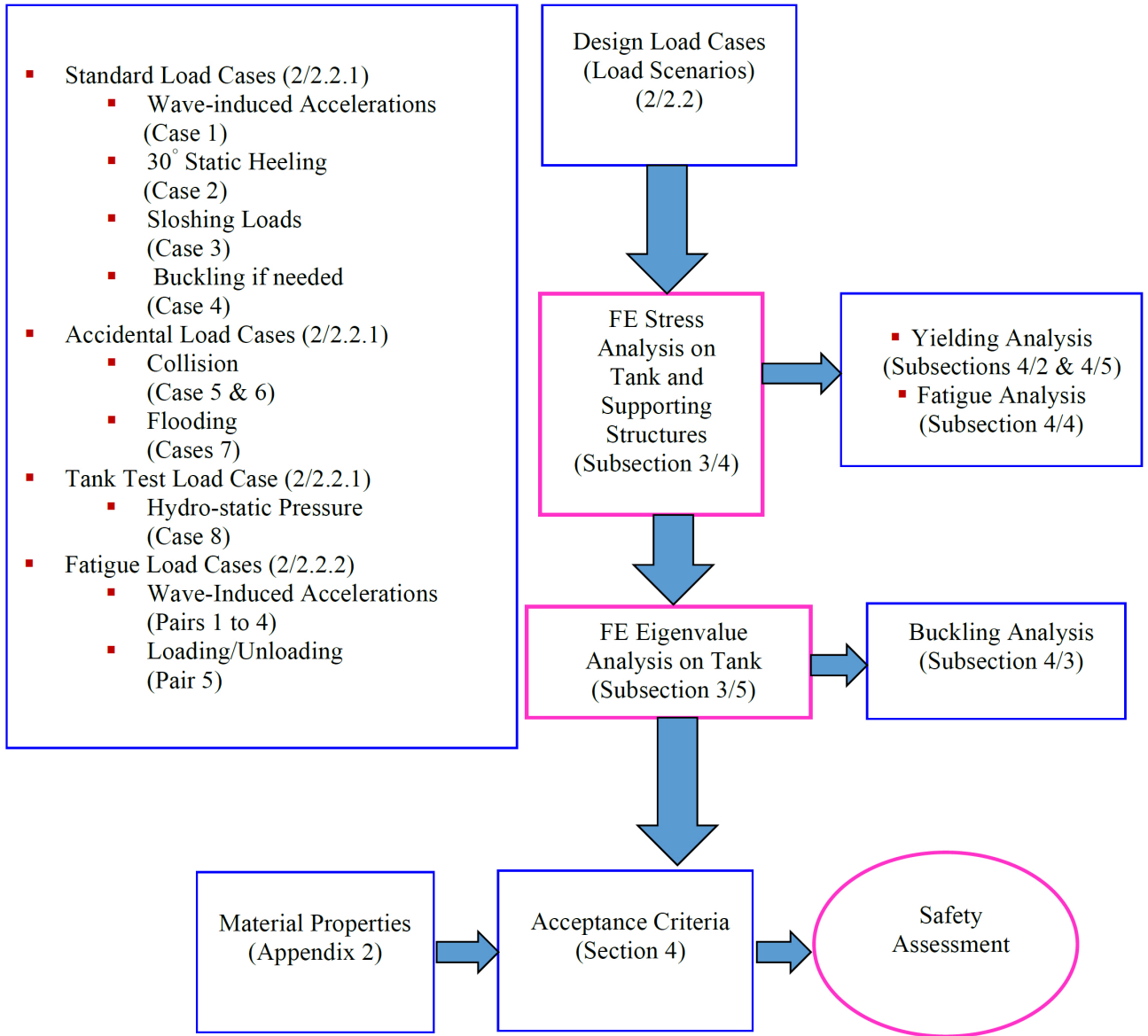
To assess the yielding and buckling strength of tank and supporting structures, design loads should include the self-weight of the tank system, thermal loads due to temperature gradient, vapor pressure and external pressure, static loads at 30° heeling, liquid hydrostatic pressure, hydrodynamic pressure due to accelerations, sloshing loads, etc., referring to Part 5C, Chapter 8 and Part 5C, Chapter 13 of the *Marine Vessel Rules*. Design load cases are categorized into standard load cases, accidental load cases, and test load case. In Standard Load Cases, dynamic loads are mainly caused by wave-induced accelerations including longitudinal, transverse, and vertical accelerations, respectively.

- Dynamic loads together with gravity are used to generate Load Case 1.
- A 30° static heeling condition is used for Load Case 2.
- Dynamic load caused by sloshing loads due to the vessel motion is used to generate Load Case 3.
- A special load condition related to buckling is used to generate Load Case 4.
- Additionally, accidental load cases are considered including forward/afterward collisions with other objects for Load Cases 5 & 6 and water submerged flooding for Load Case 7.
- The tank test condition, considering hydrostatic testing pressure, is used for Load Case 8.

To assess the critical details of the tank and supporting structures in some special cases, the accumulative fatigue damage ratio may be calculated as the Type C tank is operating in full load and ballast load conditions as well as a cargo/fuel loading/unloading condition. Fatigue load cases include standard load cases for Load Pairs 1 through 4 with wave induced high cycle fatigue, and cargo/fuel loading/unloading induced low cycle fatigue for Load Pair 5, referring to the *LGC Guide*. Fatigue assessment is usually required for welding and connection areas in tank and supporting structures in a Type C tank under cyclic loads.

For all these design load cases, stress analysis using the finite element (FE) method should be performed to determine the stress distributions of tank and supporting structures. If fatigue assessment is needed, the stress analysis results are employed for calculating the reference stress range corresponding to each individual load pair at critical locations such as welding and connection areas in the tank and supporting structures. Meanwhile, FE eigenvalue analyses are conducted for the buckling evaluations of the tank structure under the external pressure and the water flooding pressure with pre-loading external pressure, respectively. The mechanical properties of materials for each structural component used in structural analyses should include, but not limited to, elastic Young's modulus, Poisson's ratio, yielding strength, ultimate strength, fatigue S-N curve, etc. Finally, the strength of tank and supporting structures is assessed for an independent Type C cargo/fuel tank with a certain level of safety margin following the *LGC Guide* and Part 5C, Chapter 8 and Part 5C, Chapter 13 of the *Marine Vessel Rules*.

**FIGURE 4**  
**Flowchart of Structural Integrity Assessment**



## SECTION 2

### Loads and Design Load Cases

**Note:** Text in *italics* comes from the International Code for the Construction and Equipment of Ships Carrying Liquefied Gases in Bulk (IGC Code) and the International Code of Safety for Ships using Gases or other Low-flashpoint Fuels (IGF Code).

#### 1 General

As required by Part 5C, Chapter 8 and Part 5C, Chapter 13 of the *Marine Vessel Rules*, the strength of independent Type C cargo/fuel tanks and their supporting structures should be evaluated against yielding, buckling, and fatigue. For each failure mode, all standard and accidental load cases as well as the test load case should be considered and applied to the tank and supporting structures.

In structural analysis, design loads need to be determined for the design of a Type C cargo/fuel tank structure and its supports. Typical loads for the design of a cryogenic pressure vessel include internal pressure loads due to tank pressurization, thermal loads due to temperature variations during the loading/unloading of liquid cargo/fuel or initial cooling down period, deadweight of the tank and its contents, and reaction loads due to supports and attachments. In addition, the unique loads associated with operating in a marine environment, such as dynamic loads due to ship motions and sloshing loads, also need to be considered.

When the Type C tank is designed as a vacuum-insulated tank, the major components of this tank system include an insulated inner tank, evacuated outer jacket, inside supports between two shells, and outside supports (saddles). The function of the outer jacket is mainly to maintain the vacuum as thermal insulation and to support the inner tank. The buckling strength of the outer jacket should be evaluated under the vacuum pressure. The evaluation of inside supports between inner and outer vessels should be performed considering the load transfer due to the relative thermal contraction between the inner tank and the outer jacket. Also, the vacuum pressure between the two vessels should be considered in the design pressure as well. Thus, the yielding, buckling, and fatigue evaluations should be considered for Type C vacuum-insulated tank.

Based on the most severe load condition which the vessel may experience during a service life and cyclic load condition, tank and supporting structures should be evaluated against yielding, buckling, and fatigue failures. Design load cases can be categorized as follows:

- Standard load cases (LC1 - LC4)
- Accidental load cases (LC5 - LC7)
- Tank test load case (LC8)
- Fatigue (Load Pairs 1 - 4 & 5)

During the service life, design load cases for the tank design should consider the appropriate combinations of different loads, such as internal pressure, external pressure, and sloshing loads. The internal pressure

includes hydrostatic and hydrodynamic pressures, which are caused by both liquid acceleration and gravity in fully loaded condition. The design life of Type C liquefied gas tanks should not be less than the design life of the vessel.

## 2 Loads and Design Load Cases

Referring to the requirements in Part 5C, Chapter 8 and Part 5C, Chapter 13 of the *Marine Vessel Rules*, the design loads of cargo/fuel containment systems should take into account the proper combinations of the following loads:

- Internal pressure
- External pressure
- Dynamic loads due to ship motion in all loading conditions
- Thermal loads
- Sloshing loads
- Loads corresponding to ship deflections
- Tank and cargo weight with the corresponding reaction in way of supports
- Insulation weight
- Loads in way of towers and other attachments
- Test loads
- Wind impact, wave impacts and green sea effect for fuel tanks installed on open deck.

The internal pressure is a design vapor pressure inside the tank. If it is a vacuum-insulated tank, the external pressure is the pressure on the outer tank caused by evacuation between the outer tank and inner tank. In this Section, design load cases including four standard load cases, three accidental load cases, and one test load case are defined considering all applicable loads in the above for the strength and fatigue assessment of independent Type C cargo/fuel tank and supporting structures.

### 2.1 Static and Dynamic Loads

In general, the tank and supporting structure is subjected to static and dynamic loads as well as other loads during service. Static loads may include:

- i)* Self-weight of tank system including tank shell, insulation, as well as domes and piping
- ii)* Cargo/fuel weight
- iii)* Internal overpressure loads due to inner tank pressurization
- iv)* External overpressure loads due to the pressure difference between the minimum internal pressure and the maximum external pressure
- v)* Static loads due to 30° heeling

Dynamic loads may include:

- i)* Dynamic loads due to ship motion
- ii)* Sloshing loads

Accidental loads are:

- i)* Collision loads
- ii)* Flooding loads

Other loads may include:

- i) Thermal loads due to temperature variations during the loading/unloading of liquid cargo/fuel or initial cooling down period.
- ii) Interaction loads due to hull deflection
- iii) wind impact, wave impacts and green sea effect for fuel tanks installed on open deck.

### 2.1.1 Design Vapor Pressure

The design basis for an independent Type C tank is based on pressure vessel criteria modified to include fracture mechanics and crack propagation criteria. Referring to Part 5C, Chapter 8 and Part 5C, Chapter 13 of the *Marine Vessel Rules*, the design vapor pressure for a cargo/fuel tank should not be less than:

$$P_0 = 0.2 + AC(\rho_r)^{1.5} \quad (\text{MPa})$$

where:

$$A = 0.00185 \left( \frac{\sigma_m}{\Delta \sigma_A} \right)^2$$

with

$\sigma_m$  = design primary membrane stress\*;

$\Delta \sigma_A$  = allowable dynamic membrane stress (double amplitude at probability level  $Q = 10^{-8}$ ). and equal to:

55 MPa for ferritic-perlitic, martensitic and austenitic steel;

25 MPa for aluminum alloy (5083-O);

When the specified design life of a tank is greater than  $10^8$  wave encounters,  $\Delta \sigma_A$  should be modified to give equivalent crack propagation corresponding to the design life.

$C$  = a characteristic tank dimension to be taken as the greatest of the following:

$h$ ,  $0.75b$  or  $0.45\ell$ ,

with

$h$  = height of tank (dimension in ship's vertical direction) (m)

$b$  = width of tank (dimension in ship's transverse direction) (m)

$\ell$  = length of tank (dimension in ship's longitudinal direction) (m)

$\rho_r$  = relative density of the cargo ( $\rho_r = 1$  for fresh water) at the design temperature

\*maximum allowable stress can be taken as design primary membrane stress as applicable.

Referring to the requirements in Part 5C, Chapter 8 and Part 5C, Chapter 13 of the *Marine Vessel Rules*, for a Type C fuel tank, natural gas in a liquid state may be stored with a maximum allowable relief valve setting (MARVS) of up to 1.0 MPa to avoid operations under the high pressure.

### 2.1.2 External Pressure

Design external pressure loads are based on the difference between the minimum internal pressure and the maximum external pressure to which any portion of the tank may be simultaneously

subjected. The design external pressure  $P_e$ , used for verifying the buckling of the pressure vessels, should not be less than that given by:

$$P_e = P_1 + P_2 + P_3 + P_4 \quad (\text{MPa})$$

where:

- $P_1$  = setting value of vacuum relief valves. For vessels not fitted with vacuum relief valves,  $P_1$  should be specially considered, but not, in general, taken as less than 0.025 MPa. See 5C-8-8/3.1.2 of the *Marine Vessel Rules*.
- $P_2$  = set pressure of the pressure relief valves (PRVs) for completely closed spaces containing pressure vessels or parts of pressure vessels; elsewhere  $P_2 = 0$ .
- $P_3$  = compressive actions in or on the shell due to the weight and contraction of thermal insulation, weight of shell including corrosion allowance and other miscellaneous external pressure loads to which the pressure vessel may be subjected. These include, but are not limited to, weight of domes, weight of towers and piping, effect of product in the partially filled condition, accelerations and hull deflection. In addition, the local effect of external or internal pressures or both should be taken into account.
- $P_4$  = external pressure due to head of water for pressure vessels or part of pressure vessels on exposed decks; elsewhere  $P_4 = 0$ .

If a fuel tank is installed on open deck, wind impact, wave impacts and green sea effect should be considered. However, in most cases, these loads can be ignored in the design. Where the green sea loads are considered to be significant, the calculation of expected loads can refer to Part 3, 3-2-11 of the *Marine Vessel Rules*.

### 2.1.3 Static Loads due to 30° Heeling

While operating at sea or while in port, the vessel may statically heel at an angle, either due to a loading condition, an accident or an unforeseen event. Under these circumstances, the deadweight of the tank and its contents would no longer act in the direction of vertical axis downwards in the ship fixed coordinate system but would act at an angle with respect to the vertical axis. Therefore, the tank structure and supports should be designed to withstand the loads associated with this static heeling of the tank and the vessel. The most unfavorable static heel angle within the range of 0° to 30° should be considered as static loads due to the static heeling condition of a vessel.

### 2.1.4 Loads due to Hull Deflection

In general, there are saddle supports at both ends of a Type C tank. One end is fully clamped while the other end acts as a roller to allow sliding along the longitudinal direction of the tank. This design compensates for the contraction and expansion of the tank due to its temperature changes during operation. Therefore, it is recommended that tanks be supported at only two locations to avoid absorbing ship hull deflections. Whenever practicable, the designer should consider installing the tank foundations in line with the under-deck framing of the vessel. This will minimize the effect of ship structure deflections on the gas tank and will satisfactorily transfer heavy loads. In such cases, the effect of hull deflection is usually insignificant and may be neglected.

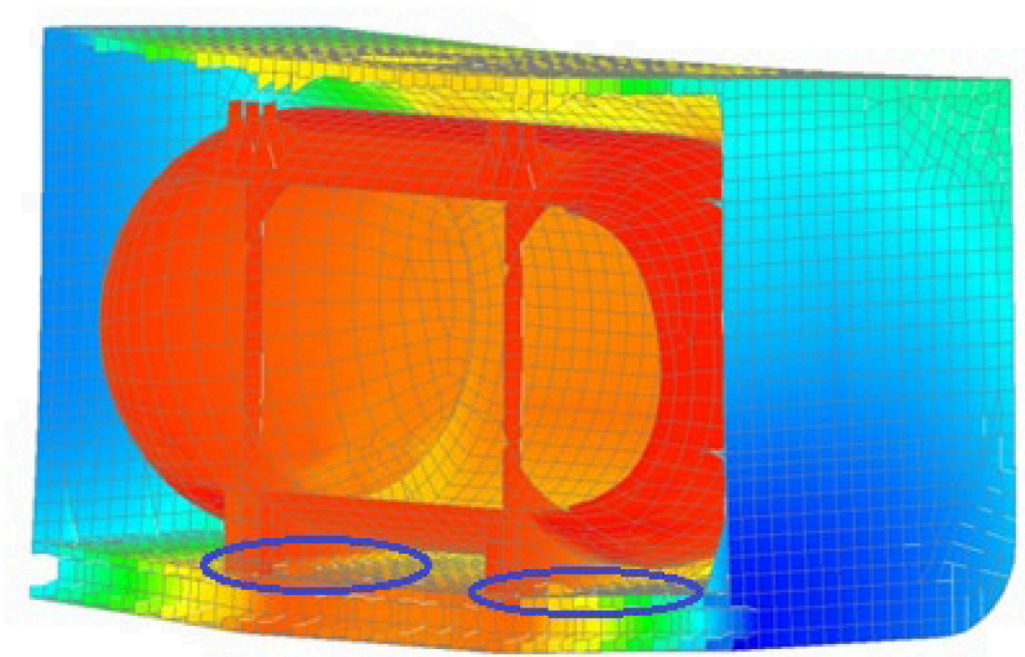
When three or more supports are installed on the tanks, hogging or sagging of the ship structure in-way of the tank due to ship hull girder loads could lead to additional reaction loads acting on the tank structure and its supports. In such cases, the effects of vertical deflections imposed on the tank through the tank-hull girder interaction would also need to be considered for all loading conditions. In a gas fueled ship, all fuel tanks are usually designed to be supported at only two

locations to minimize the effect of ship hull deflections. Since the length of the fuel tank is relatively small compared to the vessel length, the hull deflection effect is negligible.

In determining these additional loads, the designer first needs to consider the maximum anticipated deflections of the ship structure in way of the gas tank under still-water conditions and under hogging and sagging wave conditions. Thereafter, the additional loads on the tank structure and its supports can be calculated using the first principles analysis or finite element analysis.

The general procedure using FE analysis is as follows. The global FE analysis of the hull structure with gas tanks and their supports is performed, shown in Section 2, Figure 1. The displacements and rotations at the interface between saddle supports and hull structure are calculated under critical loading conditions. These displacements and rotations at the interface from global FE analysis are applied to the detailed local FE model as boundary conditions for conducting tank and support analyses under static and dynamic loads. Additionally, if hull interaction loads need to be considered according to the tank and vessel size, fatigue evaluation may be required for tank and supporting structures.

**FIGURE 1**  
**Deflection of Ship Structure from Global FE Modeling**



### 2.1.5 Dynamic Loads due to Ship Motion

Dynamic loads, such as the hydrodynamic pressure on the tank, are caused by accelerations due to the vessel motion. In the Part 5C, Chapter 8 and Part 5C, Chapter 13 of the *Marine Vessel Rules*, dynamic acceleration calculations can be performed using empirical formulae. Then, the internal pressure inside the tank can be determined.

#### 2.1.5(a) Dynamic Acceleration Calculation

An independent cargo/fuel tank installed on a vessel operating at sea inevitably experiences dynamic loads due to the ship motion in seawater. Dynamic loads can be determined by conducting a seakeeping analysis of the vessel or by measuring the accelerations using accelerometers on the full-scale vessel or during model testing. Determination of dynamic loads is usually necessary to consider all anticipated motions the vessel may experience, corresponding to



not less than  $10^8$  wave encounters during the design service life. This includes the motions in all six degrees of freedom including surge, sway, heave, roll, pitch, and yaw. North Atlantic environmental conditions and the relevant long-term sea state scatter diagrams for unrestricted navigation are typically used to determine dynamic loads. The resultant dynamic loads that would be applied on the tank would be in the form of three mutually perpendicular acceleration components that would be considered as acting at the center of gravity of the tank. These include the following components:

- i) Vertical acceleration (predominantly due to heave and pitch)
- ii) Transverse acceleration (predominantly due to sway, yaw and roll)
- iii) Longitudinal acceleration (predominantly due to surge and pitch)

Methods to predict accelerations due to ship motion should be proposed and approved by the Administration or recognized organization acting on its behalf. In general, ship motion analysis can be performed to determine all acceleration components.

In Part 5C, Chapter 8 of the *Marine Vessel Rules*, the following formulae are also given as guidance for the components of acceleration due to ship's motions corresponding to a probability level of  $10^{-8}$  in the North Atlantic and apply to vessels with a length exceeding 50 m and at or near their service speed:

*Vertical acceleration:*

$$a_z = \pm a_0 \sqrt{1 + \left(5.3 - \frac{45}{L_0}\right)^2 \left(\frac{x}{L_0} + 0.05\right)^2 \left(\frac{0.6}{C_B}\right)^{1.5} + \left(\frac{0.6yK^{1.5}}{B}\right)^2}$$

*Transverse acceleration:*

$$a_y = \pm a_0 \sqrt{0.6 + 2.5 \left(\frac{x}{L_0} + 0.05\right)^2 + K \left(1 + 0.6K \frac{z}{B}\right)^2}$$

*Longitudinal acceleration:*

$$a_x = \pm a_0 \sqrt{0.06 + A^2 - 0.25A}$$

with

$$A = \left(0.7 - \frac{L_0}{1200} + 5 \frac{z}{L_0}\right) \left(\frac{0.6}{C_B}\right)$$

where

$$a_0 = k_p \left(0.2 \frac{v}{\sqrt{L_0}} + \frac{34 - \left(\frac{600}{L_0}\right)}{L_0}\right)$$

- $k_p$  = load factor for adjusting the probability of exceedance
- = 1.0 for yielding and buckling strength assessment
- = 0.5 for fatigue strength assessment

$L_0$  = length of the ship for determination of scantlings as defined in recognized standards (m)

$C_B$  = block coefficient

$B$  = greatest molded breadth of the ship (m)

$x$	=	longitudinal distance (m) from amidships to the center of gravity of the tank with contents; $x$ is positive forward of amidships, negative aft of amidships
$y$	=	transverse distance (m) from centerline to the center of gravity of the tank with contents;
$z$	=	vertical distance (m) from the vessel's actual waterline to the center of gravity of tank with contents; $z$ is positive above and negative below the waterline
$K$	=	1 in general. For particular loading conditions and hull forms, determination of $K$ according to the following formula may be necessary: $K = 13GM/B$ , where $K \geq 1$ and $GM$ = metacentric height (m)
$V$	=	service speed (knots);
	=	10 knots for yielding and buckling strength assessment
	=	75% of the design speed for fatigue strength assessment
$a_x, a_y, a_z$	=	maximum dimensionless accelerations (i.e. relative to the acceleration of gravity) in the respective directions. They are considered as acting separately for calculation purposes, and $a_z$ does not include the component due to the static weight, $a_y$ includes the component due to the static weight in the transverse direction due to rolling and $a_x$ includes the component due to the static weight in the longitudinal direction due to pitching. The accelerations derived from the above formulae are applicable only to ships at or near their service speed, not while at anchor or otherwise near stationary in exposed locations.

Note that the above formulae for acceleration components are applicable for gas carriers. For other types of vessels, the acceleration formulae may refer to corresponding Chapters in the *Marine Vessel Rules* to calculate vessel accelerations, as applicable.

#### 2.1.5(b) Internal Pressure Calculation

To determine the inertial forces and added pressure heads for a fully filled cargo tank, the dominating ship motion parameters induced by waves are calculated. The internal pressure  $p_{eq}$  resulting from the design vapor pressure  $p_o$  or  $p_h$  plus the maximum associated dynamic liquid pressure  $p_{gd}$ , but not including effects of liquid sloshing loads, which is addressed in 2/2.1.6.  $p_{eq}$  should be the greater of  $p_{eq1}$  and  $p_{eq2}$  calculated as follows:

$$p_{eq1} = p_o + (p_{gd})_{\max} \quad (\text{MPa})$$

$$p_{eq2} = p_h + (p_{gd \text{ site}})_{\max} \quad (\text{MPa})$$

where

$(p_{gd})_{\max}$  = the associated liquid pressure determined using the maximum design accelerations.

$(p_{gd \text{ site}})_{\max}$  = is the associated liquid pressure determined using site specific accelerations.

*The internal liquid pressures are those created by the resulting acceleration of the center of gravity of the cargo due to the motions of the ship. The value of internal liquid pressure  $P_{gd}$  resulting from combined effects of gravity and dynamic accelerations is calculated as follows:*

$$p_{gd} = a_{\beta} Z_{\beta} \frac{\rho}{1.02 \times 10^5} \quad (\text{MPa})$$

where

$a_{\beta}$  = dimensionless acceleration (i.e., relative to the acceleration of gravity), resulting from gravitational and dynamic loads, in an arbitrary direction  $\beta$  (see Section 2, Figure 2)

$Z_{\beta}$  = largest liquid height (m) above the point where the pressure is determined, measured from the tank shell in the  $\beta$  direction (see Section 2, Figure 3)

*Tank domes considered to be part of the accepted total tank volume should be taken into account when determining  $Z_{\beta}$  unless the total volume of tank domes  $V_{dom}$  does not exceed the following value:*

$$V_{dom} = V_{tank} \left( \frac{100 - FL}{FL} \right)$$

where

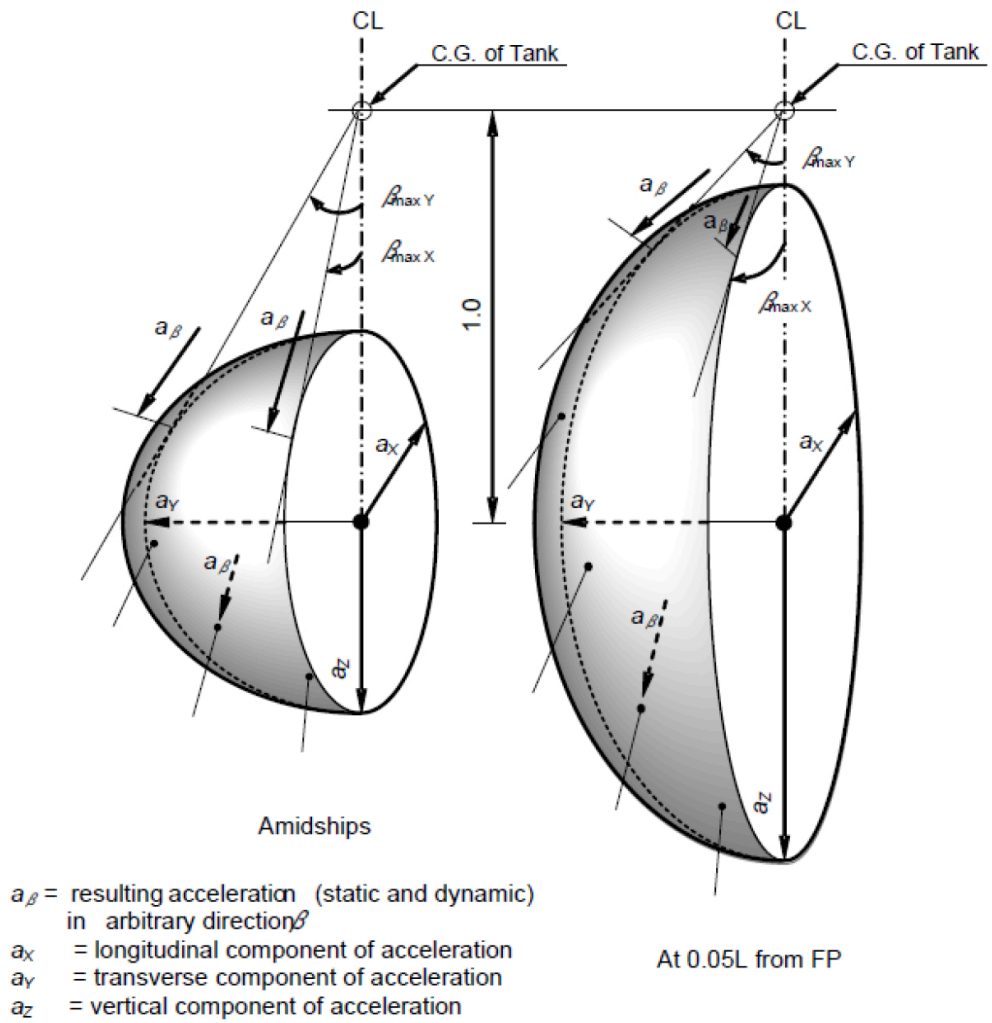
$V_{tank}$  = tank volume without any domes

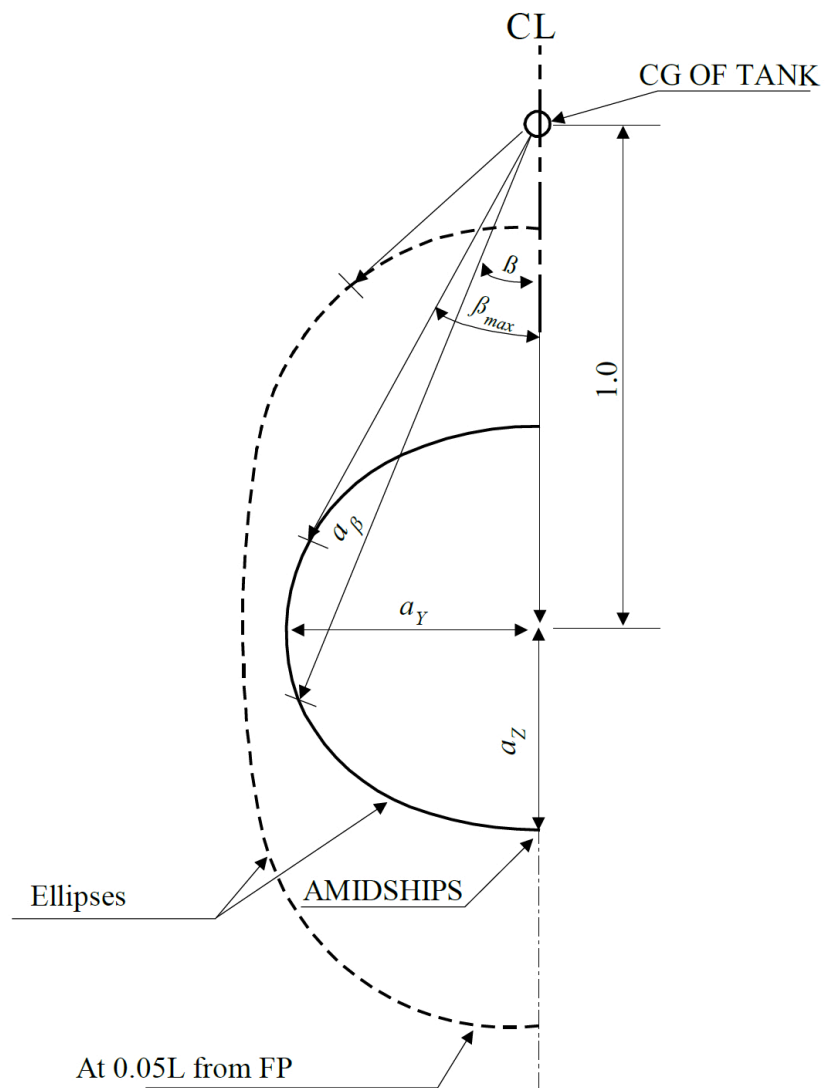
$FL_{Rules}$  = filling limit according to Section 5C-8-15 of the *Marine Vessel Rules*

$\rho$  = maximum cargo/fuel density (kg/m<sup>3</sup>) at the design temperature

The direction which gives the maximum value  $(p_{gd})_{max}$  of  $p_{gd}$  is considered for the scantling requirements of plating and stiffeners of cargo tank boundaries. Where acceleration components in three directions need to be considered, an ellipsoid is used instead of the ellipse in Section 2, Figure 2. The above formula applies only to full tanks.

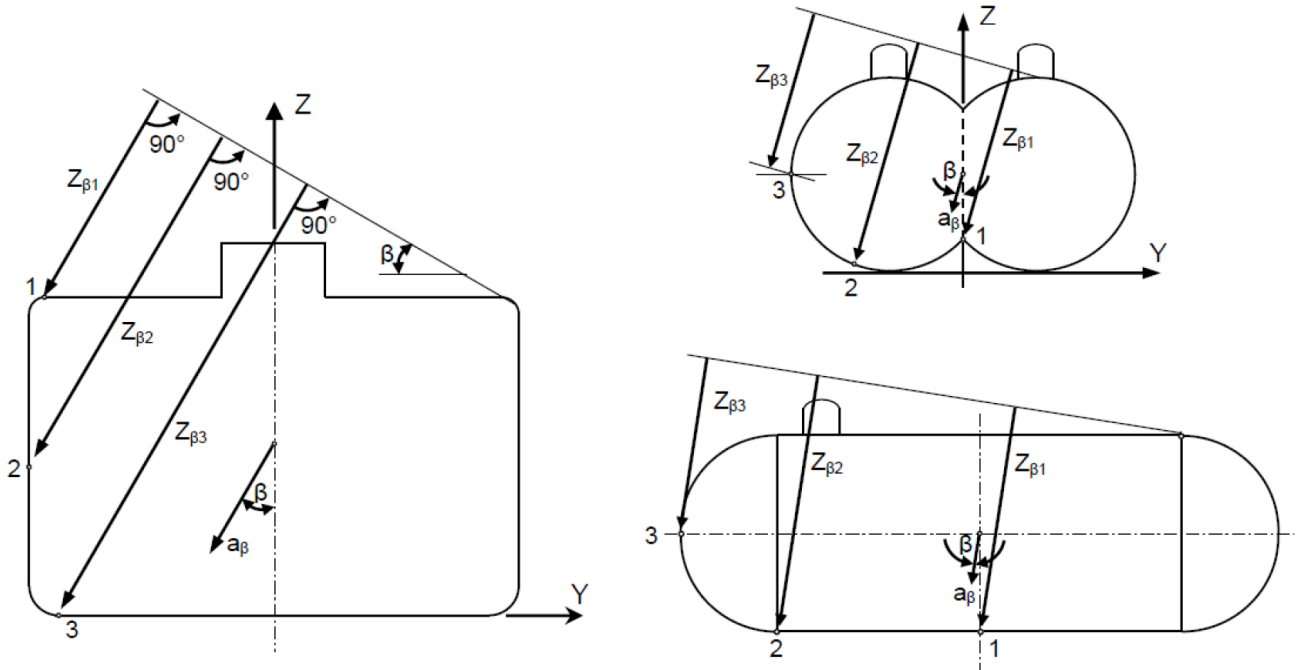
**FIGURE 2**  
**Acceleration Ellipsoid and Ellipse**





$a_{\beta}$  = resulting acceleration (static and dynamic) in arbitrary direction  $\beta$   
 $a_Y$  = transverse component of acceleration  
 $a_Z$  = vertical component of acceleration

**FIGURE 3**  
**Determination of Internal Pressure Heads**



For the acceleration ellipse in Y-Z plane, the resultant acceleration (static and dynamic) along arbitrary angle  $\beta_{YZ}$  can be described by:

$$a_{\beta_{YZ}} = \frac{a_Y^2 \cos \beta_{YZ} + a_Y a_Z \sqrt{a_Y^2 \cos^2 \beta_{YZ} + a_Z^2 \sin^2 \beta_{YZ} - \sin^2 \beta_{YZ}}}{a_Y^2 \cos^2 \beta_{YZ} + a_Z^2 \sin^2 \beta_{YZ}}$$

and

$$\beta_{YZ, \max} = \arctan\left(\frac{a_Y}{\sqrt{1 - a_Z^2}}\right)$$

Thus, dynamic liquid pressure:  $p_{gd, \beta_{YZ}} = a_{\beta_{YZ}} Z \rho / (1.02 \times 10^5)$  (MPa), the maximum value of dynamic liquid pressure,  $(p_{gd, \beta_{YZ}})_{\max}$  can be determined by changing the angle  $\beta_{YZ}$  with an increment in the range of  $(0, \beta_{YZ, \max})$ .

In the same way, for the acceleration ellipse in X-Z plane, the resultant acceleration (static and dynamic) along arbitrary angle  $\beta_{XZ}$  can be described by

$$a_{\beta_{XZ}} = \frac{a_X^2 \cos \beta_{XZ} + a_X a_Z \sqrt{a_X^2 \cos^2 \beta_{XZ} + a_Z^2 \sin^2 \beta_{XZ} - \sin^2 \beta_{XZ}}}{a_X^2 \cos^2 \beta_{XZ} + a_Z^2 \sin^2 \beta_{XZ}}$$

and

$$\beta_{XZ, \max} = \arctan\left(\frac{a_X}{\sqrt{1 - a_Z^2}}\right)$$

Thus, dynamic liquid pressure:  $p_{gd, \beta_{XZ}} = a_{\beta_{XZ}} Z_{\beta_{XZ}} \rho / (1.02 \times 10^5)$  (MPa), the maximum value of dynamic liquid pressure,  $(p_{gd, \beta_{XZ}})_{max}$ , can be determined by changing the angle  $\beta_{YZ}$  with an increment in the range of  $(0, \beta_{XZ, max})$ .

The design dynamic liquid pressure:

$$p = \max\{p_0 + (p_{gd, \beta_{YZ}})_{max} p_0 + (p_{gd, \beta_{XZ}})_{max}\}$$

For the three-dimensional acceleration ellipsoid, the resultant acceleration (static and dynamic) along arbitrary angle of  $\beta_{YZ}$  and  $\beta_{XZ}$  can be expressed by:

$$a_{\beta_{YZ}, \beta_{XZ}} = \frac{1 + a_Z \sqrt{1 + (a_Z^2 - 1) \left( \frac{\tan^2 \beta_{YZ}}{a_X^2} + \frac{\tan^2 \beta_{XZ}}{a_Y^2} \right)}}{1 + a_Z^2 \left( \frac{\tan^2 \beta_{YZ}}{a_X^2} + \frac{\tan^2 \beta_{XZ}}{a_Y^2} \right)} \sqrt{1 + \tan^2 \beta_{YZ} + \tan^2 \beta_{XZ}}$$

where

$$\frac{\tan^2 \beta_{YZ}}{a_X^2} + \frac{\tan^2 \beta_{XZ}}{a_Y^2} \leq \frac{1}{1 - a_Z^2}$$

and

$$\beta_{YZ, max} = \arctan\left(\frac{a_Y}{\sqrt{1 - a_Z^2}}\right) \quad \text{and} \quad \beta_{XZ, max} = \arctan\left(\frac{a_X}{\sqrt{1 - a_Z^2}}\right)$$

Therefore, dynamic liquid pressure:  $p_{gd} = a_{\beta_{YZ}, \beta_{XZ}} Z_{\beta_{YZ}, \beta_{XZ}} \rho / (1.02 \times 10^5)$  (MPa), the maximum value of dynamic liquid pressure,  $(p_{gd})_{max}$ , can be determined by either directly differentiating the above equation with respect to the angle or trying different angles  $\beta_{YZ}$  and  $\beta_{XZ}$  with an increment in the range of  $(0, \beta_{YZ, max})$  and  $(0, \beta_{XZ, max})$ .

In FE analysis, the resultant acceleration with its magnitude and direction, which is corresponding to the  $(p_{gd})_{max}$ , can be employed to determine the internal pressure inside the tank.

An example for determining the pressure heads and the maximum dynamic pressure of a bi-lobe tank with a diameter of  $D$  designed with a non-watertight central bulkhead between two lobes is given as follows:

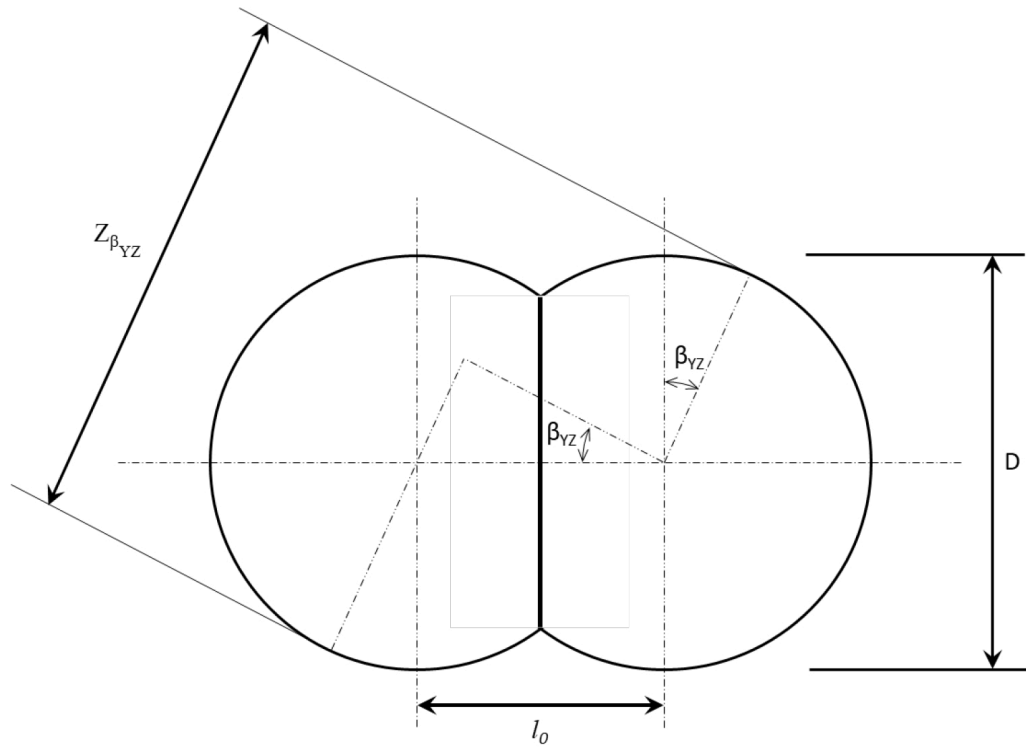
The liquid height in YZ-plane based on acceleration ellipse can be determined by:

$$Z_{\beta_{YZ}} = l_0 \times \sin \beta_{YZ} + D$$

where  $l_0$  is the center distance of a bi-lobe tank ( $l_0 = 0$  in case of a cylindrical tank), and  $D$  is the inner diameter of the tank, as shown in Section 2, Figure 4.

In a typical design of a bi-lobe tank, the central bulkhead is not watertight because an interconnecting pipe is fitted through the central bulkhead to keep the top space pressure balanced. In this case, if the central bulkhead between two lobes in the tank is considered as watertight, the liquid height in the YZ-plane can be expressed by  $Z_{\beta_{YZ}} = D$ . However, for conservative design consideration, a higher liquid height can be considered in the strength evaluation.

**FIGURE 4**  
**YZ Plane for a Bi-Lobe Tank**



The liquid height in the XZ-plane based on acceleration ellipse can be determined by:

$$Z_{\beta_{XZ}} = L_0 \times \sin\beta_{XZ} + D$$

where  $L_0$  is the longitudinal length of cylindrical part, as shown in Section 2, Figure 5.

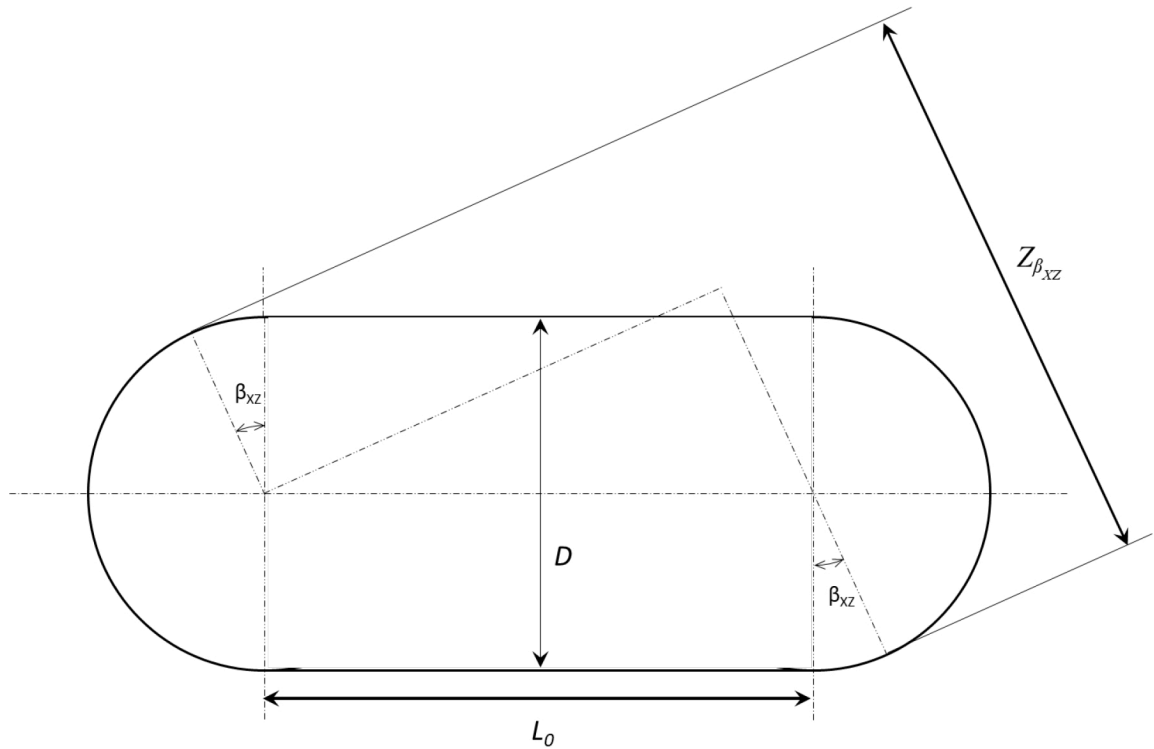
Based on a three-dimensional acceleration ellipsoid, the liquid height can be determined by:

$$Z_{\beta_{YZ}, \beta_{XZ}} = l_0 \times \sin\beta_{YZ} \times \cos\beta_{XZ} + L_0 \times \sin\beta_{XZ} + D$$

Thus, dynamic liquid pressure  $p_{gd} = a_{\beta_{YZ}, \beta_{XZ}} Z_{\beta_{YZ}, \beta_{XZ}} \rho / (1.02 \times 10^5)$  (MPa), the maximum value of dynamic liquid pressure,  $(p_{gd})_{max}$ , can be determined by either directly differentiating the above equation with respect to the angle or the interactively processing different angles  $\beta_{YZ}$  and  $\beta_{XZ}$  with an increment using YZ-plane and XZ-plane formulae.



**FIGURE 5**  
**XZ Plane for a Bi-Lobe Tank**



### 2.1.6 Sloshing Loads

Whenever a partially filled tank experiences motion at sea, the fluid within the tank also experiences motion causing it to slam against internal splash baffles and the tank wall, thus imparting impact loads on them. The magnitudes of these impact loads depend on factors such as the tank geometry and dimensions, tank filling levels, the fluid density, and the tank motion in the operating sea state. In general, regarding the sloshing evaluation of Type C tank, the possibility of resonance at all filling levels should be checked to determine the need for a swash bulkhead.

The natural period of the fluid motion may be approximated by the following equations:

$$T_x = (\ell)^{1/2} / k \text{ seconds in the longitudinal direction}$$

$$T_y = (b_f)^{1/2} / k \text{ seconds in the transverse direction}$$

where

$$\ell = \text{length of the tank, as defined in Figure 6, in m}$$

$$b_f = \text{breadth of the liquid surface at } d_o, \text{ as defined in Section 2, Figure 6, in m}$$

$$k = [(\tanh H_1)(4\pi/g)]^{1/2}$$

$$H_1 = \pi d_o/\ell \text{ or } \pi d_o/b_f$$

$$d_o = \text{filling depth, as defined in Section 2, Figure 6, in m}$$

$$g = \text{acceleration of gravity} = 9.8 \text{ m/sec}^2$$

The natural periods given below for pitch and roll of the vessel,  $T_p$  and  $T_r$ , using the actual draft and GM, if available, may be used for this purpose. In absence of this data, the vessel's draft may be taken as  $2/3d_f$ , where  $d_f$  is the scantling draft.

The pitch natural period:

$$T_p = 3.5\sqrt{C_b d_i} \text{ seconds}$$

where

$$d_i = \text{draft amidships for the relevant loading conditions}$$

The roll natural motion period:

$$T_r = 2 k_r / GM^{0.5} \text{ seconds}$$

where

$k_r$  = roll radius of gyration, in m, and may be taken as 0.35B for full load conditions and 0.45B for ballast conditions.

$GM$  = metacentric height, in m, to be taken as:

= GM (full) for full draft

= 1.5 GM(full) for  $3/4 d_f$

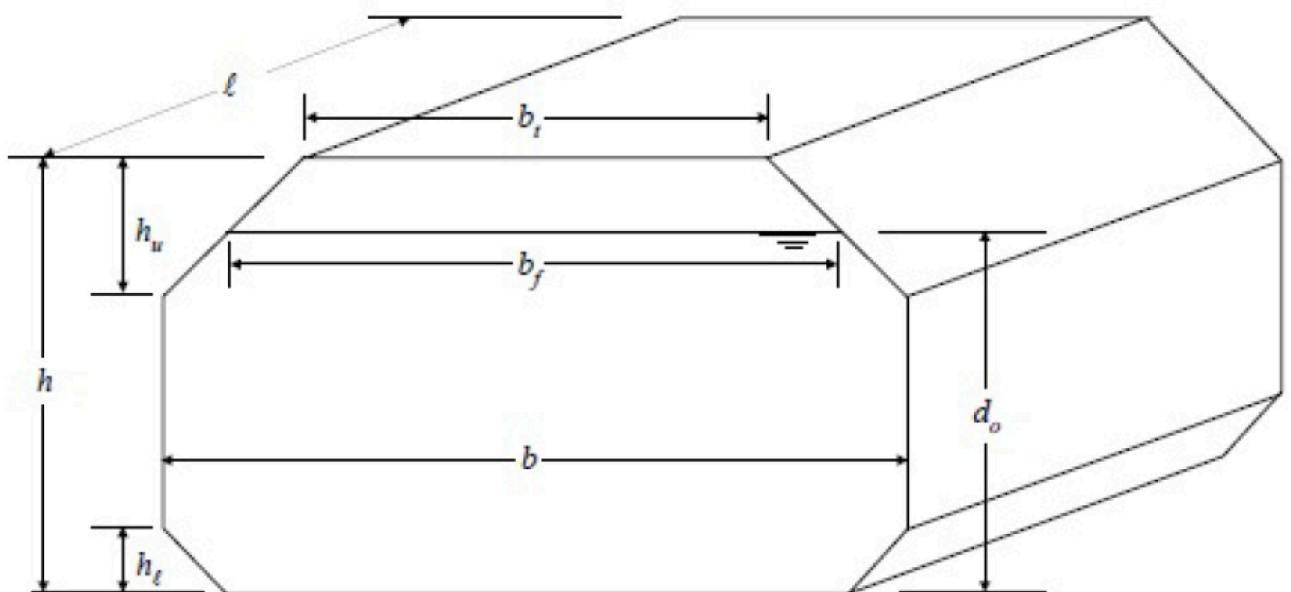
= 2.0 GM(full) for  $2/3 d_f$

$GM(\text{full})$  = metacentric height for fully loaded condition

= 0.12B in case  $GM(\text{full})$  is not available.

$B$  = width of vessel

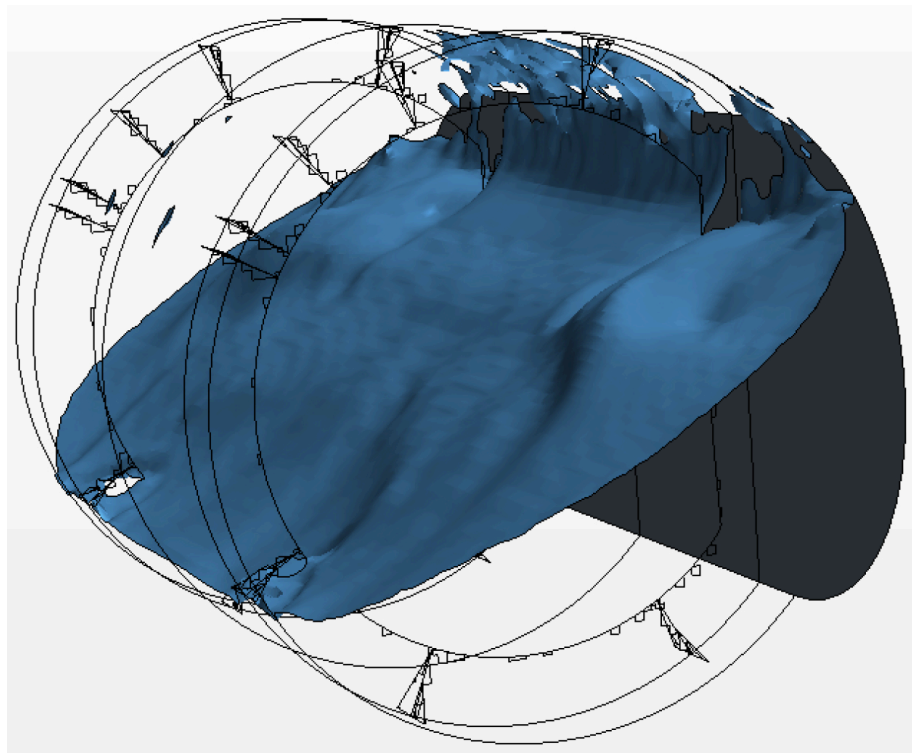
**FIGURE 6 Definition of Tank Geometry**



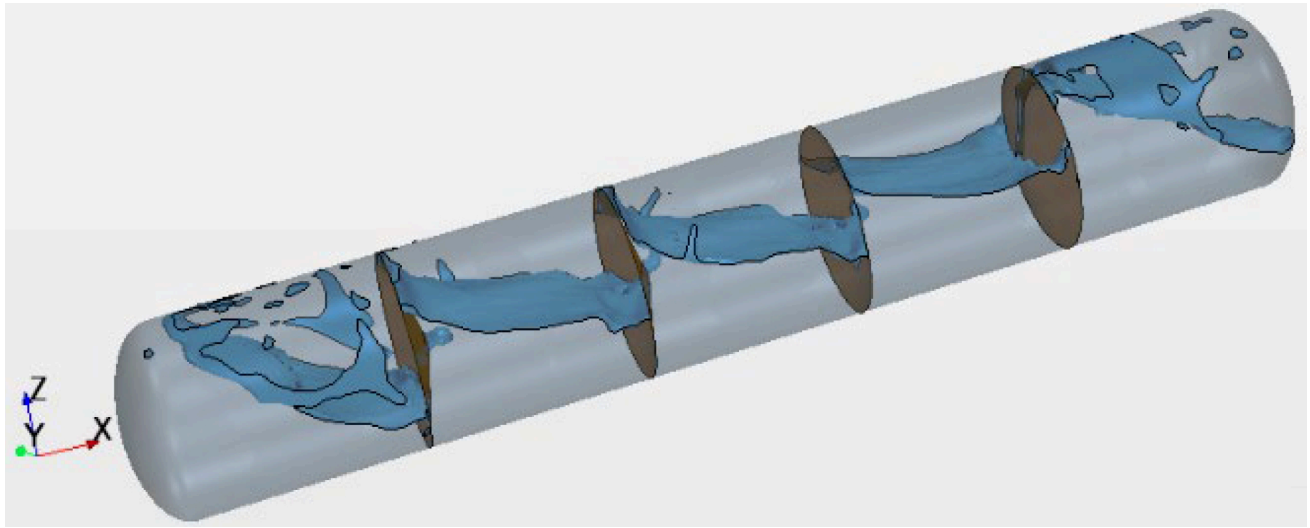
Based on the above liquid sloshing natural period, a simple evaluation can be conducted to determine the need for further sloshing assessment. The wave frequency in the Critical Sloshing Wave Domain (CSWD) should satisfy the following criteria, which require significance of sloshing motion parameters and proximity of the encountering frequency to the sloshing natural frequency: Encountering period is within 30% range of the sloshing natural period. Detailed sloshing assessment may be based on sloshing model tests or CFD simulations. For simple tank shapes, the sloshing loads can be determined using first principle impulse-momentum calculations. 5C-12-3/11 of the *Marine Vessel Rules* can be referred to calculate sloshing loads for a partial filling. For complex tank shapes, the sloshing loads can be typically determined using CFD simulations or sloshing model tests. Section 2, Figure 7 gives an example of CFD sloshing simulation for a bi-lobe cargo tank installed in an LNG carrier. Section 2, Figure 8 shows the CFD sloshing simulation for the LNG fuel tank with four splash baffles installed.

The CFD approach can be employed to reasonably determine natural frequencies with different filling ratios. For each given filling level, the natural frequency can be determined through a free decay test, applying an impulse velocity to fluid inside the tank as the initial condition. The fluid motion at a representative location is output in the form of decaying sinusoidal time history. The CFD outputs can be taken as the frequency of excitation motion (e.g., acceleration) for further sloshing simulations. Following the operation manual, all loading conditions need to be considered and the worst scenario should be examined. If the acceleration is taken as an excitation motion, the acceleration components can be calculated based on 2/2.1.5(a). The maximum acceleration can be taken as the amplitude of excitation acceleration. Therefore, the excitation motion obtained based on the above procedure can be applied as a regular motion for CFD sloshing simulations. Thus, the force vs. time history on the tank and sloshing baffle plates can be determined and employed as applied loads for FE stress analysis.

**FIGURE 7**  
**CFD Sloshing Simulation in a Bi-Lobe Tank**



**FIGURE 8**  
**CFD Sloshing Simulation in a Fuel Tank**



### 2.1.7 Accidental Loads

Accidental loads are defined as loads that are imposed on a cargo/fuel tank and its supporting structures under abnormal and unplanned conditions. Based on the requirements in Part 5C, Chapter 8 and Part 5C, Chapter 13 of the *Marine Vessel Rules*, the following accidental loads would need to be considered:

- *Collision Forces*: Independent Type C tanks need to be designed to withstand collision forces corresponding to  $a_x = 0.5g$  along the longitudinal direction in the forward direction and  $a_x = 0.25g$  in the aft direction, without deformation that would likely endanger the integrity of the tank structure.
- *Buoyant Force*: When independent Type C tanks are installed in enclosed spaces, they need to be capable of withstanding an upward force caused by buoyancy acting on the empty tank when the enclosed space is flooded to the summer load line draft of the vessel.

According to load components discussion in the above paragraphs in this Section, design load cases for yielding, buckling, and fatigue assessment are defined in the next Section.

## 2.2 Design Load Cases

### 2.2.1 Design Load Cases for Yielding and Buckling Assessment

As required by Part 5C, Chapter 8 and Part 5C, Chapter 13 of the *Marine Vessel Rules*, the strength of the independent Type C tank and supporting structures should be checked against yielding, buckling, and fatigue. For each failure mode, all design load cases including sea condition and accidental loading conditions need to be considered and applied to the tank and supporting structures. The buckling requirements are generally given for cylindrical shells and torispherical or ellipsoidal ends exposed to external pressure (and in some cases to internal pressure).

Based on the most severe loading condition that could occur during service life, the strength of tank, supports and relevant connections are evaluated against yielding and buckling failure under eight Design Load Cases below. In each Load Case, the resultant load should include all listed load components.

#### Standard Load Case 1 – Static and dynamic loads

- Self-weight of tank system

- Design vapor pressure
- Hydrostatic pressure due to gravity
- Hydrodynamic pressure due to accelerations
  - Vertical acceleration (predominantly due to heave and pitch)
  - Transverse acceleration (predominantly due to sway, yaw and roll)
  - Longitudinal acceleration (predominantly due to surge and pitch)
- External overpressure (vacuum-insulated double-shell tank)

#### **Standard Load Case 2 – Static loads at 30° heeling**

- Self-weight of tank system
- Design vapor pressure
- Hydrostatic pressure due to 30° heeling
- External overpressure (vacuum-insulated double-shell tank)

#### **Standard Load Case 3 – Sloshing loads**

- Design vapor pressure
- Sloshing loads
- External overpressure (vacuum-insulated double-shell tank)

#### **Standard Load Case 4 – Buckling check**

- Empty tank
- External overpressure (setting value of vacuum relief valves; vacuum-insulated double-shell tank)

#### **Accidental Load Cases 5 and 6 - Collision loads**

- Design vapor pressure
- Hydrostatic pressure due to gravity
- Hydrodynamic pressure due to longitudinal acceleration
  - 0.5g in the forward direction
  - -0.25g in the afterword direction
- External overpressure (vacuum-insulated double-shell tank)

#### **Accidental Load Case 7 – Flooding loads**

- Design vapor pressure
- Hydrostatic pressure
- Buoyant load on an empty tank in submerged condition
- External overpressure (vacuum-insulated double-shell tank)

#### **Tank Test Load Case 8 – Testing Loads**

- Hydrostatic testing pressure

In the sea condition, dynamic loads such as hydrodynamic pressure are mainly caused by wave-induced accelerations including longitudinal, transverse, and vertical accelerations, respectively. Thus, the hydrostatic and hydrodynamic pressure caused by liquid acceleration and gravity in the fully loaded condition, respectively, are considered as Load Case 1, referring to Section 2/2.1.5(b). Static loads corresponding to the most unfavorable static heel angle within the range  $0^\circ$  to  $30^\circ$  are considered as Load Case 2, referring to Section 2/2.1.3. Another dynamic load is sloshing loads due to the tank motion, considered as Load Case 3, referring to Section 2/2.1.6. As Load Case 4, the buckling check should be performed considering the difference between external and internal pressures. For vacuum-insulated tanks, external pressure is the pressure on the outer tank caused by the evacuation between outer tank and inner tank for buckling check.

According to the requirements in Part 5C, Chapter 8 and Part 5C, Chapter 13 of the *Marine Vessel Rules*, independent Type C tanks including supports and connections must survive in accidental cases such as collision and flooding. Collision loads are considered including forward/afterward collisions with other objects as Load Cases 5 and 6, which comprise internal pressure and hydrostatic and hydrodynamic pressure resulting from liquid gravity and dynamic acceleration, as well as external pressure (only applicable for vacuum-insulated tanks). Water submerged flooding is a worst case for a Type C tank being flooded over the top by seawater, wherein the buoyant load is applied as hydrostatic pressure accordingly as Load Case 7.

Additionally, each pressure vessel should be subjected to hydrostatic or hydropneumatic pressure testing at a pressure measured at the top of the tanks, of not less than  $1.5P_0$  as Load Case 8. In no case during the pressure test should the calculated primary membrane stress at any point exceed 90% of the yield stress of the material. To confirm that this condition is satisfied where calculations indicate that this stress will exceed 0.75 times the yield strength, the prototype test should be monitored by the use of strain gauges or other suitable equipment in pressure vessels other than simple cylindrical and spherical pressure vessels.

### 2.2.2 Design Load Cases for Fatigue Assessment

The design basis for independent Type C tanks is based on pressure vessel criteria modified to include fracture mechanics and crack propagation criteria. The minimum design pressure as defined in 2/2.1.1 is intended to provide a sufficiently low dynamic stress, so that an initial surface flaw will not propagate more than half the thickness of the shell during the lifetime of the tank.

In this case, the Type C tank is mainly subjected to the static pressure. For a traditional single-wall Type C tank, fatigue and crack propagation can be assumed to be non-critical. In this case, fatigue assessment may not be required for the Type C tank design.

However, for a large Type C tank such as Type C multi-lobe tanks (e.g., bi-lobe, tri-lobe tanks, etc.), the tank joints, especially in way of supports and the connections between the cylinders and their longitudinal bulkhead (e.g., Y-joint), should be evaluated for fatigue assessment.

Additionally, for a Type C vacuum-insulated tank, it should be noted that the scope for strength evaluation of the vacuum-insulated tanks normally exceeds those of a traditional Type C tank, with particular focus on the fatigue and ultimate strength of the inner tank in way of the inter barrier supports. In the design of a vacuum-insulated Type C tank, the annular space between the inner tank and the outer vacuum jacket is typically not accessible for in-service inspection throughout the life of the tanks. In such cases, all structural elements, such as support frames, and welded connections located in the annular space are required to have a fatigue life not less than 10 times the minimum design life of the ship.

When a fatigue analysis is required by the pressure vessel code, which is used to design a Type C tank, or by the flag Administration or Class Society of the vessel, then the cumulative fatigue damage should be assessed for both high cycle and low cycle fatigue loads.

High cycle fatigue damage principally occurs due to tank inertia loads caused by ship motion. For high cycle fatigue analysis, the extreme dynamic accelerations of the tank, the long-term prediction of wave loads, the wave spectra covering the North Atlantic Ocean and a probability level of  $10^{-8}$  will generally be employed. Then, a load factor for adjusting the probability of exceedance is considered for fatigue assessment at a probability level of  $10^{-4}$ .

Low cycle fatigue damage is principally caused by cargo/fuel loading and unloading in the tank over a complete thermal and pressure cycle. In the *LGC Guide*, four load pairs (Load Pairs 1 - 4) for high cycle fatigue due to the wave-induced motion are defined for full load condition and normal ballast condition, respectively, as shown in Section 2, Table 1.

When considering a cargo tank in a liquefied gas carrier, it is usually assumed that half of vessel's life is spent at a full load condition and the other half at a normal ballast condition. However, for a liquefied gas fuel tank, it is assumed that the tank is at the worst case (highest acceleration) loading and ballast condition for its full life.

Section 2, Table 1 gives the acceleration factors for each fatigue load case corresponding to high cycle fatigue. 75% design speed is considered when calculating vessel accelerations. In FE analysis, the resultant acceleration with its magnitude and direction, which is calculated by acceleration components considering acceleration factors listed in Table 1, can be employed to determine the internal pressure inside the tank. Additionally, low cycle fatigue damage should be considered under a complete pressure and thermal cyclic loads due to cargo/fuel loading/unloading (Pair 5). For Load Pair 5, both pressure and thermal loads due to a complete loading/unloading are assumed from the design internal pressure and the cargo/fuel temperature in the full load condition to the ballast pressure and the temperature in the ballast condition.

**TABLE 1**  
**Design Load Cases for Fatigue Strength Assessment**  
**(Acceleration Factors for Full & Ballast Load Conditions)**

<i>Load Case Pair</i>	<i>LC1 &amp; LC2</i>		<i>LC3 &amp; LC4</i>		<i>LC5 &amp; LC6</i>		<i>LC7 &amp; LC8</i>	
Wave Heading	0° head		0° head		90° beam		60° oblique	
Local Pressure Load Case	LC1	LC2	LC3	LC4	LC5	LC6	LC7	LC8
Longitudinal Acceleration $k_{cl}$	0.00	0.00	0.00	0.00	0.00	0.00	0.00	0.00
Vertical Acceleration $k_{cv}$	0.50	-0.50	1.00	-1.00	0.40	-0.40	0.20	-0.20
Transverse Acceleration $k_{ct}$	N/A	N/A	N/A	N/A	-0.70	0.70	-0.40	0.40

## Structural Analysis of Tank and Supporting Structures

### 1 General

An independent Type C tank can be designed as a foam-insulated single-shell structure or a vacuum-insulated double-shell structure. There are various kinds of shapes of Type C tanks, such as cylindrical, bi-lobe, tri-lobe, etc. For liquefied gas carriers, either cylindrical or bi-lobe Type C tanks are typically fitted in small and medium vessels. For fuel tanks, vacuum-insulated Type C tanks are the most typical among existing gas fueled ships.

To support the independent Type C tank, one end of saddle supports is constrained to the hull, and another end is designed to be able to slide freely to compensate for the effect of thermal contraction/expansion caused by the temperature change due to cargo/fuel loading and unloading. To assess structural integrity, generally the first-principles approach using the finite element (FE) method is employed for structural analysis of the tank and supporting structures in design load cases. In general, yielding, buckling, and fatigue evaluation of the tank and supporting structures should be conducted.

Under different design load cases, which are defined in 2/2.2.1, stress and buckling FE analyses are performed to calculate the maximum stress against the yielding strength and the design pressure against the critical buckling pressure. Fatigue assessments of Type C tanks may be required in some special cases (e.g., for large independent Type C tanks with Y-connections in the form of multi-lobes (bi-lobes, tri-lobes, etc.) as well as vacuum insulated fuel tanks). Fatigue assessment under fatigue load pairs, which are defined in 2/2.2.2, should be performed including high cycle fatigue and low cycle fatigue under cyclic loads.

### 2 Finite Element (FE) Modeling

The FE model for the tank and supporting structures should include the tank wall, all major components inside the tank, and detailed supporting structure. Linear quadratic shell elements are recommended to model the structure made of thin plates such as tank shells, stiffener rings, bulkheads, saddle frames and webs, partial hull structure, etc., and linear triangular shell elements may be employed in transition areas when necessary. Linear hexahedral solid elements are recommended to model bulk material such as presswood blocks or mastic, which are typically shaped in a regular topology, and linear wedge or quadratic tetrahedral elements should be used as needed.

The FE mesh size should be fine enough to describe the geometric details such as small curvatures or surface intersections. For contact interfaces, stiffener rings, and saddle webs, a sufficient number of elements should be used across the characteristic width of these features. A convergence study of mesh size may need to be conducted to obtain reliable results. The mechanical properties of materials such as Young's modulus and Poisson's ratio should be considered in FE modeling following material specifications for a specific tank design.



For example, for a bi-lobe Type C tank, two cylindrical shells form the tank and a hemisphere is used for the tank caps to hold the liquefied gas cargo. The tank and its supports consist of major components which include the tank shell, ring stiffeners, the longitudinal central bulkhead, and saddle supports. The presence of the longitudinal central bulkhead may change the stress distribution in the tank so that the evaluation of the bulkhead structure and the Y-connection at the intersection between longitudinal bulkhead and tank shell should be considered. For the Y-connection and stiffening rings, special attention should be paid to the stress concentration due to geometry change.

The vacuum-insulated Type C fuel tank usually consists of major components such as an inner tank, an outer jacket, inside supports between two shells, and outside (saddle) supports. The inner tank, which holds the gas fuel and is subject to high internal pressure and low temperature, is the most critical component. For thermal insulation purposes, an outer tank is designed to be evacuated for holding the insulation materials in the space between the inner tank and outer jacket. The inner tank and the outer tank are connected by the inside support system, which usually consists of a support at one end of inner tank and a support at another end. Inside the inner tank, several splash baffles are implemented to prevent sloshing caused by the tank motion, since the sloshing loads against tank wall and internal members may be significant when partially loaded. The outside support system consists of two saddle supports, which are welded to the exterior surface of outer tank and connected to the hull.

In FE modeling, the FE model for a bi-lobe tank should include the tank shell, ring stiffeners, the longitudinal central bulkhead, and saddle supports. Section 1, Figure 1 shows example FE models of a cylindrical Type C tank and a bi-lobe tank with their saddle supports. The FE model for a vacuum insulated tank should include inner tank, outer jacket, inside supports between two shells and outside (saddle) supports. Section 1, Figure 3 shows an example FE model of a vacuum-insulated tank with its supports.

### 3 Loading and Boundary Conditions

In structural analysis, design loads need to be determined for designing independent Type C tank structure and its supports. Typical loads for the design of a cryogenic pressure vessel include pressure loads due to tank pressurization, thermal loads during the cooling down period and due to temperature variations during the loading/unloading of liquid cargo/fuel or initial cooling down period, deadweight of the tank and its contents, and reaction loads due to supports and attachments.

Additionally, the unique loads associated with operation in a marine environment also need to be considered. Following the description in 2/2.1, both static and dynamic loads for each Load Case are applied to tank and support structures for conducting FE stress analyses.

There are usually two end supports designed for an independent Type C tank. At the sliding support, five degrees of freedom (DOF) are constrained, and only the longitudinal translation in  $x$  direction is free. At the fixed support, all six DOFs are constrained as the boundary conditions.

### 4 Stress Analysis

The loads and boundary conditions discussed above are applied to the FE model containing the tank and support structures. FE analysis on the tank and support model can be conducted using commercial software such as ABAQUS.

The magnitude of displacements is taken from FE results to demonstrate the deformation of tank and supporting structures, and von-Mises stress distributions, especially peak values at critical locations in the structure, are determined in the whole model with all components such as tank skin, ring stiffeners, and saddle supports, respectively.

For a vacuum insulated tank, the deformation and von-Mises stress distributions are obtained in the whole model with all components such as inner tank, outer tank, inside supports between two shells, and outside saddle supports.

The yielding check can be done for all components in tank and supporting structures according to the stress classification defined in the ASME BPVC.VIII.2.

## 5 Buckling Analysis

The thickness and form of pressure vessels, which are subjected to external pressure and other loads causing compressive stresses, should be determined based on calculations using pressure vessel buckling theory. The difference between theoretical and actual buckling stresses should be adequately accounted for, including plate edge misalignment, ovality, and deviation from true circular form over a specified arc or chord length.

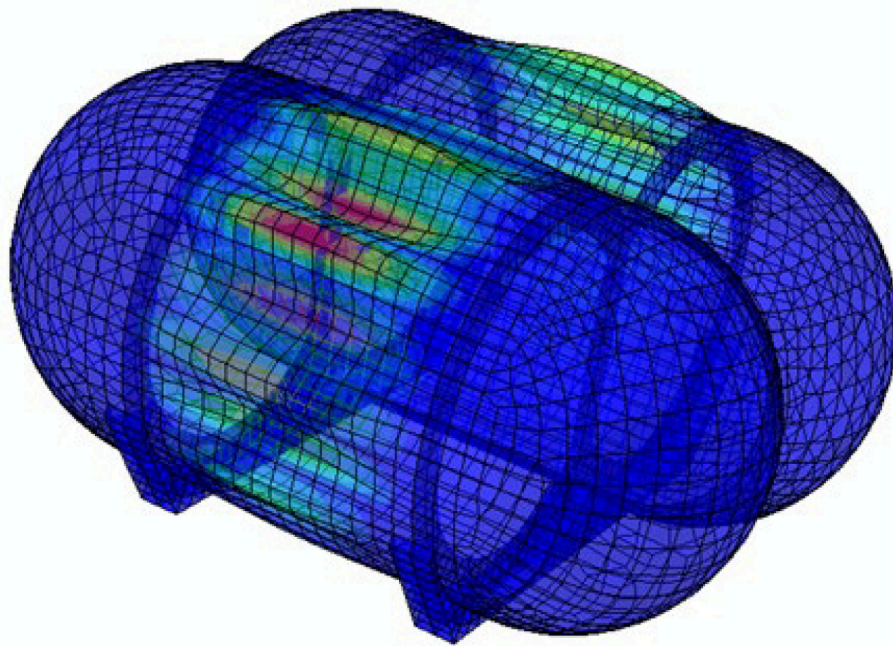
The loads for the buckling check include, but are not limited to, external overpressure, flooding pressure, shell weight, etc. Different buckling modes can be obtained from eigenvalue FE analysis. It should be noted that the mesh size is significantly important, and the coarse mesh can overestimate the eigenvalue results, leading to higher critical buckling loads.

The critical buckling pressure of the tank can be determined by two FE simulation methods as follows:

- Linear buckling (eigenvalue) analysis
- Post-buckling analysis with imposed imperfection

Linear buckling (eigenvalue) analysis requires the elastic material properties of the tank and a unit buckling load distribution applying on the tank to solve for eigenvalues for corresponding buckling modes. In general, the first buckling mode with the lowest eigenvalue represents the critical buckling load which the magnitude is the multiplication of the eigenvalue and the applied unit buckling load. In addition, local buckling should be checked against buckling failure, particularly when torispherical heads are designed for tanks and domes. Section 3, Figure 1 gives an example of buckling mode for a bi-lobe tank from eigenvalue analysis.

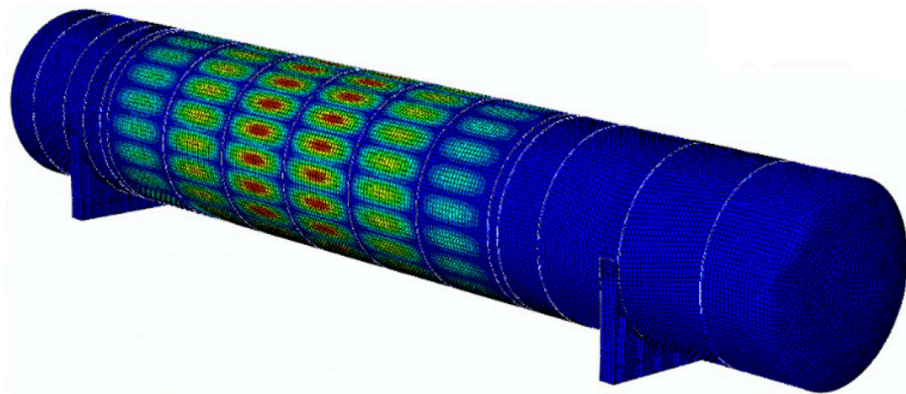
**FIGURE 1**  
**Example of Buckling Mode for a Bi-Lobe Tank**



The value of critical buckling load can be affected by tank imperfections, such as out-of-roundness or any shape deviation due to manufacturing tolerance. When the imperfection of a tank is significant, a post-buckling analysis should be carried out to determine the critical buckling load. Elastic-plastic material properties are needed, and a load distribution is applied to the tank that contains the imperfection to be considered. The imperfection field can be obtained through actual measurement, manufacturing tolerance, or buckling mode shapes derived from eigenvalue analysis. To determine the value of the buckling load, the result of load vs. displacement plot is generated, where the displacement is drawn at the location of interest or the point which can produce the largest displacement in the tank due to the load. The limit point of the load-displacement curve defines the magnitude of critical buckling load. It is noted that post-buckling analysis is a highly non-linear analysis and may involve unstable collapse behaviors such as snap-through or snap-back.

For a vacuum-insulated fuel tank, two buckling load cases need to be considered. First, an external pressure is applied to the outer tank for eigenvalue analysis. Second, an external pressure is applied as preload, and the hydrostatic pressure due to submerging is an incremental load. As an example, Section 3, Figure 2 gives another example of buckling mode of outer tank under the overpressure from eigenvalue analysis. The tank bottom buckles first because of higher hydrostatic pressure in this case.

**FIGURE 2**  
**Example of Buckling Mode of a Vacuum-Insulated Tank under Overpressure**



## 6 Fatigue Analysis

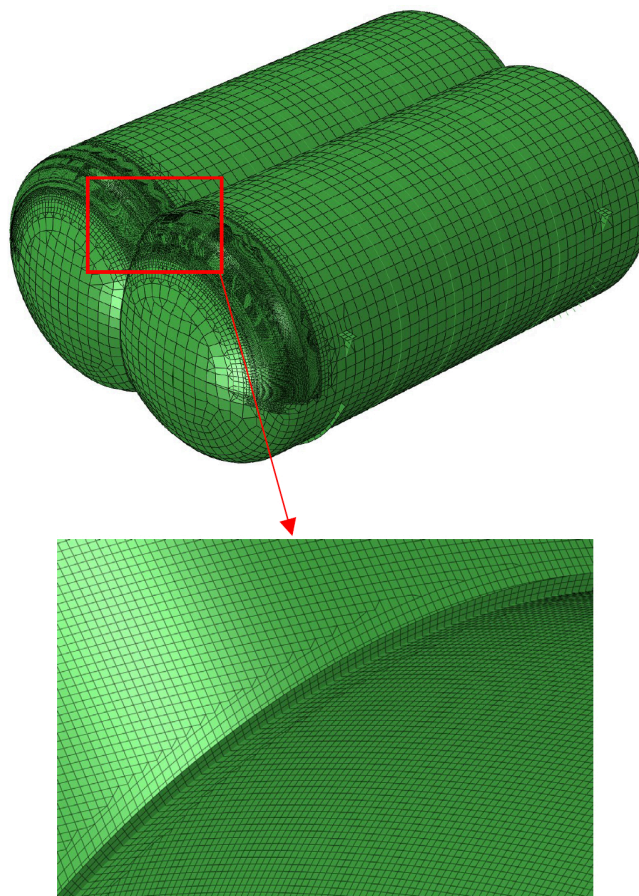
In general, the fatigue assessment for Type C tanks is not required. However, it can be considered necessary in some cases according to 5C-8-4/23.4 and 5C-13-6/4.15.3.4 of the *Marine Vessel Rules*.

For the fatigue design condition in Section 5C-8-4 of the *Marine Vessel Rules* for large independent Type C cargo tanks, where the cargo at atmospheric pressure is below  $-55^{\circ}\text{C}$ , the Administration or recognized organization acting on its behalf may require additional verification to confirm their compliance with 5C-8-4/23.1.1 of the *Marine Vessel Rules* regarding static and dynamic stress.

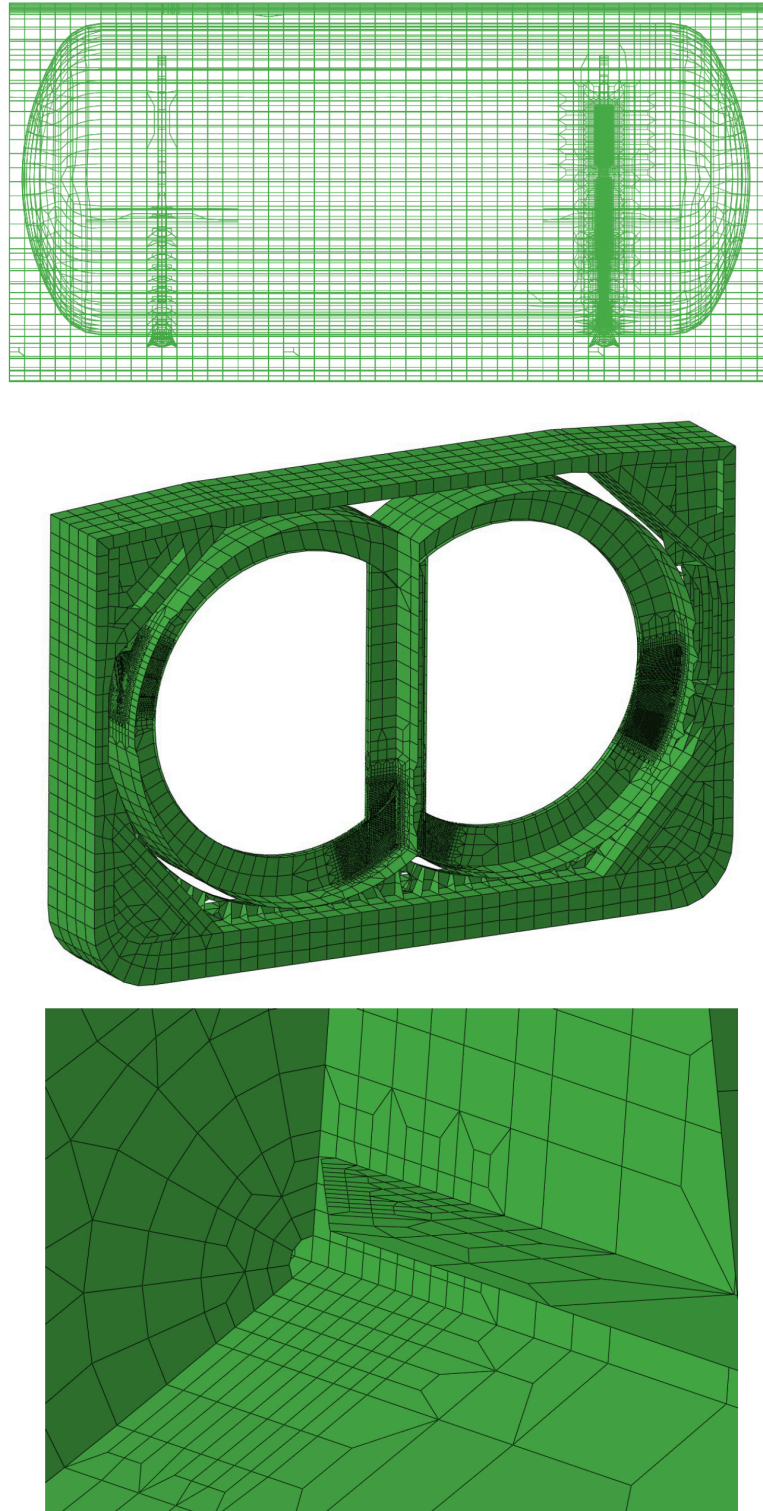
For the fatigue design condition in Part 5C, Chapter 13 of the *Marine Vessel Rules*: independent Type C fuel tanks where the temperature of liquefied gas fuel at atmospheric pressure is below  $-55^{\circ}\text{C}$ , the Administration may require additional verification to confirm compliance with 5C-13-6/15.3.1.1 of the *Marine Vessel Rules*, regarding static and dynamic stress depending on the tank size, the configuration of the tank and the arrangement of its supports and attachments.

Section 3, Figure 3 shows FE mesh for a large Type C bi-lobe tank with local refined mesh near the connection between two cylindrical shells. Section 3, Figure 4 shows FE mesh near Y-joint between two cylindrical shells and the central bulkhead.

**FIGURE 3**  
**FE Mesh for a Bi-Lobe Tank**

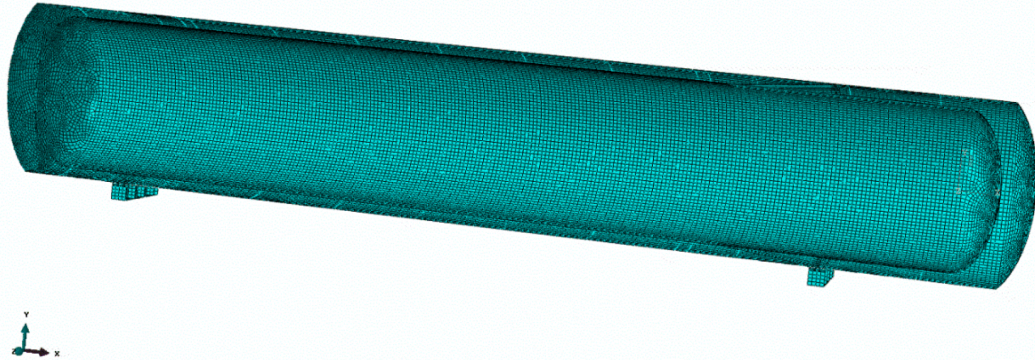


**FIGURE 4**  
**FE Mesh near Y- Joint for a Bi-Lobe Tank**



For vacuum insulated tanks, as shown in Section 3, Figure 5, special attention should be paid to the fatigue strength of structural components inside the inner tank and the support design between the inner tank and the outer jacket due to limited ability for inspection between inside and outer shells.

**FIGURE 5**  
**Vacuum-Insulated Double Shell Tank**



The fatigue strength assessment should be performed on critical areas such as welding and connection areas in tank and supporting structures. The total cumulative fatigue damage should include wave induced high cycle fatigue and cargo/fuel loading and unloading induced low cycle fatigue.

### 6.1 High Cycle Fatigue

High cycle fatigue damage principally occurs due to tank inertia loads caused by the motion of the vessel. For the high cycle fatigue analysis, the extreme dynamic accelerations of the tank, the long-term prediction of wave loads, the wave spectra covering the North Atlantic Ocean, and a probability level of  $10^{-8}$  would generally be employed. Then, a load factor for adjusting the probability of exceedance is considered for fatigue assessment at a probability level of  $10^{-4}$ . The cumulative fatigue damage is calculated on the basis of an appropriate S-N curve assuming linear cumulative damage (Palmgren-Miner Rule).

Referring to the *LGC Guide*, the cumulative fatigue damage for loading condition  $i$  for high cycle fatigue can be calculated as:

$$D_{fi} = \frac{1}{6}D_{fi_{12}} + \frac{1}{6}D_{fi_{34}} + \frac{1}{3}D_{fi_{56}} + \frac{1}{3}D_{fi_{78}}$$

where  $D_{fi_{12}}$ ,  $D_{fi_{34}}$ ,  $D_{fi_{56}}$ , and  $D_{fi_{78}}$  are the fatigue damage accumulated due to Load Case pairs 1&2, 3&4, 5&6, and 7&8, respectively (see Section 4, Tables 3 and 4 of the *LGC Guide* for load case pairs).

Assuming the long-term distribution of stress ranges follows the Weibull distribution, the fatigue damage accumulated due to load pair  $jk$  in loading condition  $i$ :

$$D_{fi_{jk}} = \frac{\alpha_i N_T}{K_2} \frac{f_{Ri_{jk}}^m}{(\ln N_R)^{m/\gamma} \mu_{i_{jk}}} \Gamma\left(1 + \frac{m}{\gamma}\right)$$

where

- $N_T$  = number of cycles in the design life
- =  $\frac{f_0 D_L}{4 \log L}$
- $f_0$  = 0.85, factor for net time at sea
- $D_L$  = design life in seconds,  $6.31 \times 10^8$  for a design life of 20 years
- $L$  = ship length
- $m, K_2$  = S-N curve parameters

- $\alpha_i$  = proportion of the ship's life  
 $\alpha_1 = 0.5$  for full load condition  
 $\alpha_2 = 0.5$  for normal ballast condition
- $f_{Ri\_jk}$  = stress range of load case pair  $jk$  at the representative probability level of  $10^{-4}$ , in kgf/cm<sup>2</sup>  
 For the welded connections with thickness  $t$  greater than 22 mm,  $f_{Ri\_jk}$  is adjusted by a factor  $(t/22)^{0.25}$ . The thickness correction is not applicable to the longitudinal stiffeners which are of flat bars or bulb plates.  
 If it can be conclusively established that the detail under consideration is always subject to a mean stress of  $\sigma_m$ ,  $f_{Ri\_jk}$  is adjusted by a factor  $\kappa_m$
- $\kappa_m$  = 1.0 for  $\sigma_m > f_{Ri\_jk}/2$   
 =  $0.85 + 0.3 \sigma_m / f_{Ri\_jk}$  for  $-f_{Ri\_jk}/2 \leq \sigma_m \leq f_{Ri\_jk}/2$   
 = 0.7 for  $\sigma_m < -f_{Ri\_jk}/2$
- $N_R$  = 10000, number of cycles corresponding to the probability level of  $10^{-4}$
- $\gamma$  = long-term stress distribution parameter as defined in A3/5.5
- $\Gamma$  = Complete Gamma function
- $\mu_{i\_jk} = 1 - \left\{ \frac{C \left( 1 + \frac{m}{\gamma}, v_{i\_jk} \right) - v_{i\_jk}^{-\Delta m / \gamma} \Gamma_0 \left( 1 + \frac{m + \Delta m}{\gamma}, v_{i\_jk} \right)}{\Gamma \left( 1 + \frac{m}{\gamma} \right)} \right\}$
- $v_{i\_jk} = \left( \frac{f_q}{f_{Ri\_jk}} \right)^\gamma \ln N_R$
- $f_q$  = stress range at the intersection of the two segments of the S-N curve
- $\Delta m$  = 2, slope change of the upper-lower segment of the S-N curve
- $\Gamma_0( )$  = incomplete Gamma function, Legendre form

The reference stress range for each Load Pair shown in Section 2, Table 1 can be determined based on FE analysis results. Thus, the total fatigue damage considering all Load Pairs for high cycle fatigue can be calculated.

## 6.2 Low Cycle Fatigue

For low cycle fatigue, a complete pressure and thermal cycle should be considered for cargo loading/unloading. The pressure load and the thermal load due to a complete cargo loading/unloading are assumed from the design pressure and the cargo/fuel temperature in the full load conditions to the ballast pressure and the temperature in the ballast load condition.

The cumulative fatigue damage ratio for cargo loading/unloading induced thermal and pressure cyclic loads can be calculated by  $\frac{n_{Loading}}{N_{Loading}} \cdot n_{Loading}$  is taken as the minimum of 1000 cycles. Based on the S-N curve of the material, using the maximum stress range for a complete thermal and pressure cycle,  $N_{Loading}$  can be determined as the number of low cycles until fatigue failure.

In the summary of fatigue analysis, the cumulative fatigue damage would be calculated based on an appropriate S-N curve assuming linear cumulative damage (Palmgren-Miner Rule) referring to the *LGC Guide*. For both high cycle and low cycle fatigue damage calculations, the maximum principal stress range is usually taken from the FE analysis results of the Type C tank. Critical areas with hot spot stress in the tank and supporting structure are identified in the FE results for fatigue assessment considering all fatigue load cases.

## Strength Assessment of Type C Tank and Supporting Structures

### 1 General

The strength evaluation of independent Type C cargo/fuel tanks should be performed for all components in the tank and support structures, respectively, including yielding, buckling, and fatigue checks.

Based on acceptance criteria and material properties, the yielding strength should be assessed using the maximum von Mises stress for each individual structural component from FE stress analysis in design load cases.

Based on acceptance criteria, the buckling strength should be assessed using the critical buckling loads of the tank structure from FE eigenvalue analysis for buckling load case.

For fatigue strength evaluation, the maximum stress range at critical locations in the structure can be calculated using the principal stresses from FE stress analysis corresponding to each load pair, and then the stress range distributions can be determined following the Weibull distribution. The fatigue damage ratio should be calculated including both high cycle fatigue and low cycle fatigue loads. Wave-induced loads (four Load Pairs) are for high cycle fatigue and cargo/fuel loading/unloading induced loads (one Load Pair) are for low cycle fatigue. Based on acceptance criteria and material fatigue S-N curve, fatigue strength should be assessed at each critical location in tank and supporting structures.

### 2 Yielding Evaluation

The independent Type C cargo/fuel tank is designed as a pressurized tank under design load cases. FE results are assessed for yielding strength following the requirements in Part 5C, Chapter 8 and Part 5C, Chapter 13 of the ABS *Marine Vessel Rules* and the ASME BPVC.VIII.2. For Type C independent tanks, the allowable stresses should not exceed:

$$\begin{array}{rcl}
 \sigma_m & \leq & f \\
 \sigma_L & \leq & 1.5f \\
 \sigma_b & \leq & 1.5f \\
 \sigma_L + \sigma_b & \leq & 1.5f \\
 \sigma_m + \sigma_b & \leq & 1.5f \\
 \sigma_m + \sigma_b + \sigma_g & \leq & 3.0f \\
 \sigma_L + \sigma_b + \sigma_g & \leq & 3.0f
 \end{array}$$

where



$\sigma_m$	=	equivalent primary general membrane stress
$\sigma_L$	=	equivalent primary local membrane stress
$\sigma_b$	=	equivalent primary bending stress
$\sigma_g$	=	equivalent secondary stress
$f$	=	the lesser of $(R_m/A)$ or $(R_e/B)$
$R_e$	=	specified minimum yield stress at room temperature.

If the stress-strain curve does not show a defined yield stress, the 0.2% proof stress applies;  $R_m$  is specified minimum tensile strength at room temperature. The values  $A$  and  $B$  will be shown on the International Certificate of Fitness for the Carriage of Liquefied Gases in Bulk and should have at least the following minimum values:

**TABLE 1**  
**Values of A and B for Determination of Allowable Stress Criteria**

	<i>Nickel Steels and Carbon-Manganese Steels</i>	<i>Austenitic Steels</i>	<i>Aluminum Alloys</i>
A	3	3.5	4
B	1.5	1.5	1.5

Each pressure vessel should be subjected to a hydrostatic test at a pressure measured at the top of the tanks, of not less than  $1.5P_0$ , where  $P_0$  is design vapor pressure. In no case during the pressure test should the calculated primary membrane stress at any point exceed 90% of the yield stress of the material.

The mechanical properties of selected materials should follow the material specifications for each specific Type C tank. The mechanical properties of welding consumables should comply with AWS or other recognized standards.

### 3 Buckling Evaluation

The loads for buckling check should include, but are not limited to, external overpressure, insulation weight, and shell weight. The critical buckling pressure of a Type C tank can be determined under external overpressure or flooding pressure through FE eigenvalue analysis.

In the case of a vacuum insulated Type C tank, for the design case in which the outer tank is subjected to the external pressure caused by evacuation, the critical collapse pressure is determined through FE simulations.

For the accidental case, in which the outer tank is subjected to the flooding pressure in addition to the external pressure caused by evacuation, the external pressure should be applied as pre-load, and then flooding pressure should be applied for eigenvalue analysis to determine the critical buckling load.

If linear buckling (eigenvalue) analysis is performed, the safety factor against buckling failure should be 4.0 for unstiffened or ring stiffened cylinders and cones under external pressure, and 16 for spherical, torispherical, or elliptical heads under the external pressure. If post-buckling analysis considering an imperfection (e.g., out-of-roundness deviation) is performed, the safety factor against the buckling failure should be 3.0 for unstiffened or ring stiffened cylinders.

## 4 Fatigue Evaluation

As specified in Part 5C, Chapter 8 of the *Marine Vessel Rules*, the minimum design pressure for Type C tanks is intended to provide for a sufficiently low wave-induced dynamic stress related to static stress, so that an initial surface flaw will not propagate more than half the thickness of the tank wall during the lifetime of the tank. However, some critical areas such as welding and connection areas in tank and support structures may need assessment for the fatigue strength.

For example, for a large type C independent tank, some critical locations such as Y-connection with ring stiffeners at end support and near end cap for the bi-lobe or tri-lobe tank are required for fatigue evaluation to comply with the requirements in Part 5C, Chapter 8 and Part 5C, Chapter 13 of the *Marine Vessel Rules*. For a vacuum insulated Type C tank, the annular space between the inner tank and the outer vacuum jacket is typically not accessible for in-service inspection throughout the service life of the tanks. In such cases, an FE hot-spot stress fatigue analysis should be conducted on the inner tank and its supporting structures to satisfy the design fatigue life of at least ten times the minimum design life of the vessel in which the tank will be placed.

When a fatigue analysis is required by the pressure vessel code (used to design the Type C liquefied gas tank) or by the flag Administration or Class Society of the vessel, then the cumulative fatigue damage would need to be assessed for both high cycle and low cycle fatigue loading. For the high cycle and low cycle fatigue damage estimation, the stress results (maximum principal stress range) from the global FEA model of the liquefied gas tank are used. Highly stressed areas are selected from the FEA results considering all fatigue loading cases.

The fatigue design condition is the design condition with respect to accumulated cyclic loading. It includes the high cycle fatigue due to wave loads and the low cycle fatigue due to cargo loading/unloading. Where a fatigue analysis is required the cumulative effect of the fatigue load should comply with:

$$\sum_{i=1}^I \frac{n_i}{N_i} + \frac{n_{Loading}}{N_{Loading}} \leq C_w$$

where

$n_i$	=	number of stress cycles at each stress level during the life of the tank
$N_i$	=	number of cycles to fracture for the respective stress level according to the Wohler (S-N) curve
$n_{Loading}$	=	number of loading and unloading cycles during the life of the tank, normally taken as the minimum of 1000. Loading and unloading cycles include a complete pressure and thermal cycle
$N_{Loading}$	=	number of cycles to fracture for the fatigue loads due to loading and unloading
$C_w$	=	maximum allowable cumulative fatigue damage ratio

The fatigue damage should be based on the design life of the tank but not be less than  $10^8$  wave encounters. In detectable locations,  $C_w$  should be less than 0.5. However, as specified in Part 5C, Chapter 8 of the *Marine Vessel Rules*, in some locations of the tank where effective defect or crack development detection cannot be provided, the following, more stringent, fatigue acceptance criteria should be applied as a minimum:  $C_w$  should be less than or equal to 0.1. For example, at welding connections in inner shell for a double shell Type C tank, fatigue damage should be less than 0.1 during the design life.

Appropriate S-N curves should be used for the fatigue damage analysis. The selection of S-N curve depends on weld type, such as butt weld, transverse fillet weld, or longitudinal fillet weld. As examples, S-N curves for stainless steel, Aluminum alloy, and 9% Nickel steel refer to Appendix 5 of the *LGC Guide*.

## 5 Strength Evaluation of Supporting Structures

The strength of saddle support structures made of carbon manganese steel should be evaluated in accordance with 5C-8-4/8.1 (IACS) of the *Marine Vessel Rules*:

$$\sigma_e = \sqrt{(\sigma_n + \sigma_b)^2 + 3\tau^2} \leq \sigma_\alpha$$

where

$\sigma_e$  = equivalent stress (N/mm<sup>2</sup>)

$\sigma_n$  = normal stress in the circumferential direction of the stiffening ring (N/mm<sup>2</sup>)

$\sigma_b$  = bending stress in the circumferential direction of the stiffening ring (N/mm<sup>2</sup>)

$\tau$  = shear stress in the stiffening ring (N/mm<sup>2</sup>)

$\sigma$  = allowable stress (N/mm<sup>2</sup>), to be taken as the smaller of the values:  $0.57 R_m$  or  $0.85 R_e$

$R_e$  = specified minimum yield stress at room temperature (N/mm<sup>2</sup>). If the stress-strain curve does not show a defined yield stress, the 0.2% proof stress applies.

$R_m$  = specified minimum tensile strength at room temperature (N/mm<sup>2</sup>).

For stiffening rings inside the tank shell, the assumptions should be made in accordance with 5C-8-4/8.1.2 of the *Marine Vessel Rules*. The buckling strength of the stiffening rings should be examined.

For presswood supports, the safety factors against the yielding failure are 3.5 and 1.5 under standard load cases and accidental load cases, which are defined in 2/2.1, respectively.

## APPENDIX 1 References

- 1) IMO IGC Code: The International Code for the Construction and Equipment of Ships Carrying Liquefied Gases in Bulk.
- 2) IMO IGF Code: The International Code of Safety for Ships using Gases or other Low-flashpoint Fuels.
- 3) American Bureau of Shipping (ABS), Rules for Building and Classing Marine Vessels, Part 5C.
- 4) American Bureau of Shipping (ABS), Guide for Building and Classing Liquefied Gas Carriers with Independent Tanks.
- 5) American Bureau of Shipping (ABS), Guide for Building and Classing Floating Offshore Liquefied Gas Terminals.
- 6) American Bureau of Shipping (ABS), Requirements for Ammonia Fueled Vessels.
- 7) American Bureau of Shipping (ABS), Sustainability Whitepaper, Hydrogen as Marine Fuel.
- 8) ASME Boiler and Pressure Vessel Code, Section II, Part A.
- 9) ASME Boiler and Pressure Vessel Code, Section II, Part B.
- 10) ASME Boiler and Pressure Vessel Code, Section VIII, Division 2.
- 11) Bo Wang, Yung Shin and Xiaozhi Wang, “Structural Integrity Assessment of Independent Type ‘C’ LNG Carriers”, OMAE 2014, USA.
- 12) Bo Wang, Yung Shin and Eric Norris, “Strength Assessment of Type ‘C’ LNG Fuel Tanks”, OMAE 2015, Canada.

### 1 Austenitic SS304 Stainless Steel Mechanical Properties

Young's Modulus,  $E = 193 \text{ GPa}$

Poisson's ratio:  $\nu = 0.29$

SS304 grade stainless steel is a popular Austenitic stainless steel for cryogenic application down to  $-196^\circ\text{C}$ . In accordance with ASME BPVC. II. A, SA-240, it has the minimum required mechanical properties at room temperature as follows:

Minimum Yield Strength (0.2% offset):  $\sigma_y = 205 \text{ MPa}$

Minimum Tensile Strength:  $\sigma_u = 515 \text{ MPa}$

### 2 Aluminum Alloy (5083-O) Mechanical Properties

Young's Modulus:  $E = 71 \text{ GPa}$

Poisson's ratio:  $\nu = 0.33$

5083-O is applicable for cryogenic application down to  $-196^\circ\text{C}$ . In accordance with ASME BPVC. II. B, SB209, 5083-O has the minimum required mechanical properties at room temperature for specified thicknesses as follows:

<i>Thickness range, mm</i>	<i>Minimum Yield Strength, <math>\sigma_y</math> (0.2% offset), MPa</i>	<i>Minimum Tensile Strength, <math>\sigma_u</math>, MPa</i>
1.3 ~ 38	125	275
38 ~ 76	117	269
76 ~ 102	110	262

### 3 9% Nickel Steel Mechanical Properties

Young's Modulus:  $E = 200\sim 215 \text{ GPa}$

Poisson's ratio:  $\nu = 0.29$

A353 is a popular 9% Nickel steel applicable for cryogenic application down to  $-196^\circ\text{C}$ , which has the minimum mechanical properties at room temperature required by ASME BPVC. II. A, SA-353, as follows:

Minimum Yield Strength (0.2% offset):  $\sigma_y = 515$  MPa

Minimum Tensile Strength:  $\sigma_u = 690$  MPa

#### 4 5% Nickel Steel Mechanical Properties

Young's Modulus:  $E = 200\sim 215$  GPa

Poisson's ratio:  $\nu = 0.29$

A645 Grade B is a popular 5% Nickel steel applicable for cryogenic application down to  $-195^\circ\text{C}$ . A645 Grade B has the minimum mechanical properties at room temperature required by ASME BPVC. II. A, SA-645, as follows:

Minimum Yield Strength (0.2% offset):  $\sigma_y = 590$  MPa

Minimum Tensile Strength:  $\sigma_u = 690$  MPa

#### 5 Aluminum Alloy (6061-T6) Mechanical Properties

Young's Modulus:  $E = 68$  GPa

Poisson's ratio:  $\nu = 0.33$

6061-T6 is another applicable aluminum alloy for cryogenic application, which displays good fracture toughness in extreme cold temperature. 6061-T6 has the minimum mechanical properties at room temperature required by ASME BPVC. II. B, SB-209, as follows:

Minimum Yield Strength (0.2% offset):  $\sigma_y = 240$  MPa

Minimum Tensile Strength:  $\sigma_u = 290$  MPa

The welded mechanical properties, which should be considered in the design, are as follows:

Minimum Yield Strength:  $\sigma_y = 138$  MPa (under 9.5 mm thickness) and 103 MPa (over 9.5 mm thickness)

Minimum Tensile Strength:  $\sigma_u = 165$  MPa

#### 6 Austenitic SS316 Stainless Steel Mechanical Properties

Young's Modulus,  $E = 193$  GPa

Poisson's ratio:  $\nu = 0.25\text{-}0.30$

SS316 grade stainless steel is a popular Austenitic stainless steel for cryogenic application. In accordance with ASME BPVC. II. A, SA-240, it has the minimum required mechanical properties at room temperature as follows:

Minimum Yield Strength (0.2% offset):  $\sigma_y = 205$  MPa

Minimum Tensile Strength:  $\sigma_u = 515$  MPa