

Guide for Building and Classing

Floating Offshore Liquefied Gas Terminals



January 2024



GUIDE FOR BUILDING AND CLASSING

FLOATING OFFSHORE LIQUEFIED GAS TERMINALS
JANUARY 2024

**American Bureau of Shipping
Incorporated by Act of Legislature of
the State of New York 1862**

**© 2024 American Bureau of Shipping. All rights reserved.
ABS Plaza
1701 City Plaza Drive
Spring, TX 77389 USA**

Foreword (2024)

The industry and ABS share a large and successful body of experience with membrane tank Liquefied Natural Gas (LNG) carriers, independent tank liquefied gas carriers and ship-type FPSOs that have been designed to Part 5C, Chapter 12 of the *ABS Rules for Building and Classing Marine Vessels*, *ABS Guide for Building and Classing Liquefied Gas Carriers with Independent Tanks*, and *ABS Rules for Building and Classing Floating Production Installations (FPI Rules)*, respectively. The development of this *ABS Guide for Building and Classing Floating Offshore Liquefied Gas Terminals* is based on the design and analyses experience with these types of vessels.

This Guide provides criteria that can be applied in the Classification of the hull and tank structure of floating offshore liquefied gas terminals with membrane tanks or independent prismatic tanks. The Guide addresses liquefied gas terminals with ship-shaped or barge-shaped hull forms having a single row of cargo tanks at centerline or a row of two cargo tanks abreast. ABS recognizes that industry participation is a vital factor due to the rapidly progressing use of offshore gas terminals. To understand and apply this new technology and its standards, ABS, the offshore and onshore community and regulatory agencies can benefit from a common understanding of the terms and concepts involved, and an awareness of how these concepts are to be applied to ABS rule-making.

The hull strength criteria contained herein are to be considered as an alternative to those for corresponding aspects of Classification as given in Part 5C, Chapter 8 of the *Marine Vessel Rules* (MVR 5C-8) which includes requirements from the International Code for the Construction and Equipment of Ships carrying Liquefied Gases in Bulk (IGC Code). The Owner may elect to use either this Guide or MVR 5C-8. In the same design, for aspects of the hull structural design that are covered by both this Guide and MVR 5C-8 it is not valid to switch between the criteria in this Guide and MVR 5C-8. This Guide does not cover the design, fabrication and installation of the liquefied gas containment system, except for the structural design of independent tanks.

The June 2021 edition added the optional **FLM (number of years), Year** notation for position mooring system fatigue life, in line with the *FPI Rules*. This provides the flexibility to accept different fatigue life notations for position mooring and hull structure, including hull interfaces.

The December 2021 edition applied the **RFL** and **RFLM** notations to converted floating offshore liquefied gas terminals, similar to converted FPIs, following the methodology described in Section 5A-2-3 of the *ABS Rules for Building and Classing Floating Production Installations*.

The August 2023 edition provided requirements for the **Topside Modules** notation for topside module structures of a FLNG terminal in which gas processing, production and liquefaction facilities are not requested to be classed.

The January 2024 edition provides references to the *ABS Guide for Building and Classing Liquefied Gas Carriers with Independent Tanks* for the procedure and acceptance criteria of the crack propagation and fatigue fracture analysis for type B independent tanks.

This Guide becomes effective on the first day of the month of publication.

Users are advised to check periodically on the ABS website www.eagle.org to verify that this version of this Guide is the most current.

We welcome your feedback. Comments or suggestions can be sent electronically by email to rsd@eagle.org.

Changes to Conditions of Classification

Section 1-1, “Scope and Conditions of Classification” was consolidated into a generic booklet, entitled *Rules for Conditions of Classification – Offshore Units and Structures (Part 1)* for all units, installations, vessels or systems in offshore service. The purpose of this consolidation was to emphasize the common

applicability of the classification requirements in “Section 1-1” to ABS-classed offshore units, pipelines, risers, and other offshore structures, and thereby make “Conditions of Classification” more readily a common Rule of the various ABS Rules and Guides, as appropriate.

Thus, Section 1-1 of this Guide specifies only the unique requirements applicable to floating offshore liquefied gas terminals. These supplemental requirements are always to be used with the aforementioned *Rules for Conditions of Classification – Offshore Units and Structures (Part 1)*.

Reference Note

Reference to a paragraph in the *Marine Vessel Rules*, *MOU Rules* or *FPI Rules* is made in the format ‘P-C-S/ss.p’ where ‘P’ is the Part, ‘C’ is the Chapter, ‘S’ is the Section, ‘ss’ is the Subsection and ‘p’ is the Paragraph.

Reference to a paragraph in this Guide is made in the format ‘C-S/ss.p’, where ‘C’ is the Chapter, ‘S’ is the Section, ‘ss’ is the Subsection and ‘p’ is the Paragraph.

Reference to a Figure or Table in this Guide is made, respectively, in the format ‘C-S/Figure #’, or ‘C-S/ Table #’.



GUIDE FOR BUILDING AND CLASSING

FLOATING OFFSHORE LIQUEFIED GAS TERMINALS

CONTENTS

CHAPTER 1	Conditions of Classification.....	1
Section 1	Scope and Conditions of Classification (Supplement to the ABS Rules for Conditions of Classification - Offshore Units and Structures).....	2
CHAPTER 2	Design Considerations.....	7
Section 1	Classification of Floating Offshore Liquefied Gas Terminals.....	10
Section 2	Design of Floating Offshore Liquefied Gas Terminals.....	26
CHAPTER 3	Structural Design Requirements.....	47
Section 1	Introduction.....	60
Section 2	General Requirements.....	66
Section 3	Load Criteria.....	73
Section 4	Initial Scantling Criteria.....	137
Section 5	Total Strength Assessment.....	214
Section 6	Hull Structure Beyond 0.4L Amidships.....	229
Section 7	Design and Analysis of Other Major Hull Structural Features.....	245
Appendix 1	Guide for Fatigue Strength Assessment.....	254
Appendix 2	Calculation of Critical Buckling Stresses.....	293
Appendix 3	Determination of Environmental Severity Factors.....	303
Appendix 4	Hull Girder Ultimate Strength.....	307
Appendix 5	Hull Structural Modeling and Analysis.....	316
Appendix 6	Guide for Offshore Hull Construction Monitoring Program.....	347
CHAPTER 4	Surveys.....	349
Section 1	Surveys During Construction, Installation and Commissioning.....	351
Section 2	Surveys After Construction and Maintenance of Class.....	356
Section 3	Risk-based Surveys for Maintenance of Class.....	372

CHAPTER 1
Conditions of Classification

CONTENTS

SECTION	1	Scope and Conditions of Classification (Supplement to the ABS Rules for Conditions of Classification - Offshore Units and Structures).....	2
	1	Classification.....	2
	3	Purpose.....	2
	5	Classification Symbols and Notations.....	2
	5.1	Class Notations.....	2
	5.3	Geographical Limitations.....	3
	5.5	Floating Terminals Not Built Under Survey.....	3
	7	Rules for Classification.....	3
	7.1	Application of Rules.....	3
	7.3	Scope of Class.....	3
	7.5	Alternatives.....	3
	9	Units.....	4
	11	Abbreviations and References.....	4
	11.1	Abbreviations.....	4
	11.3	References.....	5

CHAPTER 1 Conditions of Classification

SECTION 1 Scope and Conditions of Classification (Supplement to the ABS Rules for Conditions of Classification - Offshore Units and Structures)

1 Classification

The requirements for conditions of classification are contained in the separate, generic *ABS Rules for Conditions of Classification - Offshore Units and Structures (Part 1)*.

Additional requirements specific to floating offshore liquefied gas terminals are contained in the following Subsections.

3 Purpose

A *Floating Offshore Liquefied Gas Terminal* provides liquefied gas storage and receives and/or offloads liquefied gas. There are two major variations of offshore liquefied gas terminal: Load Terminals and Discharge Terminals, with various configurations of each.

A *Load Terminal* receives gas directly from one or more wells or from another offshore facility where it may or may not have been processed. The gas is liquefied in an onboard liquefaction facility and stored for offloading as liquefied gas to a trading liquefied gas carrier. Alternatively, a *Load Terminal* may receive liquefied gas from a liquefaction plant via a pipeline.

A *Discharge Terminal* receives liquefied gas from trading liquefied gas carriers and stores it. In such terminals, the stored liquefied gas is normally vaporized in a re-gasification facility and discharged ashore. However, offloading liquefied gas in a lightering operation is also feasible.

5 Classification Symbols and Notations

A listing of Classification Symbols and Notations available to the Owners of vessels, offshore drilling and production units and other marine structures and systems, "List of ABS Notations and Symbols" is available from the ABS website "<http://www.eagle.org>".

The following notations are specific to floating offshore liquefied gas terminals.

5.1 Class Notations

Floating offshore liquefied gas terminals that have been built, installed and commissioned to the satisfaction of the ABS Surveyors to the full requirements of this Guide, where approved by the Committee for service for the specified design environmental conditions, may be classed and distinguished

in the ABS *Record* by the symbol **⊠ A1**, followed by **Offshore Liquefied Gas Terminal** and the appropriate notation for the intended service listed below.

Class notations were chosen to provide a clear description of the function of each configuration using the following symbols:

- F** Floating
- L** Liquefaction Facility
- O** Transfer of Liquefied Gas (Offloading/Loading)
- P** Gas Processing Facility
- R** Re-Gasification Facility
- S** Storage Facility
- T** Terminal with processing facilities which are not classed

A complete description of applicable class notations for floating liquefied gas terminals is provided in 2-1/1.1 of this Guide.

5.3 Geographical Limitations

Floating offshore liquefied gas terminals which have been built to the satisfaction of the ABS Surveyors to special modified requirements for a limited service, where approved by the Committee for that particular service, may be classed and distinguished in the *Record* by suitable symbols or notations, but the symbols or notations will either be followed by or have included in them the appropriate service limitation.

5.5 Floating Terminals Not Built Under Survey

The symbol "⊠" (Maltese-Cross) signifies that the system was built, installed and commissioned to the satisfaction of the ABS Surveyors. Floating offshore liquefied gas terminals and their equipment that have not been built under ABS survey, but which are submitted for Classification, will be subjected to special consideration. Where found satisfactory and thereafter approved by the Committee, they may be classed and distinguished in the *Record* by the notation described above, but the symbol "⊠" signifying survey during construction will be omitted.

7 Rules for Classification

7.1 Application of Rules

This Guide contains provisions for the classification of new build floating offshore liquefied gas terminals. This Guide is intended for use in conjunction with the *ABS Rules for Building and Classing Marine Vessels (Marine Vessel Rules)*, *ABS Rules for Building and Classing Mobile Offshore Units (MOU Rules)*, *ABS Rules for Building and Classing Offshore Installations*, *ABS Rules for Building and Classing Floating Production Installations (FPI Rules)* or other applicable ABS Rules and Guides.

7.3 Scope of Class

A description of the parts of a floating offshore liquefied gas terminal included in the ABS classification is provided in 2-1/1 of this Guide.

7.5 Alternatives

Any departure from the requirements of this Guide may be considered by ABS on the basis of an additional risk assessment to that required per 2-2/5 of this Guide, or at least a separate, clearly identified part of the risk assessment. In the case of such departures, classification is subject to ABS's approval upon a demonstration of fitness for purpose in line with the principles of ABS Guides and Rules, as well as

recognized and generally accepted good engineering practice. Risk acceptance criteria are to be developed in line with the principles of the ABS Rules and are subject to ABS's approval. The *ABS Guidance Notes on Risk Assessment Applications for the Marine and Offshore Industries* contain an overview of risk assessment techniques and additional information.

A risk approach justification of alternatives may be applicable either to the terminal as a whole or to individual systems, subsystems or components. As appropriate, account must be given to remote hazards outside of the bounds of the system under consideration. Such account must include incidents relating to remote hazards directly affecting or being influenced by the system under consideration. ABS will consider the application of risk-based techniques in the design of the terminal, verification surveys during construction and surveys for maintenance of class.

Portions of the terminal not included in the risk assessment are to comply with the applicable parts of the ABS Rules.

The following are the responsibility of the Owner/Operator:

- i) Risk acceptance criteria
- ii) Hazard identification
- iii) Risk assessment
- iv) Risk management
- v) Compliance of the system under consideration with the applicable requirements of Flag and Coastal State

9 Units

This Guide is written in three systems of units, viz., SI units, MKS units and US customary units. Each system is to be used independently of any other system.

Unless indicated otherwise, the format of presentation in this Guide of the three systems of units, is as follows:

SI units (MKS units, US customary units)

11 Abbreviations and References

11.1 Abbreviations

ABS	American Bureau of Shipping
ACI	American Concrete Institute
AISC	American Institute of Steel Construction
ANSI	American National Standards Institute
API	American Petroleum Institute
ASTM	American Society for Testing and Materials
ASME	American Society of Mechanical Engineers
AWS	American Welding Society
CSA	Canadian Standards Association
FIP	Federation Internationale de la Precontrainte
IMO	International Maritime Organization

NACE	National Association of Corrosion Engineers
NFPA	National Fire Protection Association
PCI	Prestressed Concrete Institute
SIGTTO	Society of International Gas Tanker and Terminal Operators Ltd.

11.3 References

- i) *Marine Vessel Rules - ABS Rules for Building and Classing Marine Vessels*
- ii) *MOU Rules - ABS Rules for Building and Classing Mobile Offshore Units*
- iii) *M/W Rules - ABS Rules for Materials and Welding - Part 2*
- iv) *Offshore Installations Rules - ABS Rules for Building and Classing Offshore Installations*
- v) *SPM Rules - ABS Rules for Building and classing Single Point Moorings*
- vi) *FPI Rules - ABS Rules for Building and Classing Floating Production Installations*
- vii) *Facilities Rules - ABS Rules for Building and Classing Facilities on Offshore Installations*
- viii) *LGC Guide - ABS Guide for Building and Classing Liquefied Gas Carriers with Independent Tanks*
- ix) *ABS Guide for Automatic or Remote Control and Monitoring for Machinery and Systems (other than Propulsion) on Offshore Installations*
- x) *ABS Guide for the Fatigue Assessment of Offshore Structures*
- xi) *ABS Guide for Nondestructive Inspection of Hull Welds*
- xii) *ABS Guidance Notes on Risk Assessment Applications for the Marine and Offshore Industries*
- xiii) *ABS Guidance Notes on Review and Approval of Novel Concepts*
- xiv) *ABS Guide for Surveys Using Risk Based Inspection for the Offshore Industry*
- xv) *ABS Guide for Surveys Based on Machinery Reliability and Maintenance Techniques*
- xvi) *ACI 213R Guide for Structural Lightweight Aggregate Concrete*
- xvii) *ACI 301 Specifications for Structural Concrete*
- xviii) *ACI 311.4R Guide for Concrete Inspection Programs*
- xix) *ACI 318 Building Code Requirements for Structural Concrete*
- xx) *ACI 357R-84 Guide for the Design and Construction of Fixed Offshore Concrete Structures*
- xxi) *ACI 357.2R-88 State-of-the-Art Report on Barge-Like Concrete Structures*
- xxii) *AISC Manual of Steel Construction, ASD*
- xxiii) *API RP 2A, RP 2T, RP 14C, RP 500, RP 521, 620, RP 2003*
- xxiv) *ASTM 330 Specification for Lightweight Aggregates for Structural Concrete*
- xxv) *CSA S474-94 Concrete Structures (Offshore Structures)*
- xxvi) *NACE RP0176-94*
- xxvii) *NFPA 59 A Standard for Production, Storage and Handling of Liquefied Natural Gas*

Note:

The requirements of the IMO "International Code for the Construction and Equipment of Ships Carrying Liquefied Gases in Bulk" are incorporated within requirements in Part 5C, Chapter 8 of the *ABS Marine Vessel Rules*.

ABS is prepared to consider other appropriate alternative methods and recognized codes of practice.

CONTENTS

SECTION	1	Classification of Floating Offshore Liquefied Gas Terminals.....	10
	1	ABS Class Symbols and Notations.....	10
	1.1	Class Notations.....	10
	3	Additional Class Notations.....	11
	3.1	Disconnectable System (1 September 2012).....	11
	3.3	Classification of Dynamic Positioning Systems.....	12
	3.5	On-site Operation.....	12
	3.7	Dynamic Loading Approach (1 September 2012).....	12
	3.9	Design Life and Design Fatigue Life (1 September 2012).....	12
	3.11	Spectral Fatigue Analysis Notation (1 September 2012).....	14
	3.13	Hull Construction Monitoring Program.....	14
	3.15	Additional Corrosion Margin (1 September 2012).....	14
	3.17	LNG Carriers with Re-gasification Facilities (1 September 2010).....	14
	5	⊗ AMS Notation.....	15
	7	Notations for Automatic or Remote Control and Monitoring Systems.....	15
	7.1	⊗ ACC and ⊗ ACCU Notations.....	15
	7.3	⊗ AMCC and ⊗ AMCCU Notations.....	15
	9	Temporary Mooring Equipment Symbol “ⓔ”.....	15
	11	Application of Class Notations (1 June 2013).....	15
	13	Plans and Data to be Submitted.....	18
	13.1	Design Plans and Data for Structures (1 September 2010).....	18
	13.3	Design Plans and Data for Position Mooring Systems....	20
	13.5	Design Plans for Liquefied Gas Containment System, Liquefied Gas and GNG Handling Systems.....	20
	13.7	Design Plans for Process Facilities, Support and Safety Systems.....	22
	13.9	Electrical Installations.....	23
	13.11	Instrumentation and Control Systems.....	23

	13.13	Fire Protection and Personnel Safety.....	23
	13.15	Procedures.....	24
15		Loading Manual (Operating Manual).....	24
17		Trim and Stability Booklet (Operating Manual).....	24
19		Stability	25
21		Lightweight Data.....	25
23		Load Line.....	25

TABLE 1		Floating Terminal Configuration.....	16
---------	--	--------------------------------------	----

TABLE 2		F(LNG)T Notation (<i>1 June 2013</i>).....	17
---------	--	--	----

SECTION 2 Design of Floating Offshore Liquefied Gas Terminals..... 26

1		Environmental Conditions (<i>1 September 2012</i>).....	26
	1.1	Position Mooring.....	26
	1.3	Structural Strength and Fatigue Life.....	28
3		Design Basis.....	29
5		Risk Assessment.....	29
7		Structure - Floating Terminal.....	30
	7.1	Floating Steel Terminals.....	30
	7.3	Floating Concrete Terminals.....	35
9		Containment Systems.....	35
	9.1	Design Features.....	35
	9.3	Design Loads.....	35
	9.5	Steel Terminals.....	36
	9.7	Concrete Terminals.....	36
	9.9	Condensate Storage (<i>2015</i>).....	36
11		Process Facilities.....	36
	11.1	Process Safety Criteria.....	37
	11.3	Gas Processing.....	38
	11.5	Liquefaction.....	38
	11.7	Re-gasification.....	39
	11.9	Import Systems.....	39
	11.11	Export Systems.....	39
	11.13	Risers and Flow Lines.....	39
13		Arrangements.....	39
	13.1	Referenced Rules, Guides and Documents.....	39
	13.3	General Arrangement.....	40
	13.5	Storage Tank Locations.....	41
	13.7	Bow or Stern Loading.....	41
	13.9	Location and Insulation of Accommodation Spaces and Living Quarters.....	41
15		Hazardous Areas (<i>2015</i>).....	41
17		Process Support and Service Systems.....	42

19	Electrical Systems and Installations.....	42
21	Instrumentation and Control Systems.....	43
23	Safety Systems.....	43
	23.1 General.....	43
	23.3 Gas Detection Systems.....	44
	23.5 Fire Detection Systems.....	45
	23.7 Fire Extinguishing and Water Spray (Deluge) Systems...	45
	23.9 Structural Fire Protection.....	45
	23.11 Personnel Protection and Life Saving Appliances.....	45
	23.13 Means of Escape.....	45
	23.15 Emergency Shutdown Systems.....	46
25	Other Systems.....	46

CHAPTER 2 Design Considerations

SECTION 1

Classification of Floating Offshore Liquefied Gas Terminals

In addition to all of the requirements contained in the ABS Rules for Conditions of Classification - Offshore Units and Structures (Part 1) and Chapter 1 of this Guide, the following requirements are applicable to floating offshore liquefied gas terminals.

1 ABS Class Symbols and Notations

1.1 Class Notations (1 August 2023)

Floating offshore liquefied gas terminals (FLGT) that have been built, installed and commissioned to the satisfaction of the ABS Surveyors to the full requirements of this Guide, where approved by the Committee for service for the specified design environmental conditions, may be classed and distinguished in the *ABS Record* by the symbol **⊗ A1**, followed by **Offshore Liquefied Gas Terminal** and the appropriate notation for the intended service listed below:

Class notations were chosen to provide a clear description of the function of each configuration using the following symbols:

- F** Floating
- L** Liquefaction Facility
- O** Transfer of Liquefied Gas (Offloading/Loading)
- P** Gas Processing Facility
- R** Re-Gasification Facility
- S** Storage Facility

Where a floating terminal is fitted with processing facilities, but classification of the entire processing facilities is not desired, certain essential safety systems and equipment for the processing facilities as indicated in 2-2/11 of this Guide are to be in compliance with requirements of ABS. The floating terminal will be classed and distinguished in the *ABS Record* by the symbol **⊗ A1** followed by **Offshore Liquefied Gas Terminal** and the notation **T**. Compliance with the applicable requirements for the floating terminal, position mooring system and import/export systems is required. In addition the shipboard systems, including the electrical system circuit protection for the production facilities and associated fire fighting equipment, are to be reviewed by ABS for the classification of the floating terminal.

For floating terminals designed for LNG, the class notations are:

F(LNG) PLSO - Floating LNG Terminals with Gas Processing and Production, Liquefaction, Storage and Offloading - The floating terminal receives well gas, processes it, liquefies the natural gas and condensate for storage and offloading.

F(LNG) ORS - Floating LNG Storage Terminals with Re-Gasification Facility - The terminal receives LNG from a trading LNG carrier, stores it, re-gasifies and discharges the gas ashore.

F(LNG) SO - Floating LNG Storage and Offloading Terminals - The terminal receives, stores and offloads LNG in a lightering operation.

F(LNG) T - Floating LNG Terminals with Gas Processing and Production, Liquefaction, Storage and Offloading - The terminal receives well gas, processes it, liquefies the natural gas and condensate for storage and offloading. The gas processing, production and liquefaction facilities are not desired to be within the scope of class. However the essential safety features of these facilities are to comply with ABS requirements.

For floating terminals designed for LPG or combined LNG/LPG, the class notations are, respectively:

F(LPG) PLSO, F(LPG) ORS, F(LPG) SO, and F(LPG) T

F(LNG/LPG) PLSO, F(LNG/LPG) ORS, F(LNG/LPG) SO, and F(LNG/LPG) T

For a ship-type installation with **F(LNG)T** notation, the topside module structures may be excluded from the scope of class subject to submission and review of a risk assessment (see 2-2/5) addressing the risk to the safety of the crew, environment, and the vessel due to failure of any topside structure supporting equipment and/or piping containing cryogenic fluid. The hull interface structure is to comply with Section 3-7. See also 2-2/7.1.4(c).

Power generation to be used as main power of the unit for the marine system and safety system is to meet 4-8-2/3.1.1 of the *Marine Vessel Rules* including the support structure. Main power module structure is to comply with 3-7/11 of this Guide for topside structures.

When requested by the Owner, an optional notation **Topside Modules** is available for a ship-type Installation when topside modules comply with 3-7/11. The notation for a ship-type **F(LNG)T** will be appended as, **F(LNG)T (Topside Modules)**.

For floating terminals designed for liquefied gases other than LNG or LPG, the class notations will indicate in parentheses the specific product.

3 Additional Class Notations

3.1 Disconnectable System (1 September 2012)

A floating terminal that has a propulsion system and a means of disengaging the terminal from its mooring and riser systems to allow the floating terminal to ride out severe weather or seek refuge under its own power for a specified design environmental condition will be classed with the appropriate class notation in 2-1/1.1 above and with the notations **(Disconnectable)**, **⊗ AMS** at the end. One example of such class designation is:

⊗ A1, Offshore Liquefied Gas Terminal, F(LNG) ORS (Disconnectable), ⊗ AMS

If a Disconnectable floating terminal is restricted to a specific service area in proximity to its operating site location, a restricted service notation **Disconnectable-R (from site to designated port) or (from**

site to geographic area bounded by Lat. X1, Long. Y1; Lat. X2, Long. Y2; Lat. X3, Long. Y3; Lat. X4, Long. Y4), may be assigned where permitted by local authorities or regulations.

3.3 Classification of Dynamic Positioning Systems

Dynamic positioning systems installed for station keeping purposes, will be denoted by the notation **⊗ DPS** (see Section 2 of the *ABS Guide for Dynamic Positioning Systems*).

3.5 On-site Operation

Floating terminals designed and built to the special modified requirements for on-site operation, where approved by the Committee for that particular service, will be identified in the *Record* by the added notation **(S years)** followed by the approved site of operation, thus **F(LNG) PLSO (S100) Gulf of Mexico**, where "100" signifies that the terminal is reviewed for 100 years design return period.

3.7 Dynamic Loading Approach (1 September 2012)

Where requested, the ABS Dynamic Loading Approach and notation **DLA** may be applied to assess the adequacy of the floating steel structure of liquefied gas terminals. In such cases, the floating terminal will be classed and distinguished in the *Record* by the notation **DLA**. The **DLA** notation will be placed after the appropriate hull classification notation. The application of the dynamic loading approach is optional.

The dynamic load components considered in the evaluation of the hull structure are to include the external hydrodynamic pressure loads, internal dynamic loads (fluids stored onboard, ballast, major equipment items, etc.) and inertial loads of the hull structure. The magnitude of the load components and their combinations are to be determined from appropriate ship motion response calculations for loading conditions that represent the envelope of maximum dynamically-induced stresses in the floating terminal. The adequacy of the hull structure for all combinations of the dynamic loadings is to be evaluated using an acceptable finite element analysis method. In no case are the structural scantlings to be less than those obtained from other requirements in this Guide. In addition, the design of the containment system of independent tanks is to be assessed and analyzed in accordance with Part 5C, Chapter 8 of the *Marine Vessel Rules*.

The basic notation **DLA** is applied when the hydrodynamic loads have been determined using the wave environment of the North Atlantic with a 20-year service life. If the wave environment of the intended site is used during the analysis, the notation will include an **S** qualifier, followed by the design return period at the defined site. For example, if the 100-year return period was used, the following may apply: **DLA (S100)**. Transit conditions to the intended site are also to be included in the DLA evaluation.

3.9 Design Life and Design Fatigue Life (1 September 2012)

3.9.1 Design Life

Floating terminals designed and built to the requirements in this Guide and maintained in accordance with the applicable ABS requirements are intended to have a structural design life of not less than 20 years for a new build hull structure. Where the structural design life is greater than 20 years and the floating terminal is designed for uninterrupted operation on-site without any drydocking, the nominal design corrosion values (NDCV) of the hull structure are to be increased in accordance with 3-2/3.3. When the design life is greater than 20 years (in 5-year increments) the increased life will be identified in the *Record* by the notation **HL (number of years)**. The **(number of years)** refers to the design life greater than 20 years as reflected by the increase in nominal design corrosion values.

3.9.2 Design Fatigue Life (1 July 2022)

Where a floating terminal's design calls for a minimum design fatigue life of 20 years or in excess of the minimum design life of 20 years, the design fatigue life is to be verified to be in compliance with the fatigue criteria in this Guide. The "design fatigue life" refers to the target value set by the owner or designer, not the value calculated in the analysis.

The required fatigue strength analysis of critical details and welded joints in floating terminals is to be in accordance with 3-5/7.1 and 3-5/7.3, and Appendix 3-A1.

Design fatigue life notation is to be assigned and published in the *Record* for the hull, hull interface structure, position mooring system and components. The hull interface structural requirements are described in Section 3-7 of this Guide and the position mooring system requirements in Part 6 of the *FPI Rules*. When only the required fatigue analysis of and 3-5/7.3 is performed, the class notation **FL (number of years)** and the **Year** of maturation of fatigue life in the defined site location is assigned. The fatigue life will be identified in the *Record* by the notation **FL (number of years), Year**; for example, **FL(30), 2041** for a floating terminal built in 2011 if the minimum design fatigue life specified is 30 years.

If in addition spectral fatigue analysis (see 2-1/3.11 and 3-5/7.5) is requested by the owner or designer, only the design fatigue life notation, **SFA (number of years), Year** will be assigned and published in the *Record* for the hull and hull interface structural system. Although only the **SFA** notation is assigned, and not the **FL** notation, the required fatigue analysis of 3-5/7.1 and 3-5/7.3 and Appendix 3-A1 is to be performed and the calculated fatigue life is to satisfy the design fatigue life.

Where different design fatigue life values are specified for structural elements (hull and hull interface structures) and the position mooring system within the installation, the notation **FL (number of years), Year** will be followed by the notation **FLM (number of years), Year**, where "**(number of years)**" refers to the design fatigue life for the position mooring system and "**Year**" refers to the year of maturation associated with the position mooring system.

The **(number of years)** refers to the design fatigue life equal to 20 years or more (in 5-year increments), as specified by the owner or designer. In the case when spectral fatigue analysis is also applied the least of the fatigue life values calculated by the required fatigue strength analysis according to 3-5/7.1 and 3-5/7.3 and spectral fatigue analysis must satisfy the design fatigue life.

For example if the design fatigue life is specified as 25 years, the fatigue calculations of hull structural components must satisfy a fatigue life of 25 years. The fatigue calculations of the position mooring hull interface structures and hull mounted equipment interface structures, and position mooring system must also satisfy fatigue lives of (25 x FDF) years, where FDF are the fatigue safety factors specified in 3-7/9.5.1 TABLE 1 for hull interface structures and in 3/7.7 TABLE 3 and 3/7.7 TABLE 4 of the *ABS Requirements for Position Mooring Systems*.

3.9.3 Conversion of Existing Vessel to FLGT (1 December 2021)

When an existing vessel is converted to an FLGT, the expected minimum remaining fatigue life of the structure is to be assessed according to Section 5A-2-3 of the *ABS Rules for Building and Classing Floating Production Installations* and documented by recording its value in the ABS Record. The **RFL** notation will be followed by the value of the expected minimum remaining fatigue life in years, and the year of maturation of fatigue life.

Where different design fatigue life values are specified for structural elements (hull and hull interface structures) and the position mooring system within the installation, the notation **RFL(number of years), Year** will be followed by the notation **FLM(number of years), Year**, where "**(number of years)**" refers to the target value of the fatigue life for a new position mooring system and "**Year**" refers to the year of maturation associated with the new position mooring system. Where an existing mooring system is to be reused, the notation **RFLM(number of years), Year** referring to the remaining fatigue life of the existing position mooring system will apply. The existing mooring systems covered by the notation **RFLM** are limited to all off-the-vessel mooring components, anchor foundation systems, and submerged buoy structure for disconnectable mooring systems. If any of those components has a fatigue life greater than the mooring system indicated in the notation **RFLM**, this may be noted in the ABS Record. On-the-

vessel mooring components and equipment are to have a design fatigue life equal or greater than the structural elements. If the on-the-vessel components fatigue life exceeds the structural elements, this may also be noted in the ABS Record.

3.11 Spectral Fatigue Analysis Notation (1 September 2012)

The fatigue strength criteria require the fatigue strength evaluation of structural details, which might also rely on spectral analysis methods to demonstrate the adequacy of fatigue strength. Where Spectral Fatigue Analysis is performed in accordance with the ABS *Guide for the Fatigue Assessment of Offshore Structures*, the floating terminal will be identified in the Record by the notation **SFA (number of years)** followed by the specific site of the terminal. The **(number of years)** refers to the design fatigue life equal to 20 years or more (in 5-year increments), as specified by the applicant (e.g., **SFA (30)**). Only one minimum design fatigue life value is applied to the entire structural system as described in 2-1/3.9. This notation is optional.

3.13 Hull Construction Monitoring Program

Floating Liquefied Gas Terminals designed and reviewed to the *FLGT Guide* are to comply with the requirements of the Offshore Hull Construction Monitoring Program in Appendix 3-A6 of this Guide and have the notation **OHCM**.

3.15 Additional Corrosion Margin (1 September 2012)

Where the floating terminal incorporates additional plate thicknesses above the required scantlings, the terminal will be identified in the *Record* by the notation **AT**, followed by the description of the major hull girder component(s) that has the additional thickness. This notation will also include a number to indicate the magnitude of the additional thickness (rounded down to the nearest 0.5 mm) that has been applied (i.e., **AT(DK+0.5)**). In order to apply the notation **AT**, the additional thickness must be applied to the complete structural element throughout the tank area of the floating terminal. This notation documents major areas of the structure that have an additional “as-built” margin on thickness to address areas subject to significant corrosion or areas where it may be desirable to increase normal corrosion margins to extend a structural member’s anticipated service life. This notation is optional and is only available to new construction FLGTs.

The major structural components are defined as follows:

- DK Upper deck
- ID Inner deck
- SD Second deck
- BS Bottom shell (including bilge)
- IB Inner-bottom
- BG Watertight bottom girder
- SS Side shell (including shear strake)
- ST Watertight side stringer
- IS Inner skin (including “hopper” sloping plating)
- CB Centerline cofferdam bulkhead
- TB Transverse Bulkhead

3.17 LNG Carriers with Re-gasification Facilities (1 September 2010)

In some cases, an Owner may elect to install a re-gasification facility on a new or existing trading LNG carrier so that the vessel may load and transport LNG and then re-gasify for direct discharge ashore. When

such a facility is installed on an ABS-classed LNG carrier, the re-gasification facilities may be eligible for ABS certification which will be denoted with the additional notation **(LNG) R** – Re-gasification Facility, so that the class notation as it appears in the *Record* will be:

⊗ **A1 Liquefied Gas Carrier, (LNG) R**

5 ⊗ **AMS Notation**

Machinery and boilers for self-propulsion that have been constructed and installed to the satisfaction of the ABS Surveyors to ABS's Rule requirements, when found satisfactory after trial and approved by the Committee, will be classed and distinguished in the *Record* by the notation ⊗ **AMS**. This notation is mandatory for classification of self-propelled floating terminals built under ABS survey, classed and distinguished in the *Record* by the symbol ⊗ **A1**.

7 **Notations for Automatic or Remote Control and Monitoring Systems**

7.1 ⊗ **ACC and ⊗ ACCU Notations**

For automatic or remote control and monitoring systems of the propulsion machinery, ABS will consider additional classifications with symbols ⊗ **ACC** or ⊗ **ACCU**, as appropriate, provided that the applicable requirements of Part 4, Chapter 9 of the *Marine Vessel Rules* are satisfied .

7.3 ⊗ **AMCC and ⊗ AMCCU Notations**

For automatic or remote control and monitoring systems of the machinery other than the propulsion machinery as referenced in 1/1 of the *ABS Guide for Remote Control and Monitoring for Auxiliary Machinery and Systems (other than Propulsion) on Offshore Installations*, ABS will consider additional classifications with symbols ⊗ **AMCC** or ⊗ **AMCCU**, as appropriate, provided that the applicable requirements of the *ABS Guide for Remote Control and Monitoring for Auxiliary Machinery and Systems (other than Propulsion) on Offshore Installations* are satisfied.

9 **Temporary Mooring Equipment Symbol “ⓔ”**

When requested by the Owner, for self-propelled floating terminals, the symbol ⓔ may be placed after the symbols of classification in the *Record*, thus ⊗ **A1 ⓔ**, which will signify that the equipment for temporary mooring is in compliance with 3-4-1/3 of the *MOU Rules* or Part 3, Chapter 5 of the *Marine Vessel Rules*.

11 **Application of Class Notations (1 June 2013)**

Classification boundaries encompass the floating terminal, position mooring system, import/export systems (see 2-2/11.9 and 2-2/11.11 of this Guide) and may include the processing facilities.

The class notations described above cover the following components:

- i) Floating offshore liquefied gas terminal, including the terminal's hull structure, stability, equipment, marine machinery and all electrical systems under one of the notations in 2-1/1 to 2-1/7 of this Guide, subject to the requirements of this Guide
- ii) Position mooring systems according to the requirements of the *FPI Rules*
- iii) Gas processing, production and liquefaction facilities according to the requirements of this Guide and the applicable sections of the *Facilities Rules*
- iv) Liquefied gas storage facilities (Containment Systems) in accordance with the requirements of this Guide and the applicable sections of Part 5C, Chapter 8 of the *Marine Vessel Rules*
- v) Inlet and outlet facilities in accordance with the requirements of this Guide

- vi) LNG and GNG (Gaseous Natural Gas/LNG vapor) handling systems in accordance with the requirements of this Guide and the applicable sections of Part 5C, Chapter 8 of the *Marine Vessel Rules*
- vii) Re-gasification facilities in accordance with the requirements of this Guide
- viii) Safety systems in accordance with the requirements of this Guide
- ix) Helicopter landing area in accordance with the requirements of this Guide and the applicable sections of the *Marine Vessel Rules* and *FPI Rules*
- x) Dynamic positioning systems where installed in accordance with the applicable section of the *Marine Vessel Rules*
- xi) Superstructure and deckhouse structure
- xii) Appurtenant structures, including lifeboat platforms and crane pedestals and foundations

A floating offshore liquefied gas terminal that is classed to the following notations includes the following elements:

TABLE 1
Floating Terminal Configuration (1 August 2023)

	<i>Structure</i>	<i>Storage</i>	<i>Gas Processing</i>	<i>Liquefaction</i>	<i>Gasification</i>	<i>Position Mooring</i>	<i>Import Systems</i>	<i>Export Systems</i>	<i>Risers and Flow Lines</i>	<i>Min. System Compliance Required</i>
F (LNG) PLSO	X	X	X	X	-	X	X	X	Optional	X
F (LNG) ORS	X	X	-	-	X	X	X	X	Optional	X
F (LNG) SO	X	X	-	-	-	X	X	X	Optional	X
F (LNG) T	X ⁽¹⁾	X	-	-	-	X	-	X	-	X

Notes:

- P** = Process
- L** = Liquefaction
- S** = Storage
- O** = Transfer of Liquefied Gas (Offloading/Loading)
- R** = Re-gasification
- T** = Terminal with processing facilities which are not classed

1. Refer to 2-1/1.1 and 2-2/5.

As noted in 2-1/1.1, for **F(LNG)T** notation, the gas processing, production and liquefaction facilities are not within the scope of class. However, the essential safety features of these facilities are to comply with the ABS requirements. The essential safety features to be addressed are outlined in 2-1/11 TABLE 2 below.

TABLE 2
F(LNG)T Notation (1 June 2013)

<i>System/Equipment</i>	<i>FLGT Guide ⁽¹⁾</i>
Facilities Layout	2-2/13
Area Classification	2-2/15
Export System (Cargo discharge system including loading arms)	2-2/11.11
Means to handled leaked LNG cargo in the event of failure of the primary barrier of any one cargo tank for containment systems required to have a secondary barrier.	2-2/9.1, Note 2
Means to inert containment system , insulation systems and offloading systems	2-2/9 and 2-2/11.11
Means for handling natural boil-off from containment system and excess vapor return from the cargo discharge operations	2-2/9 and 2-2/11.11, Note 3
Electrical System Circuit Protection	2-2/19
Electrical power supply, including generators and their prime movers and associated switchgear for all marine, safety systems and cargo discharge operations.	2-2/19
Electrical Installations in Classified Areas	2-2/15, 2-2/19
Fire Water Systems	2-2/23.7
Dry Chemical Systems, as applicable	2-2/23.7
Fixed Fire Extinguishing Systems	2-2/23.7
Paint Lockers, Laboratory Spaces, and Flammable Material Store Rooms	2-2/23.7
Emergency Control Station	2-2/23.7, 2-2/23.15
Operation After Facility Total Shutdown	Note 4
Portable and Semi-portable Extinguishers	2-2/23.7
Gas and Fire Detection Systems	2-2/23.3, 2-2/23.5
Structural Fire Protection	2-2/23.9, 2-2/13.9
Muster Areas	Note 5
Means of Escape	2-2/23.13
Lifesaving Requirements	2-2/23.11
Personnel Safety Equipment and Safety Measures	2-2/23.11
Process System Description	2-1/13.7.1, Note 6

Notes:

- 1 ABS *Guide for Building and Classing Floating Offshore Liquefied Gas Terminals (FLGT Guide)*.
- 2 This may include transfer to other tanks provided required volume is available (reserved) or jettison of cargo overboard which would require that temporary equipment is provided onboard to facilitate same or other arrangements.
- 3 The means of handling boil off gas from hull tanks under normal conditions and also during total process shutdown is to be submitted for ABS Engineering review. This may include the flare system or components of the flare system.
- 4 Operation after Facility Total Shutdown to be in accordance with 3-8/5.13 of the *ABS Rules for Building and Classing Facilities on Offshore Installations (Facilities Rules)*.

- 5 Muster Area to be in accordance with 3-8/11 of the *Facilities Rules*.
- 6 Process System Description used as reference only.

13 Plans and Data to be Submitted

(2011) Plans and data to be submitted for design review shall generally be submitted electronically to ABS. However, hard copies will also be accepted. Proceeding paragraphs of this Subsection “Plans and Data to be Submitted” cover submittals for the full variety of Class Notations. The actual extent of plans and data to be submitted depend upon the equipment, machinery and systems installed on the terminal and requested for Classification by the Owner.

13.1 Design Plans and Data for Structures (1 September 2010)

Plans showing the scantlings, arrangements and details of the principal parts of the hull structure of each floating terminal to be built under survey are to be submitted and approved before the work of construction has commenced. These plans are to clearly indicate the scantlings, joint details and welding or other methods of connection. In general, plans are to be submitted that include the following, where applicable:

- General arrangement
- Body plan, lines, offsets, curves of form, inboard and outboard profile
- Wind heeling moment curves or equivalent data
- An arrangement plan of watertight compartmentation
- Diagrams showing the extents to which the watertight and weathertight integrity is intended to be maintained, the location, type, and disposition of watertight and weathertight closures
- Capacity plan and tank sounding tables
- Summary of distributions of weights (fixed, variable, ballast, etc.) for various conditions
- Type, location and quantities of permanent ballast, if any
- Loadings for all decks
- Transverse section showing scantlings
- Longitudinal sections showing scantlings
- Decks, including helicopter deck
- Framing, shell plating, watertight bulkheads and flats, structural bulkheads and flats, tank bulkheads and flats with location of overflows and air pipes
- Pillars, girders, diagonals and struts
- Superstructure and deck houses
- Arrangement and details of watertight doors and hatches
- Foundations for anchoring equipment, industrial equipment, process and process support modules, etc., where attached to hull structure, superstructures or deckhouses
- Mooring turrets and yoke arms, including mechanical details
- Corrosion control arrangements
- Methods and locations for nondestructive testing
- Plans and calculations/analyses for the module structures to support process facilities
- Plans and calculations/analyses for module support structures
- Hull Construction Monitoring Plan

13.1.1 Site Condition Reports

The site condition reports, comprised of the environmental and soil data, are to be submitted. For details, refer to Section 3-2-4 of the *FPI Rules*. The principal purpose of these reports is to demonstrate that site conditions have been evaluated in establishing design criteria. Among the items to be discussed are:

- i) Environmental conditions of waves, winds, currents, tides, water depth, air and sea temperature and ice
- ii) Seabed topography for design of anchoring systems, stability and pertinent geotechnical data
- iii) Seismic conditions

Where appropriate, data established for a previous installation in the vicinity of the installation proposed for classification may be utilized if acceptable in the opinion of ABS.

13.1.2 Design Data and Calculations

Information is to be submitted for the terminal which describes the methods of design, and analysis, which were employed to establish its design. The estimated design service life of a terminal is also to be stated. Information for marine systems such as P & IDs, specifications, etc., is also to be submitted. Where model testing is used as a basis for a design, the applicability of the test results will depend on the demonstration of the adequacy of the methods employed, including enumeration of possible sources of error, limits of applicability and methods of extrapolation to full-scale data. Preferably, procedures should be reviewed and agreed upon before model testing is done.

As required in subsequent sections, calculations are to be submitted to demonstrate the sufficiency of the proposed design. Such calculations are to be presented in a logical and well-referenced fashion employing a consistent system of units. Where the calculations are in the form of computer analysis, the submittal is to provide input and output data with computer generated plots for the structural model. A program description (not listings), user manuals and the results of program verification sample problems may be required to be submitted.

13.1.3 Plans and Specifications

Plans or specifications depicting or describing the arrangements and details of the major items of the terminal are to be submitted for review or approval in a timely manner.

Where deemed appropriate, and when requested by the Owner, a schedule for information submittal and plan approval can be jointly established by the Owner and ABS. This schedule, which ABS will adhere to as far as reasonably possible, is to reflect the construction schedule and the complexity of the terminal as it affects the time required for review of the submitted data.

13.1.4 Information Memorandum

An information memorandum on the floating terminal is to be prepared and submitted to ABS. ABS will review the contents of the memorandum to establish consistency with other data submitted for the purpose of obtaining classification. ABS will not review the contents of the memorandum for their accuracy or the features described in the memorandum for their adequacy.

An information memorandum is to contain, as appropriate to the terminal, the following:

- Site plan indicating the general features at the site and the exact location of the terminal
- Environmental design criteria, including the recurrence interval used to assess environmental phenomena (see 2-2/1.1.1)
- Plans showing the general arrangement of the terminal
- Description of the safety and protective systems provided

- The number of personnel to be normally stationed at the terminal
- Listing of governmental authorities having cognizance over the terminal
- Listing of any novel features
- Brief description of any monitoring proposed for use on the terminal
- Description of transportation and installation procedures

13.3 Design Plans and Data for Position Mooring Systems

The design documentation for the mooring system is to include the following, when applicable:

- Mooring arrangement or pattern
- Details of winching equipment
- Details of anchoring system
- Details of mooring line segments
- Connections at anchors and between mooring line segments
- Details of in-line (spring) buoys
- Details of buoy for Catenary Anchor Leg Mooring (CALM) system
- Details of Single Anchor Leg Mooring (SALM) structures, if appropriate
- Details of Turret System to show turret structure, swivel, turntable and disconnecting device
- Details of yoke (hard or soft) connecting the floating terminal and CALM/SALM structure
- Environmental Report
- Mooring Analysis describing method of load calculations and analysis of dynamic system to determine the mooring line design loads
- Model Test report when the design loads are based on model tests in a wave basin
- Thruster specifications and calculations of a system with dynamic positioning system for thruster forces and power to counteract environmental forces (See Sections 3-2-3 and 3-2-4 of the *FPI Rules*.)

13.5 Design Plans for Liquefied Gas Containment System, Liquefied Gas and GNG Handling Systems

The following plans, calculations and information, as appropriate, are to be submitted in addition to those required by Section 1-1-7 of the *ABS Rules for Conditions of Classification - Offshore Units and Structures (Part 1)*:

- Full particulars of the intended cargo and its properties, including flashpoint, maximum vapor pressure, minimum and maximum temperature and loading and storage procedures
- General arrangement plans of the floating terminal showing the position of the following:
 - i) Liquefied gas containment system, fuel oil, water ballast and other tanks and void spaces
 - ii) Manholes and any other opening of the cargo tanks
 - iii) Doors and other openings in cargo pump and compressor rooms and other gas-dangerous rooms
 - iv) Ventilation ducts of cargo compressor rooms and other “gas-dangerous” spaces
 - v) Door, air-locks, manholes, ducts and other openings for “non-gas-dangerous” spaces which are, however, adjacent to the cargo area, including rooms inside and under the forecastle deck
 - vi) Cargo piping, both liquid and gaseous phases, located under and above deck

- vii) Vent piping and gas-freeing piping and protective devices such as flame screens, etc. fitted at the outlet end of the vents etc.
- viii) Gas-dangerous spaces
 - Plans of the floating terminal structure in way of the cargo tanks, including the installation of attachments, accessories, internal reinforcements, saddles for support and tie-down devices
 - Plans of the structure of the cargo containment system, including the installation of attachments, supports and attachment of accessories. For independent pressure cargo tanks, the standard or Code adopted for the construction and design is to be identified. Detailed construction drawings together with design calculations for the pressure boundary, tank support arrangement and analysis for the load distribution. Anti-collision, chocking arrangement and design calculations.
 - Distribution of the grades and of the types of steel proposed for the structures of the terminal together with the calculation of the temperatures on all of the structures which can be affected by the low temperatures of the cargo
 - Results of direct calculations of the stresses in the floating terminal structure and in the cargo containment system
 - A sloshing analysis to demonstrate that the liquefied gas storage tanks, the containment system and the structure can withstand loads under conditions of partially filled tanks to any level consistent with the operations procedures. The description of analysis tools and supporting documents for the validation of the tools are to be provided.
 - Specifications and plans of the insulation system and calculation of the heat balance
 - Thermal heat analysis determining the liquefied gas boil-off rate from the storage tanks
 - Calculations to show the means provided for handling the boil-off gas from storage tanks without causing overpressurization in the tanks
 - Procedures and calculations of the cooling down, loading and unloading operations
 - Loading and unloading systems, venting systems and gas-freeing systems as well as a schematic diagram of the remote controlled valve system
 - Details and installation of the safety valves and relevant calculations of their relieving capacity
 - Details and installation of the various monitoring and control systems, including the devices for measuring the level of the cargoes in the tanks and the temperatures in the containment system
 - Schematic diagram of the ventilation system indicating the vent pipe sizes and height of the openings above the main deck
 - Schematic diagram of the refrigeration system together with the calculations concerning the refrigerating capacity for a re-liquefaction plant, if provided
 - Details of the electrical equipment installed in the cargo area and of the electrical bonding of the cargo tanks and piping
 - Where fitted, plans and specifications relevant to the use of the cargo as fuel for boilers and internal combustion engines (general installations; schematic diagram of the fuel-gas lines with the indication of all the valves and safety devices; compressors of the fuel gas and relevant engines; fuel-gas heaters and pressure vessels; installation of the burners of the fuel-gas and of the fuel oil; electrical bonding systems).
 - Details of testing procedures of cargo tanks and liquid and vapor systems
 - Diagram of inert-gas system or hold-space environmental control system
 - Diagram of gas-detection system
 - Jettison arrangements, if provided
 - Details of all cargo and vapor handling equipment

- Welding procedure for cargo tanks, liquefied gas and GNG piping systems
- Emergency shutdown arrangements
- Construction details of cargo and booster pumps and compressors, including material specification
- Hazardous areas drawing showing access, openings, vent outlets
- Bilge and ballast arrangement for the cargo area
- Emergency towing arrangement

13.7 Design Plans for Process Facilities, Support and Safety Systems

13.7.1 Process and Re-Gasification Facilities

- The process system description
- Project specification and overall process concept evaluation
- Process flow sheets
- Heat and mass balance
- Equipment layout drawings
- Area classification and ventilation drawings
- Piping and instrument diagrams (P & IDs)
- Safety analysis function evaluation (SAFE) charts
- Shutdown and emergency shutdown system to include a hazard analysis and Failure Modes and Effects Analysis (FMEA) to identify critical components
- Pressure relief and depressurization systems
- Flare and vent systems
- Spill containment, closed and open drain systems
- Process equipment documentation, including calculation showing suitability of all pressurized components in the system to withstand the maximum design pressure that a specific component is likely to encounter in service
- Process piping systems
- Packaged process units
- The monitoring and control system for the entire system pressure regulation and gas dispersion system (to include calculations for sizing of the venting system and the relief valve) radiant heat analysis to demonstrate that the radiant heat intensity at any deck level or location where normal maintenance or operating activity could take place is not exceeding API RP 521 recommendations

13.7.2 Process Support and Service Systems

- Piping and Instrument Diagrams (P&IDs) for each system
- Equipment documentation
- Process support piping specifications
- Specification data sheets for internal combustion engines and turbines
- Specification data sheets for cranes (Optional)
- Marine support systems, as required by the ABS Rules applicable to the type of floating terminals

13.9 Electrical Installations

- Electrical one-line diagrams
- Short-circuit current calculations
- Coordination study
- Specifications and data sheets for generators and motors
- Specifications and data sheets for distribution transformers
- Details of storage batteries
- Details of emergency power source
- Standard details of wiring cable and conduit installation practices
- Switchboards and distribution panel
- Panel board
- Installations in classified areas

13.11 Instrumentation and Control Systems

- General arrangements
- Data sheet
- Schematic drawings - electrical systems
- Schematic drawings - hydraulic and pneumatic systems
- Programmable electronic systems

13.13 Fire Protection and Personnel Safety

- Firewater system
- Water spray (Deluge) systems for deckhouse, superstructure and manifold areas
- Water spray (Deluge) systems for process equipment
- Dry powder system for liquefied gas storage tank area
- Fixed fire extinguishing systems
- Paint lockers and flammable material storerooms
- Emergency control stations
- Portable and semi-portable extinguishers
- Fire and gas detection and alarm systems
- Fire and gas cause and effect chart
- Structural fire protection (which indicates classification of all bulkheads and decks for quarters section, machinery spaces and processing facilities)
- Heating ventilation and air conditioning (HVAC) plan [including air handling unit (AHU)], location, duct layout, duct construction and bulkhead and deck penetration details
- Joiner detail arrangement and structural fire protection material certification
- Guard rails
- Escape routes (may be included on the fire control plan or separate plan)
- Lifesaving appliances and equipment plan (escape routes must be indicated)
- Insulation of hot surfaces

- Fire and explosion hazard analysis
- Due to the varying configurations of the project, some portions of these requirements may not be applicable

13.15 Procedures

Procedures are to be submitted for the following:

- Installation procedures for loading sections of the terminal structure, deck area, process modules decks and topsides
- Installation procedures for carrying out all installation work offshore including foundation preparation platform installation and completion
- Disconnecting Procedure, if applicable
- Drydocking Procedure
- Hook Up Procedures
- Import/Export System
- Installation Procedures
- Startup and Commissioning Procedures
- Survey and Inspection Planning Document

15 Loading Manual (Operating Manual)

A loading manual is to be prepared and submitted for review pertaining to the safe operation of the floating terminal from a strength point of view. This loading manual is to be prepared for the guidance of and use by the personnel responsible for loading/unloading the floating terminal. The manual is to include means for determining the effects of various loaded, transitional and ballasted conditions upon the hull girder bending moment and shear force and is to be furnished to the master of the floating terminal for guidance. In addition, a loading instrument suitable for the intended service is to be installed on the terminal. The check conditions for the loading instrument and other relevant data are to be submitted for review.

An operating manual is required for the marine operation of all floating liquefied gas terminals, containing the information listed in Section 1-1-5 of the *MOU Rules* [Supplement to the *ABS Rules for Conditions of Classification - Offshore Units and Structures (Part 1)*] and 5B-1-4/11 of the *FPI Rules*, as applicable. The aforementioned loading manual may be included in the overall operating manual or issued as a separate document. The loading manual, if issued as a separate document, is to be referenced in the overall operating manual. Further, where **Disconnectable** is requested as an additional classification notation, the operating manual is to include procedures for disconnection and reconnection of the installation to its mooring and riser system. (See 3-4-1/13 and 7-1-5/3 of the *FPI Rules*.)

17 Trim and Stability Booklet (Operating Manual)

In addition to the loading manual, a floating terminal is to be provided with sufficient information to guide the master and other responsible personnel in the safe loading, transfer and discharge of cargo and ballast with respect to the hull's trim and stability. The information is to include various loaded, transitional and ballasted example conditions over the full range of operating drafts together with stability criteria to enable the responsible personnel to evaluate the intact and damage stability of any other proposed condition of loading.

This information may be prepared as a separate trim and stability booklet or may be included in the overall operating manual. If issued as a separate document, the trim and stability booklet is to be referenced in the overall operating manual. In addition to the booklet or section of the operating manual, the stability guidance information also may be incorporated as part of the loading instrument described in 2-1/15. (See

3-2-1/7 and Part 3, Chapter 3, of the *Marine Vessel Rules*, Regulation 10 of the 1966 Load Line Convention, Regulation 25 of MARPOL 73/78.)

19 Stability (1 August 2017)

The intact and damage stability of the installation are to be evaluated in accordance with the requirements of the flag and coastal States. In addition, the requirements of the 1966 Load Line Convention, IMO Code on Intact Stability, IMO MODU Code, IGC Code, and MARPOL 73/78 are to be considered as applicable. In the absence of flag or coastal State requirements, Section 3-3-1 of the *MOU Rules* is to be complied with. See 2-1/17 of this Guide for general requirements pertaining to the makeup and issuance of loading guidance with respect to stability.

21 Lightweight Data

The lightweight and center of gravity are to be determined for floating terminals. An inclining test will be required for the first floating terminal of a series, when as near to completion as practical, to determine accurately the lightweight and position of center of gravity. An inclining test procedure is to be submitted for review prior to the test, which is to be witnessed by an ABS Surveyor.

23 Load Line

Every floating terminal is to have marks that designate the maximum permissible draft to which the terminal may be loaded. Such markings are to be placed at suitable visible locations on the hull or structure to the satisfaction of ABS.

Except where otherwise permitted by the flag and coastal States, load line marks are to be established under the terms of the International Convention of Load Lines, 1966.

The floating terminal's arrangements are to comply with all applicable regulations of the International Convention on Load Lines.

CHAPTER 2 Design Considerations

SECTION 2 Design of Floating Offshore Liquefied Gas Terminals

1 Environmental Conditions (1 September 2012)

The floating terminal is to be designed for load scenarios encountered during transit and site-specific conditions. Site-specific conditions are to include both the Design Environmental Condition and the Design Operating Condition.

1.1 Position Mooring

Unless the terminal is classed with the notation **(Disconnectable)**, **⊠ AMS**, floating terminals are to be capable of remaining on station under the most adverse environmental conditions specified in 2-2/1.1.1 of this Guide through a position mooring system. The position mooring system may be comprised of a conventional anchor mooring system or Single Point Mooring (SPM) systems such as: Catenary Anchor Leg Mooring (CALM), Single Anchor Leg Mooring (SALM), Turret Mooring, etc. The design, fabrication, installation, deployment and testing is to be in compliance with the requirements of this section of the *FLGT Guide* and Part 6 of the *FPI Rules*.

The position mooring system of a floating terminal is to be designed to survive in the Design Environmental Condition and operate in the Design Operating Condition. For a disconnectable mooring system, the limiting condition at which the mooring system is to be disconnected or reconnected is to be specified.

1.1.1 Design Environmental Condition (DEC)

The *Design Environmental Condition (DEC)* is defined as the extreme condition with a specific combination of wind, waves and current for which the system is to be designed.

The DEC is to be one of the following combinations that results in the most severe loading case:

- 100-year waves with associated wind and current.
- 100-year wind with associated waves and current.
- 100-year current with associated waves and wind.

In areas with high current, additional design environmental load cases may need to be considered.

The 100-year waves are normally characterized by a significant wave height with a spectral shape type and a range of associated peak wave periods.

A minimum return period of 100 years for the DEC is required for floating terminals. A minimum return period of 50 years will be specially considered if it is accepted by the coastal state. Any environmental combinations with return periods shorter than that of the DEC which induce larger mooring load responses are also to be used in the design.

For a floating terminal with a **Disconnectable** notation (see 2-1/3.1 of this Guide), the *DISconnecting Environmental Condition (DISEC)* of the mooring system is the limiting extreme environmental condition at which the terminal is to be disconnected from the mooring system. However, the permanent mooring system, i.e., the mooring system alone (without the terminal), is to be designed to withstand an environmental condition based on a 100-year recurrence period. An acceptable monitoring system is to be provided for tracking environmental conditions or mooring line tensions in order to assist in the decision to disconnect the terminal from the mooring system.

In addition to waves, wind and current, the design of the floating terminal may require investigation of the following environmental factors, as appropriate to the type of terminal structure and the terminal's operating site:

- i) Tides and storm surges
- ii) Air and sea temperatures
- iii) Ice and snow
- iv) Marine growth
- v) Seismicity
- vi) Sea ice

Other phenomena, such as tsunamis, submarine slides, seiche, abnormal composition of air and water, air humidity, salinity, ice drift, icebergs, ice scouring, etc., may require investigation depending upon the specific operating site.

The required investigation of seabed and soil conditions is described in Section 3-2-5 of the *Offshore Installations Rules*.

1.1.2 Design Operating Condition (DOC)

The *Design Operating Condition (DOC)* is defined as the limiting environmental condition that would require suspension of normal operations. The return period associated with the DOC shall be the larger of: a) the value as specified by the Operator, or b) one year.

1.1.3 Design Installation Condition (DIC)

The *Design Installation Condition (DIC)* is defined as the limiting environmental condition that would require suspension of terminal operations. Specific limits on environmental conditions affecting safe operation during the installation phases described in Part 3, Chapter 4 of the *FPI Rules* are to be established and documented.

1.1.4 Angular Separation of Wind, Current and Waves

For single point mooring systems, which allow the terminal to weathervane, both collinear and non-collinear directions among wind, current and waves are to be considered. Proper angular separation for the DEC of wind, current and waves is to be determined based on the site-specific environmental study. If this information is not available, the following two angular combinations for non-collinear environments can be considered as a minimum:

- i) Wind and current are collinear and both at 30 degrees to waves.
- ii) Wind at 30 degrees to waves and current at 90 degrees to waves.

For spread mooring systems with limited change in the terminal's heading angles (less than 20 degrees) under design environmental loads, the collinear environments of wind, current and waves, which are generally controlling, can be used in design.

For each design sea state, a long-crested sea without spectral energy spreading in direction is normally considered in the mooring analysis.

1.3 Structural Strength and Fatigue Life

1.3.1 On-Site Location

The site-specific environmental conditions, including both 100-year return period environmental events and wave scatter diagram data of wave height/period joint occurrence distribution, are to be considered for the terminal's hull strength and fatigue life assessment. Fatigue life assessment is also to include the effects of on-site operational loading and unloading cycles. A minimum return period of 100 years for the design response should be used for the DEC criteria per API RP 2T. A minimum return period of 50 years for the structural response may be specially considered, provided that it is accepted by the Coastal State. Different environmental conditions may induce different worst responses on various parts of the hull structure. The wave-induced maximum motion responses and maximum structural load effects may result from different wave periods. Therefore, the following two environmental conditions are to be considered to derive the maximum motion responses and maximum structural load effects. The larger of the two values obtained from i) and ii) is to be considered the maximum response:

- i)* 100-year return period waves characterized by a significant wave height with a range of associated peak wave periods. Both winter storms and tropical cyclones (hurricanes or typhoons), if any, need to be considered.
- ii)* Wave scatter diagram data of wave height/period joint occurrence distribution. The length of time on which the data base for the wave scatter diagram data is constructed is long enough to be a reliable basis for design (preferably at least five years). The occurrence distribution is to be annualized with equal probability of occurrence for each data point. Each data point is to represent a sea state of approximately three hours in a continuous time duration of the database.

For both of the above environmental conditions the following are also to be considered:

- i)* Wave directions of head seas and other directions relative to the terminal's heading, including the effects of wind and current, with proper probability distribution are to be considered, irrespective of the type of mooring system utilized.
- ii)* As appropriate, either long-crested seas or short-crested seas with spreading function are to be considered for various design issues.

1.3.2 Transit

The wind and wave conditions representing the environment for the transit route from the building or outfitting site (or the shipyard where the conversion modifications are made) to the project site and the time of the year are to be determined for the design of a floating terminal. Except for floating terminals that qualify for the **Disconnectable** classification notation, any other transit conditions occurring during the operational life of the floating terminal are to be submitted for review. Prior to commencement of such a voyage, an ABS Surveyor is to attend and survey the terminal to assess its condition.

As a minimum, the wind speed and significant wave height of 10-year return period are to be considered, unless a weather routing plan is to be implemented for the voyage. Seasonal effects on the design environments as appropriate for the proposed transit duration can be considered.

In addition to the check on the terminal's hull strength during transit, special attention is to be paid to items such as crane pedestals and process equipment supports that will be subject to motion-induced loading and/or effects of green water. Motion-induced loads during transit are to be calculated and the superstructures and their supports, which are included in the scope of classification, shall be verified against these loads.

If fitted with an internal turret, special consideration is to be given to bottom slamming to preclude damage to the turret supports and bearings.

1.3.3 Disconnectable Terminals

For Disconnectable floating terminals that are disconnected from its mooring and riser systems due to the occurrence of a limiting extreme environmental condition, the structural strength of the terminal shall comply with unrestricted service (North Atlantic) conditions. However, if the Disconnectable floating terminal is restricted to a specific service area in proximity to its operating site location, reduced design load parameters may be applied with an appropriate limited area of disconnected service notation provided that it is accepted by local authorities or regulations. See 2-1/3.1 for class notation.

1.3.4 Strength and Fatigue Life

Hull strength and fatigue life assessment are calculated according to 2-2/7 of this Guide for a given on-site location and transit route.

3 Design Basis

The design of the unit and the facilities on the installation for gas processing, liquefaction, storage, re-gasification, including importing of raw gas or liquefied gas and exporting of processed gas or liquefied gas, is to be in accordance with the criteria defined in this Guide, including any additional prevention or mitigation safeguards identified in the risk assessment required in 2-2/5 of this Guide.

In addition to the requirements mentioned above, it is also the responsibility of the designer, Owner and operator to comply with any additional requirements that may be imposed by the flag State or the coastal State or any other jurisdictions in the intended area of deployment and operation. This would include requirements for importing and exporting pipelines.

The complete basis for the design is to be stated in the operations manual and is to include the intended location, the envelope of environmental operating conditions and the storage capacities and throughputs of the production/re-gasification systems.

5 Risk Assessment (1 August 2023)

A Risk Assessment shall be carried out to identify significant hazards and accident scenarios that may affect the installation or any part thereof, and consider the benefit of existing or potential risk control options.

The objective of the risk assessment is to identify areas of the design that may require the implementation of risk control measures to reduce identified risk(s) to an acceptable level. For this purpose, a systematic process is to be applied to identify situations where a combination or sequence of events could lead to undesirable consequences such as property damage, personnel safety and environmental damage at an acceptable frequency.

For installations classed with **F(LNG)T** notation, the topside module structures may be excluded from the scope of class subject to submission and review of a risk assessment considering damage to and eventual failure of any topside structure supporting equipment and/or piping containing cryogenic fluid due to the above-mentioned reasons demonstrating the risk to the safety of the crew, environment and hull structure falls within the acceptable risk criteria.

The risk assessment is to consider, as a minimum, the following events:

- i)* Damage to the primary structure and topside structure due to extreme weather, impact/collision, dropped objects, helicopter collision, exposure to unsuitably cold temperatures, exposure to high radiant heat
- ii)* Fire and explosion
- iii)* Loss of primary liquid containment (for a duration to be determined based on an approved contingency plan)
- iv)* Liquefied gas leakage
- v)* Release of flammable or toxic gas to the atmosphere or inside an enclosed space
- vi)* Roll-Over (thermodynamic instability due to liquefied gas stratification)
- vii)* Loss of stability
- viii)* Loss of any single component in the station keeping/mooring system
- ix)* Loss of ability to offload liquefied gas or discharge gas ashore
- x)* Loss of any one critical component in the process system
- xi)* Loss of electrical power

Commentary:

Various risk assessment techniques can be used to identify and address risk. For risk assessment techniques that can be included, refer to the ABS *Guidance Notes on Risk Assessment Applications for the Marine and Offshore Industries* or IEC/ISO 31010 “Risk management – Risk assessment techniques”.

End of Commentary

The identified risk control options (prevention and mitigation measures) deemed necessary to be implemented should be considered part of the design basis of the terminal.

ABS recommends that early in the project a risk assessment plan be developed, documented and submitted to ABS for review prior to conducting the risk assessment. During review of the plan, an agreement will be reached on the extent of ABS participation and/or monitoring of project-related risk studies. ABS’s participation in and/or monitoring of key tasks (e.g., Hazard Identification meetings) is necessary in order to establish a minimum level of confidence on the risk assessment results.

7 Structure - Floating Terminal

Chapter 3 of this Guide and the *FPI Rules*, directly and by reference to other standards, present the criteria deemed most applicable to the structural design of Floating Offshore Liquefied Gas Terminals. Major portions of the structural criteria from these ABS standards are excerpted and modified below to reflect envisioned liquefied gas terminal service. This has been done for the convenience of users and to concisely present in this Guide the main structural design and construction features included in the scope of Classification and the criteria to be applied. Reference should be made to the aforementioned Chapter 3 and *FPI Rules* for additional background on the referenced criteria.

7.1 Floating Steel Terminals

7.1.1 General

7.1.1(a) Basic Principle.

The design and construction of steel floating liquefied gas and/or liquefied gas vapor terminal structures are to be based on the applicable requirements in Chapter 3 of this Guide and the , with

modifications to reflect the service of terminals positioned to a fixed site on a long term basis and cryogenic temperature of the cargo, as indicated in this Guide.

7.1.1(b) Referenced Rules and Guides.

Refer to 1-1/11 of this Guide.

7.1.1(c) Proportion.

The requirements contained in this Guide are applicable to floating offshore liquefied gas terminals, having lengths of 150 meters (492 feet) or more, but not exceeding 500 m (1640 ft) in length, having breadths not exceeding one-fifth of the length nor 2.5 times the depth to the strength deck. Floating terminals beyond these proportions will be reviewed on a case-by-case basis.

7.1.1(d) Types of Tanks.

In this Guide, the following types of tanks are considered:

- Membrane tanks
- Type B (IMO Gas Carrier Code) independent tanks
- Other tanks subject to special consideration

7.1.1(e) Access for Inspection.

In the design of the terminal, consideration should be given to providing access for inspection during construction and, to the extent practicable, for survey after construction.

7.1.1(f) Steel-Concrete Hybrid Structures.

The steel portions of a steel-concrete hybrid structure are to be designed in accordance with the requirements of 2-2/7.1 of this Guide, and the concrete portions are to be designed as specified in 2-2/7.3. Any effects of the hybrid structure interacting on itself in areas such as corrosion protection should be considered.

7.1.1(g) Steel-Concrete Composite Structures.

Steel-concrete composite structures are to be designed in accordance with 2-2/7.1 of this Guide and the AISC, "Allowable Stress Design".

7.1.2 Materials and Welding

7.1.2(a) Material.

This Guide is intended for terminals of welded construction using steels complying with the requirements of Chapter 1 of the *ABS Rules for Materials and Welding (Part 2)* and Section 5C-8-6 of the *Marine Vessel Rules*. Use of materials other than those mentioned and the corresponding scantlings will be specially considered.

7.1.2(b) Selection of Material Grade.

The selection of structural steel material grade for hull and tanks is to be in accordance with 3-1-2/3.1 and 5C-8-4/19 of the *Marine Vessel Rules*. The *ABS Rules for Materials and Welding (Part 2)* is one of the "Recognized Standards" in 5C-8-4/19.1.2 of the *Marine Vessel Rules*.

7.1.2(c) Welding.

The welding is to be in accordance with Section 2-4-1 of the *ABS Rules for Materials and Welding (Part 2)* and 5C-8-4/20 of the *Marine Vessel Rules*.

7.1.3 Survival Capability and Location of Cargo Tanks

Floating terminals are to comply with the survival capability and cargo tank location requirements in Section 5C-8-2 of the *Marine Vessel Rules*.

7.1.4 Structural Analysis

Scantlings of plating, stiffeners and deep supporting members and hull girder strength are first to be determined in accordance with 2-2/7.1.4(a). A total strength assessment of the structure with the scantlings so determined is to be carried out in accordance with 2-2/7.1.4(b). A hull interface structural analysis is to be carried out in accordance with 2-2/7.1.4(c).

7.1.4(a) Initial Hull Scantlings.

The initial thickness of plating, the section modulus of longitudinals/stiffeners, the scantlings of the main supporting structures, and the hull girder strength are to be determined in accordance with the following paragraphs:

- i) *Membrane Tank Terminals.* The initial scantlings are to be in accordance with Section 3-4.
- ii) *Type B Independent Tank Terminals.* The initial scantlings are to be in accordance with Section 3-4 of this Guide and 5C-8-1/11 of the *Marine Vessel Rules*.

7.1.4(b) Total Strength Assessment (1 September 2012).

A total strength assessment of the structure, with scantlings initially selected in accordance with 2-2/7.1.4(a), is to be carried out against three modes of failure, i.e., yielding, buckling/ultimate strength and fatigue, to confirm the adequacy of the structural configuration and initially selected scantlings, as follows:

- i) *Membrane Tank Terminals.* The assessment is to be in accordance with Section 3-5 of this Guide.
- ii) *Type B Independent Tank Terminals.* The assessment is to be in accordance with Section 3-5 of this Guide and 5C-8-1/11 of the *Marine Vessel Rules*.

In addition, an assessment in accordance with the Dynamic Loading Approach (DLA) described in 2-1/3.7 or equivalent may be carried out in conjunction with Spectral Fatigue Analysis (SFA).

7.1.4(c) Hull Interface Structural Analysis.

The hull design will also need to consider the interface between the position mooring system and the hull structure and the interface between deck-mounted (or above-deck) equipment modules and the hull structure. The interface structure is defined as the attachment zone of load transmission between the main hull structure and hull mounted equipment, including the position mooring system. The analysis of the hull interface structure as defined above is to be performed using direct calculation of local 3-D hull interface finite element models as described in Section 3-7.

7.1.5 Fatigue Analysis

7.1.5(a) General.

The fatigue strength of welded joints and details at terminations located in highly stressed areas and in fatigue prone locations are to be assessed, especially where higher strength steel is used, as specified in 2-2/7.1.5(d) of this Guide. These fatigue and/or fracture mechanics analyses, based on the combined effect of loading, material properties and flaw characteristics, are performed to predict the service life of the structure and to determine the most effective inspection plan. Special attention is to be given to structural notches, cut-outs, bracket toes and abrupt changes of structural sections. It is envisaged that liquefied gas terminals will be designed for a minimum fatigue life of twenty (20) years.

7.1.5(b) Design Fatigue Life (1 September 2012).

The minimum design fatigue life is the service life multiplied by the Fatigue Design Factor (*FDF*) for site-specific service floating terminals using the wave spectrum at that site. Impact on fatigue life as a result of tow from fabrication to operating site is to be included in the fatigue assessment.

The design fatigue life will appear in the *Record* as described in 2-1/3.9 of this Guide.

7.1.5(c) Fatigue Design Factor.

FDF is a factor, equal or greater than one (1) that is applied to individual structural details and which accounts for: uncertainties in the fatigue assessment process, the consequences of failure (i.e., criticality), and the relative difficulty of inspection and repair. *ABS Guide for the Fatigue Assessment of Offshore Structures* provides specific information on the values of *FDF*.

7.1.5(d) Process of Fatigue Analysis.

The stress range due to loading and unloading cycles is to be accounted for in the overall fatigue damage assessment, see 3-5/7 and Appendix 3-A1. The cumulated fatigue damage during the transit voyage from the fabrication site to the operation site is to be included in the overall fatigue damage assessment.

- i) Membrane Tank Floating Terminals.* The fatigue analysis is to be in accordance with Appendix 3-A1. In addition, a Spectral Fatigue Analysis may be carried out in accordance with the Spectral Fatigue Procedure for Ship-Shaped FPSOs.
- ii) Type B Independent Tank Floating Terminals.* The fatigue analysis of the hull structure and tank structure are to be in accordance with Appendix 3-A1. The fatigue analysis of the tank supports and chocks shall be in accordance with Appendix 3-A1 using finite element models described in Appendix 3-A5. In addition, a spectral fatigue analysis may be carried out in accordance with the Spectral Fatigue Procedure for Ship-Shaped FPSOs.

7.1.6 Design Loads for Local Structures

Note:

For the purpose of 2-2/7.1.6, "Transit Condition" means that the terminal is either in: a) transit from/to site with own propulsion or with propulsion assistance, or b) on site, but in a disconnectable mode with own propulsion. For the purpose of 2-2/7.1.6, "On-Site Condition" means that the terminal is not in "Transit Condition."

7.1.6(a) Sloshing Loads.

The natural periods of liquid motions and sloshing loads are to be determined and an assessment carried out of the strength of boundary structures of liquid tanks.

- i) Transit Condition.* For membrane tank floating terminals, the sloshing pressure heads given in 3-3/11 and 3-3/13 for membrane tanks and for Type B independent tanks, respectively, may be used for determining the scantlings. Alternatively, sloshing loads may be calculated either by model experiments or numerical simulation using three-dimensional flow analysis for unrestricted service conditions and for sea conditions of the specific site of operation. Methodology and procedures of tests and measurements or analysis methods are to be fully documented and submitted for review.
- ii) On-site Condition.* Sloshing loads are also to be determined for on-site service. 3-3/11 and 3-3/13 for membrane tanks and for Type B independent tanks, respectively, may be referred to.

7.1.6(b) Forebody Strengthening.

Impact loads on the forebody structure are to be determined for transit and on-site conditions. Unless one end is specifically designated as the bow, terminals are to be designed with each end as the bow.

- i) Bottom Slamming*
 - *Transit Condition.* For terminals with heavy weather ballast draft forward equal to or less than $0.04L$ and greater than $0.025L$, the bottom slamming pressures are to be calculated using 3-3/15.3 and the scantlings determined in accordance with 3-6/7.1.

Floating terminals with heavy weather ballast draft forward equal to or less than $0.025L$ will be subject to special consideration.

- *On-site Condition.* For the determination of loads for the on-site condition, refer to 3-3/15.3.

ii) Bowflare Slamming

- *Transit Condition.* For floating terminals having a bowflare shape parameter greater than 21 m in the forebody, bowflare slamming loads are to be calculated in accordance with 3-3/15.5 and the scantlings determined in accordance with 3-6/7.3.
- *On-site Condition.* For the determination of loads for the on-site condition, refer to 3-3/15.5.

iii) Bow Impact Loads

- *Transit Condition.* Where experimental data are not available or direct calculation is not carried out, nominal bow pressures above LWL from the forward end to the collision bulkhead may be obtained from 3-3/15.1.
- *On-site Condition.* For the determination of loads for the on-site condition, refer to 3-3/15.1.

iv) Green Water

- *Transit Condition.* Where experimental data are not available or direct calculation is not carried out, nominal green water pressure on deck from FP to 0.30L aft, including the extension beyond the FP, may be obtained from 5C-3-3/5.5.4(b) of the *Marine Vessel Rules*. Minimum deck scantlings may then be determined using 5C-3-6/9 of the *Marine Vessel Rules*.
- *On-site Condition.* For the determination of loads for the on-site condition, refer to 3-3/15.7.

7.1.6(c) Deck Loads.

Deck loads due to on-deck processing facilities for on-site and transit conditions are referenced in 3-3/17.

7.1.6(d) Terminal Operation.

The expected loads and other demands that will be acting on the floating terminal as a result of the need to berth and moor vessels are to be considered in the design. These may include vessel breasting and mooring loads, the presence of fenders and the additional hydrodynamic and gravity loads that they bring, the need to support bollards and other mooring hardware, etc.

7.1.7 Superstructures, Deckhouses and Helicopter Decks

7.1.7(a) Superstructures and Deckhouses.

The design of superstructures and deckhouses is to comply with the requirements of 3-2-11 of the *Marine Vessel Rules*. The structural arrangement of forecastle decks in 3-2-11/9 of the *Marine Vessel Rules* is to be satisfied, regardless of speed.

7.1.7(b) Helicopter Decks.

The design of the helicopter deck structure is to comply with the requirements of 3-2-2/3 of the *MOU Rules*. In addition to the required loadings defined in 3-2-2/3 of the *MOU Rules*, the structural strength of the helicopter deck and its supporting structures are to be evaluated considering the DOC and DEC environments, if applicable.

7.1.8 Other Structures

Appurtenant structures such as lifeboat platform for life saving, crane pedestal and pipe racks, for example, are to comply with the requirements in 3-2-2/9 of the *MOU Rules*. The design criteria for other hull structures where not addressed in this Guide or the referenced Rules and Guides are to conform to recognized practices acceptable to ABS.

7.3 Floating Concrete Terminals

See 2-2/9.7 for prestressed concrete offshore liquefied gas terminals.

9 Containment Systems

The liquefied gas containment system is a mandatory part of ABS classification of the floating terminal's structure. The liquefied gas containment system is to be in accordance with the requirements of Section 5C-8-4 of the *Marine Vessel Rules* or NFPA 59A.

Alternative arrangements for the containment system, such as the use of a properly designed prestressed concrete structure as a secondary cryogenic barrier, application of membrane lining/barrier systems into concrete containment components, etc., may be given special consideration.

9.1 Design Features

Unless considered otherwise, the design of the containment system should incorporate the following features to satisfy the intent of these Rules and Standard:

- i) A secondary containment system such that if there is a failure in the primary system, the secondary system is to be capable of containing the leaked liquid contents for an agreed period of time consistent with the approved scenarios for the safe disposal of same
- ii) There is to be a minimum of two independent means of determining the liquid level in the liquefied gas storage tanks.
- iii) Means to fill the tank from various elevations within the tank to avoid stratification
- iv) Independent high and high-high level alarms
- v) At least one pressure gauge connected to the vapor space
- vi) Two independent overpressure protection devices
- vii) Devices for measuring the liquid temperature at the top, middle and bottom of tank
- viii) A gas detection system which will alarm high gas concentrations in the space between the primary and the secondary barrier

9.3 Design Loads

Tanks, together with their supports and fixtures, are to be designed with consideration of proper combinations of the following loads:

- i) Internal pressure
- ii) External pressure
- iii) Dynamic loads due to motion of the floating terminal
- iv) Thermal loads
- v) Sloshing loads
- vi) Loads corresponding to hull deflections
- vii) Tank and cargo weight with the corresponding reactions in way of the supports
- viii) Insulation weight

- ix) Loads in way of towers and other attachments

The sloshing loads are to consider any level of filling in each tank unless it can be shown that cargo can be shifted in a timely manner, and the level in the tanks can be maintained within the approved design limits.

The loads in way of supports are also to consider the unit inclined up to the worst angle of inclination resulting from flooding consistent with the unit's agreed-to damage stability criteria up to an angle of 30 degrees.

9.5 Steel Terminals

In the case of floating steel offshore liquefied gas terminals, the requirements of Section 5C-8-4 of the *Marine Vessel Rules* are considered applicable.

9.7 Concrete Terminals

On floating concrete offshore liquefied gas terminals constructed of prestressed concrete, the outer containment system may be constructed of concrete in accordance with the requirements of Section 7.4.3 of NFPA 59A.

9.9 Condensate Storage (2015)

Condensate storage tanks integral with the terminal's hull are to be in compliance with the requirements of Section 5C-1-7 of the *Marine Vessel Rules* and 3-5/5.9 of the *Facilities Rules*. Where condensate may contain dangerous or noxious liquid chemical substances with its content ratio exceeding the threshold values as defined in the "International Code for the Construction and Equipment of Ships Carrying Dangerous Chemicals in Bulk" (IBC Code), the requirements of Chapter 9 of Part 5C of the *Marine Vessel Rules* are to be followed as applicable to the particular substances present. Where the threshold values are not specified, ABS is to be consulted for required clarification.

Condensate storage in tanks adjacent to liquefied gas storage tanks will be considered acceptable, provided it can be shown that loss of primary liquefied gas containment would not cause an underpressure situation or the ingress of air into the condensate tank.

11 Process Facilities

Where process facilities are requested to be within the scope of Class, the facilities installed onboard the terminal for processing raw gas from the well(s) or bringing partially processed gas from another installation, liquefied gas production or liquefaction or re-gasification system for converting liquefied gas into vapor for shipment ashore, the entire installation, including the import and export system, are subject to requirements of this Guide.

For Classification purposes, whichever of the process systems are employed, the facilities are to be in place so that the entire operation can be carried out safely. Accordingly, in order to carry out an assessment of the system, the plans and calculations listed in 2-1/13.7 of this Guide are required to be submitted.

ABS may require additional information depending on the systems used and their configuration.

Where processing facilities are not within the scope of Class, requirements contained in this Guide relating to the safety of the terminal will be considered within the scope of Class. For example, the following systems will be subject to approval by ABS:

- i) Interface to the Fire Extinguishing system
- ii) Hazardous areas
- iii) Gas disposal system (venting and relief)

11.1 Process Safety Criteria

The design of the onboard process facilities described above is to include an overall evaluation of the proposed concept with a view toward reducing the likelihood of the occurrence of the undesirable events identified in 2-2/5 of this Guide.

The ABS evaluation will include a systematic consideration of arrangements, layouts, process systems, process support systems, process controls and safety systems as well as a review of all safety critical equipment. The term “safety critical” is meant to include equipment whose reliable performance is considered essential to maintaining a safe facility as well as equipment whose failure in and of itself could lead to an unsafe occurrence.

While the design of the terminal arrangements, safety systems and systems for handling liquefied gas and liquefied gas vapor on a terminal may rely primarily on the proven practices employed on liquefied gas carriers, it must be recognized that on a liquefied gas carrier, except during cargo loading and discharge operations, there is very little hydrocarbon outside of the containment system. Accordingly, additional provisions may be required depending on the process system installed on the terminal. This may include such items as an extension of the hazardous areas, the need for a gas dispersion analysis and the provision of a means to de-energize electrical systems in the event of a major release of high pressure gas.

Due to the varying quantity and means of handling and storage of the hydrocarbon refrigerants, it must also be recognized that the level of risk associated with natural gas liquefaction is dependent on the liquefaction process selected. Accordingly, wherever possible, the location of these systems should be on open deck.

Similarly, while some liquefied gas carriers are arranged for bow or stern loading and unloading in accordance with the provisions of 5C-8-3/8 and 5C-8-5/10.1 of the *Marine Vessel Rules*, it must be recognized that the existing requirements for liquefied gas carriers do not envisage the increased risk of a liquefied gas or liquefied gas vapor release from the systems and equipment that may be employed in the import and export systems covered under 2-2/11.9 and 2-2/11.11 of this Guide. Accordingly, drip trays are to be provided as necessary, and components such as cryogenic hoses and gas swivels that may be susceptible to leakage should be located on the open deck. Furthermore, the means to provide reliable, adequate ventilation in any enclosed spaces containing portions of the gas transfer system and provisions for gas detection are to be considered and included in the overall risk analysis required in 2-2/5 of this Guide.

The safe disposal by flaring of hydrocarbon gas released due to an overpressure or other upset condition should be taken into consideration in the design of the system. However, the process systems are to be closed systems. Accordingly, continuous flaring is not an acceptable design premise.

The process safety overall criterion is that systems and equipment on an offshore liquefied gas terminal be designed to minimize the risk of hazards to personnel, property and environment. Implementation of this criterion to gas processing, liquefaction or re-gasification facilities and the associated support facilities is intended to:

- i) Prevent an abnormal condition from causing an upset condition
- ii) Prevent an upset condition from causing a release of hydrocarbons or cryogenic fluids
- iii) Safely collect and dispose of hydrocarbon or cryogenic fluids released
- iv) Prevent formation of explosive mixtures
- v) Prevent ignition of flammable liquids or gases and vapors released
- vi) Limit exposure of personnel to fire hazards

11.1.1 System Requirements

The design of process systems and process control systems described above, along with process support systems, depressurization and vent systems, flares and drain systems, is to comply with

the requirements of Section 3-3 of the *Facilities Rules*. In addition, systems that are in direct contact with liquefied gas or liquefied gas vapor are to be designed for compliance with the requirements of Part 5C, Chapter 8 of the *Marine Vessel Rules* and the applicable requirements of NFPA 59A, *Standard for the Production, Storage and Handling of Liquefied Natural Gas (LNG)* 2013. Where there is a conflict between various referenced requirements, ABS is to be consulted for clarification.

The systems and equipment for ship-to-terminal liquefied gas loading or liquefied gas discharge such as special loading arms and/or cryogenic hose, hose cranes, primary emergency release couplings (PERCs), relative motion sensors, emergency shutdown systems and other special arrangements will be considered in each case based on the submitted design justification. The design justification is to include an envelope of limiting operational environments including sea states, wind, current and visibility.

11.1.2 Component Requirements

It is envisaged that a list of major components present on a liquefied gas terminal includes but is not limited to: loading arms, cryogenic hoses, pig receivers, separators, knock-out drums, heat exchangers, packed columns, absorbers, plate fin type heat exchangers, spiral (spool) wound heat exchangers, tube and shell heat exchangers, pumps and compressors with either gas turbine or electric drivers, direct and indirect heaters and vaporizers. These process system components and the associated piping systems that carry hydrocarbon liquids and vapors will be subject to ABS review.

The design, manufacture, testing, certification and installation of process components are to be in compliance with the requirements of 3-3/17 of the *Facilities Rules*. The selection of material of components subject to temperatures below -18°C (0°F) is to comply with the requirements of Section 5C-8-6 of the *Marine Vessel Rules*. Conformance to standards or codes different from those listed therein will be considered, where applicable. Components not covered in the referenced ABS Rules will be considered on the basis of compliance with applicable, acceptable industry standards and the manufacturer's design justification and proof testing. Design justification based on stress analysis should comply with the requirements of the ASME Boiler and Pressure Vessel Code Section VIII Division 2.

11.3 Gas Processing

For the purposes of this Guide, the gas processing facilities are considered to include all systems and components for the reception of raw gas from the well(s) or partially processed gas from another installation on the platform facilities for such processes as acid gas removal, dehydration and mercury removal.

11.5 Liquefaction

For the purpose of this Guide, the Liquefaction Facilities are considered to include all systems and components for pre-cooling, fractionation, main cryogenic refrigeration and storage. There are a number of proven, proprietary liquefaction methodologies available, whichever of these systems is used, and details, as mentioned in 2-2/11.1, are to be submitted.

The subsystems and major items of equipment can vary significantly depending on which liquefaction methodology is employed. Accordingly, a description of the system and an operational philosophy adopted is to be submitted in order to evaluate the safety of the entire system.

However, the following is given as a reference to define the scope of Classification:

- i) It is envisaged that the pre-cooling may be done in a propane, nitrogen or mixed refrigerant heat exchanger with the associated refrigerant refrigeration cycle: compressor, condenser, coolers and accumulators. The pre-cooling heat exchanger may be of the spiral wound or plate fin type.

- ii) It is envisaged that the fractionation includes subsystems or plants called de-ethanizers, de-propanizers and de-butanizers. Each plant is comprised of a vertical column type separator, pumps, heat exchangers and accumulators.
- iii) The main cryogenic refrigeration is normally done in either a multi-stage spiral wound heat exchanger or in an assembly of plate fin type heat exchangers called a cold box. In most liquefied gas liquefaction processes, a mixture of hydrocarbons is used as the primary refrigerant and these processes are called MR Processes. However, in the cascade system, propane, ethane, methane, and ethylene are each used at consecutive stages of refrigeration. In the nitrogen system, nitrogen is used as the refrigerant in a compression and expansion process.
- iv) The storage includes both liquefied gas storage and storage of condensate produced from the liquefaction process.

11.7 Re-gasification

For the purposes of this Guide, Re-gasification Facilities are considered to include all systems and components for removing liquefied gas from the storage tanks, pressurizing, heating and vaporizing liquefied gas and in some cases odorizing the liquefied gas vapor and discharge ashore of vaporized gas through an off-loading system. If there are compressors in the discharge system, they would be considered part of the Re-gasification Facility.

11.9 Import Systems

For the purposes of this Guide, Import Systems on load terminals are considered to include the entire gas swivel on turret-moored units and the first onboard flange for units maintained on station through a spread mooring system, plus all onboard gas flow lines up to the gas processing facility.

In the case of discharge terminals, the Import Systems would include the liquid and vapor loading arms and the cryogenic hoses or the cargo manifold, depending on the liquefied gas ship to terminal transfer configuration employed, plus all on deck valves and piping up to the liquid and vapor inlet flanges on the cargo tank domes.

11.11 Export Systems

For the purpose of this Guide, Export Systems on load terminals are considered to include the cargo pumps, stripping pumps, high duty gas compressors, liquefied gas vaporizers and all valves and piping in the liquid discharge and vapor return systems up to and including the cargo manifold, loading arms or cryogenic hoses, depending on the liquefied gas terminal to ship transfer configuration employed.

In the case of discharge terminals, the Export Systems would include the gas flow lines from the re-gasification facility up to and including the entire gas swivel on turret moored units or the last onboard flange on units maintained on station through a spread mooring system.

11.13 Risers and Flow Lines

Rigid and flexible risers connecting flow lines and submerged jumpers are not considered to be within the scope of classification of the terminal. However, at the Owner's request, the import or export risers starting from, but not including the Pipe Line End Manifold (PLEM), may be included in the scope of classification, provided they are found to be in compliance with the requirements of Part 4, Chapter 2 of the *FPI Rules*.

13 Arrangements

13.1 Referenced Rules, Guides and Documents

Refer to 1-1/11 of this Guide.

13.3 General Arrangement

Machinery and equipment are to be arranged in groups or areas in accordance with API RP14J. Equipment items that could become fuel sources in the event of a fire are to be separated from potential ignition sources by space separation, firewalls or protective walls.

Typical fuel sources may be as listed below:

- i)* Gas inlet and departing flow lines
- ii)* Process and Hydrocarbon Refrigerant Piping
- iii)* Risers and Pipelines
- iv)* Vents
- v)* Pig Launchers and Receivers
- vi)* Drains
- vii)* Portable Fuel Tanks
- viii)* Chemical Storage Tanks
- ix)* Laboratory Gas Bottles
- x)* Sample Pots
- xi)* Liquefied Gas manifolds or loading arms
- xii)* Separators and Scrubbers
- xiii)* Coalescers
- xiv)* Gas Compressors
- xv)* Liquid Hydrocarbon Pumps
- xvi)* Heat Exchangers
- xvii)* Hydrocarbon Refrigerant Storage Tanks
- xviii)* Gas Metering Equipment
- xix)* Oil Treaters (unfired vessels)
- xx)* Swivels

Typical ignition sources may be as listed below:

- i)* Fired Vessels
- ii)* Combustion Engines & Gas Turbines
- iii)* Living Quarters
- iv)* Flares
- v)* Welding Machines
- vi)* Grinding Machines
- vii)* Cutting Machinery or Torches
- viii)* Static Electricity
- ix)* Ships
- x)* Electrical Equipment
- xi)* Waste Heat Recovery Equipment

- xii) Mobile phones
- xiii) Lightning
- xiv) Spark Producing Hand Tools
- xv) Portable Computers
- xvi) Cameras
- xvii) Non-Intrinsically Safe Flashlights
- xviii) Helicopters

In case of a fire, the means of escape is to permit the safe evacuation of all occupants to a safe area, even when the structure they occupy can be considered lost in a conflagration. With safety spacing, protective firewalls and equipment groupings, a possible fire from a classified location is not to impede the safe exit of personnel from the danger source to the lifeboat embarkation zone or any place of refuge.

13.5 Storage Tank Locations

The location of storage tanks with respect to the outer boundaries of the structure is to be consistent with the extent of damage assumed in 2-2/5 and 2-2/7.1.3 of this Guide, unless it can be shown through relative motion studies or traffic studies that other arrangements will be not less effective at protecting the storage tanks.

13.7 Bow or Stern Loading

The requirements of 5C-8-3/8 and 5C-8-5/10.1 of the *Marine Vessel Rules* for bow or stern loading arrangements will be considered applicable to import or export systems that run past accommodations or other sources of vapor ignition.

13.9 Location and Insulation of Accommodation Spaces and Living Quarters

Accommodation spaces or living quarters are to be located outside of hazardous areas and may not be located above or below liquefied gas or condensate storage tanks or process areas. "H-60" bulkhead requirements of 3-8/9 and 4-8/9 of the *Facilities Rules* will be applied. If such bulkhead is more than 33 m (100 ft) from this source, then this can be relaxed to an "H-0" rating. As is explained in Section 3-8 of the *Facilities Rules*, "A-60" and "A" rated bulkheads, respectively, may be utilized, provided that a risk or fire load analysis was done and reviewed by ABS, indicating that these bulkheads are acceptable.

15 Hazardous Areas (2015)

The delineation of hazardous areas or gas-dangerous spaces on an offshore liquefied gas terminal is to be consistent with the following general guidelines. Where there is overlapping, in general, the higher (more conservative) delineation should be applied.

The delineation of gas-dangerous spaces in 5C-8-1/2.24 of the *Marine Vessel Rules* and Chapter 7, Section 10.7 of NFPA 59A, as applicable, will be considered applicable to liquefied gas storage and liquefied gas and liquefied gas vapor piping systems associated with liquefied gas storage, loading and discharge.

The delineation of gas-dangerous spaces associated with process facilities is to comply with the requirements of 3-6/15 of the *Facilities Rules*, which are consistent with API RP 500 series.

The delineation of hazardous areas associated with the below deck storage of condensate and other hydrocarbon liquids with a flash point of less than 60°C is to be consistent with the requirements of 5C-1-7/31.5 of the *Marine Vessel Rules*.

Where condensate in the condensate storage tank contains dangerous or noxious liquid chemical substances as defined in the "International Code for the Construction and Equipment of Ships Carrying

Dangerous Chemicals in Bulk” (IBC Code), the requirements applicable to the particular substances as specified in Chapter 9 of Part 5C of the *Marine Vessel Rules* are also to be complied with.

17 Process Support and Service Systems

This Subsection presents criteria for the design and installation of process support and service systems on offshore liquefied gas terminals. General arrangement of these systems is to comply with API RP 14J, or other applicable standard. Process support systems are utility and auxiliary systems that complement the process systems covered in 2-2/11 of this Guide.

Process support systems include, but are not limited to, the following:

- i) Utility/Instrument Air System
- ii) Fuel/Instrument Gas System
- iii) Use of Produced Gas as Fuel
- iv) Purging System
- v) Inert Gas System
- vi) Nitrogen System
- vii) Fuel Oil System
- viii) Hydraulic System
- ix) Lubricating Oil System
- x) Chemical Injection System
- xi) Heating and Cooling System

These systems are to be in compliance with the requirements of Section 3-4 of the *Facilities Rules* and Part 5C, Chapter 8 of the *Marine Vessel Rules*, as applicable.

Depending on the type of structure support systems and components may include, but are not limited to, the following:

- Boilers and Pressure Vessels
- Turbines and Gears
- Internal Combustion Engines
- Pumps and Piping Systems (i.e., Fuel Oil, Lube Oil, Fresh Water, Bilge, Ballast, Control, Inert Gas, etc.)
- Components of the station keeping system

These systems are to be in compliance with the requirements of Section 3-5 of the *Facilities Rules* and the applicable sections of the *Marine Vessel Rules* and the *MOU Rules*.

19 Electrical Systems and Installations

Electrical systems used solely for the process facilities described in 2-2/11 of this Guide are to meet the requirements of Section 5C-8-10 of the *Marine Vessel Rules* and Section 3-6 of the *Facilities Rules*. Where electrical systems or equipment are used to supply services other than these process facilities, the equipment is also to comply with the requirements of a recognized code for electrical installations acceptable to ABS.

Electrical installations are to comply with the above-referenced requirements and with API RP 14F. Consideration will be given to the use of other recognized national or international standards such as IEC, provided they are no less effective and the entire system is designed to such standards. For installations classified by class and zone, the requirements of API RP 14FZ (when approved) may be used in lieu of API 14F.

Where sections of API RP 14F are called out in the following text, the intent is solely to help identify relevant clauses. The designer is not relieved from full compliance with all of the recommended practices contained in API RP 14F. The references to IEC standards are intended solely as minimum requirements when standards other than API RP 14F are applied.

Where conflicts exist between various referenced standards, ABS is to be consulted to provide required clarification.

21 Instrumentation and Control Systems

The control and instrumentation systems are to provide an effective means for monitoring and controlling pressures, temperatures, flow rates, liquid levels and other process variables for the safe and continuous operation of the process and storage facilities. Where control over the electrical power generation and distribution is required for the operation of the facilities, then the control system should also be arranged to cover this. Control and instrumentation systems for process, process support, utility and electrical systems are to be suitable for the intended application. All control and safety shutdown systems are to be designed for safe operation of the equipment during start-up, shutdown and normal operational conditions.

Instrumentation and control systems serving the process facilities described in 2-2/11 of this Guide are to be in compliance with Section 3-7 of the *Facilities Rules* which is based on API RP 14C and other applicable standards.

Instrumentation and control systems serving the liquefied gas storage and transfer of liquefied gas and liquefied gas vapor on and off the unit are to be in compliance with the requirements of Section 5C-8-13 of the *Marine Vessel Rules*.

Where there is a conflict between overlapping referenced requirements, ABS is to be consulted for required clarification.

23 Safety Systems

23.1 General

23.1.1 Approach

The safety systems referred to in this Subsection are intended to protect life, property and the environment and are applicable to the entire installation, including the loading and off-loading arrangements for gas, liquefied gas and liquefied gas vapor. The overall safety system should be comprised of subsystems providing two levels of protection: the primary system, which is to provide protection against the risk of fire or explosion; and the secondary system, which is intended to reduce the consequence of fire by affording protection to the people and the facility and reducing the risk of fire spread. The primary and secondary safety measures required consist of both active and passive systems as described in this Subsection. However, in all cases, the effectiveness of these systems should be established by conducting a fire and explosion hazard analysis.

Each space considered a fire risk, such as the process equipment, cargo deck area, spaces containing gas processing equipment such as compressors, heaters, etc. and machinery spaces containing any oil fired unit or internal combustion machinery with an aggregate power of not less than 375 kW, is to be fitted with an approved gas detection, fire detection and fire extinguishing system complying with the requirements of this Subsection.

23.1.2 Governmental Authority

In addition to the ABS Class requirements of this Subsection, depending on the flag registry of the terminal and the area of operation, the flag State and the coastal State may have additional requirements or regulations which may need to be complied with. Therefore, the appropriate governmental authorities should be consulted for each installation.

23.1.3 Primary Systems

Many of the products being handled onboard an offshore liquefied gas terminal are highly flammable, and therefore, examples of some of the measures that may be necessary to protect against fire or explosion risk are as follows:

- i) Avoid the possibility of liquid or gas escaping in locations where there is a source of vapor ignition. A typical example of this will be to isolate the vent and relief valve outlets from storage tanks and process systems in relation to the air intakes and openings.
- ii) Provide fixed gas detection systems comprised of two different types of elements which will activate an audible alarm at a manned control station to alert of a gas release before the gas can migrate to an unclassified area.
- iii) A low temperature detection system in and around the liquefied gas storage facility to alarm at a normally manned station to alert in the event of a liquid or vapor leak.
- iv) A multi-tiered Emergency Shutdown system capable of isolating an upset condition with local system or single train shutdowns before the condition requires a complete platform shutdown.
- v) Maintain integrity of the containment boundary at all times to reduce the possibility of an uncontrolled discharge of liquefied gas or liquefied gas vapor. Where it is possible for liquefied gas to leak in the event of a failure, such as at a joint, valve or similar connection, a spill tray immediately underneath these components should be provided.
- vi) Maintain a positive separation between process areas, cargo storage, cargo handling area and areas containing sources of vapor ignition. A typical example of this is electrically driven cargo or process compressors.
- vii) Eliminate direct access from the space containing process equipment to spaces containing machinery such as electrical equipment, fired equipment or other similar equipment which may be considered an ignition source.

23.1.4 Secondary Systems

The secondary systems are systems that are employed to prevent the spread of fire may be categorized as follows:

- i) Fire detection system
- ii) Fire extinguishing systems
- iii) Water deluge system
- iv) Personnel protection and life saving appliances
- v) Structural fire protection

23.3 Gas Detection Systems

23.3.1

The fixed gas detection system is to comply with requirement of Section 5C-8-13 of the *Marine Vessel Rules* and Section 3-8 and of the *Facilities Rules*.

23.3.2

The requirements of NFPA 59A Chapter 12 will be considered to be applicable in the liquefied gas processing areas. In such areas, where there is a potential for gas concentrations to accumulate, the gas detection sensors should activate an audible and visual alarm at not more than 25% of the lower flammable limit of the gas or vapor being monitored.

23.3.3

The gas detection system is to be of an approved type and the installation arrangements such that loss of single detector(s) over a specific area will not render the entire system ineffective.

23.3.4

The gas detection system should be provided with an alternative source of power such that in the event of failure of the main power source, the alternative power supply will commence automatically.

23.5 Fire Detection Systems

The fire detection system protecting the liquefied gas storage and liquefied gas and liquefied gas vapor handling systems is to be in accordance with the requirements of Section 5C-8-11 of the *Marine Vessel Rules* and Section 3-8 of the *Facilities Rules*, as applicable. The requirements of NFPA 59A Chapter 9 are also considered applicable.

23.7 Fire Extinguishing and Water Spray (Deluge) Systems

NFPA 59A Chapter 12 is considered applicable to offshore liquefied gas terminals, and as is required therein, the extent of fire protection required shall be determined by an evaluation based on sound fire protection engineering principles, analysis of local conditions, hazards within the facility and exposure to or from other sources of fire such as the attending vessels.

Fire water systems, water spray systems, dry powder, foam and carbon dioxide systems are to be provided, as required by Section 5C-8-11 of the *Marine Vessel Rules* and Section 3-8 of the *Facilities Rules*.

23.9 Structural Fire Protection

The term “structural fire protection” refers to the passive method of providing fire protection to the spaces/compartments of the unit through the usage of fire divisions and the limitation of combustibles in the construction materials. Maintaining the adequacy of the fire division includes proper protection of penetrations in those divisions which includes electrical, piping or ventilation system penetrations.

The requirements of 3-8/9 of the *Facilities Rules* are to be complied with. In applying these requirements, the gas inlet and liquefied gas vapor outlet system, including the swivel, are to be treated as wellhead areas.

23.11 Personnel Protection and Life Saving Appliances

Compliance with 5C-8-14 of the *Marine Vessel Rules* and Section 3-8 of the *Facilities Rules* is required.

Personnel involved in emergency activities shall be equipped with the necessary protective clothing and equipment qualified in accordance with 5C-8-11/6 of the *Marine Vessel Rules* and NFPA 600 *Standard on Industrial Fire Brigades*.

Written practices and procedures shall be developed to protect personnel from identified hazards such as entry into confined or hazardous spaces.

23.13 Means of Escape

At least two means of escape are to be provided for all continuously manned areas and areas that are used on a regular working basis. The two means of escape must be through routes that minimize the possibility of having both routes blocked in an emergency situation. Escape routes are to have a minimum width of

0.71 m (28 in.). Dead-end corridors exceeding 7 m (23 ft.) in length are not permitted. Dead-end corridors are defined as a pathway which (when used during an escape) has no exit.

Escape route paths are to be properly identified and provided with adequate lighting. An escape route plan is to be prominently displayed at various points in/of the facility. Alternatively, this information may be included in the Fire Control or Fire/Safety Plan.

23.15 Emergency Shutdown Systems

23.15.1 Process Emergency Shutdown (ESD)

An emergency shutdown (ESD) system with manual stations is to be provided, in accordance with Appendix C of API RP14 and Section 12.3 of NFPA 59A, to shut down the flow of hydrocarbon gas on to the platform and to terminate all gas processing and liquefaction process on the facility.

In addition, for the liquefied gas loading and discharge systems and the liquefied gas storage systems, Emergency Shutdown Valves are to be provided along with means for control, in accordance with 5C-8-5/5 of the *Marine Vessel Rules*.

The emergency shutdown system is to be automatically activated by:

- i)* The detection of an abnormal operating condition by pressure sensors in the inlet and outlet systems or in the process systems
- ii)* The detection of fire on the floating terminal
- iii)* The detection of combustible gas at a 60% level of the lower explosive limit
- iv)* The detection of hydrogen sulfide (H₂S) gas at a level of 50 ppm

Emergency shutdown stations are to be provided for manual activation of the Process Safety Shutdown system for shutdown of all pumping and process systems. These manual activation stations are to be protected against accidental activation and are to be conveniently located at the primary evacuation points (i.e., boat landing, helicopter deck, etc.) and the emergency control stations.

For design guidance, the following additional locations may be considered appropriate for emergency shutdown stations:

- i)* Exit stairway at each deck level
- ii)* Main exits of living quarters
- iii)* Main exits of production (process) facility deck

25 Other Systems

For marine systems or electrical systems associated with marine operations and accommodations, the relevant ABS requirements as referenced in the *FPI Rules* and/or *MOU Rules* and/or *Marine Vessel Rules* are to be complied with.

CHAPTER 3
Structural Design Requirements

CONTENTS

SECTION	1	Introduction.....	60
	1	Application.....	60
	1.1	General.....	60
	1.3	Membrane Tanks.....	60
	1.5	Independent Tanks.....	60
	1.7	Direct Calculations.....	61
	1.9	Offshore Hull Construction Monitoring Program.....	61
	3	Internal Members.....	61
	3.1	Section Properties of Structural Members.....	61
	3.3	Detailed Design.....	62
	3.5	Breaks.....	63
	3.7	Variations.....	63
	3.9	Loading Guidance.....	63
	3.11	Design Vapor Pressure.....	63
	3.13	Protection of Structure.....	63
	3.15	Aluminum Paint.....	63
	3.17	Containment System.....	63
	3.19	Determination of Temperature Distribution for Material Selection.....	63
	TABLE 1	Design Ambient Temperatures	63
	TABLE 2	Cargo Properties of Common Liquefied Gas Cargoes	64
	FIGURE 1	62
SECTION	2	General Requirements.....	66
	1	General Requirements	66
	1.1	General.....	66
	1.3	Initial Scantling Requirements (1 September 2012).....	67
	1.5	Strength Assessment - Failure Modes.....	67
	1.7	Structural Redundancy and Residual Strength.....	67

1.9	Strength Against Blast Loads.....	68
3	Net Scantlings and Nominal Design Corrosion Values	68
3.1	General (1 September 2012).....	68
3.3	Nominal Design Corrosion Values for Design Life Greater than 20 Years (1 September 2012).....	72

TABLE 1	Nominal Design Corrosion Values ^(1, 2) (1 September 2012).....	70
---------	---	----

FIGURE 1A	Nominal Design Corrosion Values.....	69
FIGURE 1B	Nominal Design Corrosion Values (1 September 2012).....	69
FIGURE 1C	Nominal Design Corrosion Values.....	70
FIGURE 1D	Nominal Design Corrosion Values.....	70

SECTION 3 Load Criteria..... 73

1	General	73
1.1	The Concept and Application of Environmental Severity Factors.....	73
1.3	Load Components.....	73
3	Static Loads	73
3.1	Still-water Bending Moment and Shear Force.....	73
3.3	Additional Special Loading Patterns for Independent Cargo Tanks.....	74
5	Wave-Induced Loads	79
5.1	Wave-Induced Longitudinal Bending Moments and Shear Forces.....	80
5.3	Horizontal Wave Bending Moments and Shear Forces... 81	
5.5	External Pressures.....	84
5.7	Internal Pressures - Inertia Forces and Added Pressure Heads.....	86
5.9	Internal Pressures - IGC Code.....	91
7	Nominal Design Loads.....	106
7.1	General.....	106
7.3	Hull Girder Loads - Longitudinal Bending Moments and Shear Forces.....	107
7.5	Local Loads for Design of Main Supporting Structures. 107	
7.7	Local Pressures for Design of Plating and Longitudinals.....	108
9	Combined Load Cases.....	108
9.1	Combined Load Cases for Structural Analysis.....	108
9.3	Combined Load Cases for Failure Assessment.....	108
11	Sloshing Loads in Membrane Tanks.....	108
11.1	General.....	108
11.3	Strength Assessment of Tank Boundary Structures.....	109
11.5	Sloshing Pressures.....	109

13	Sloshing Loads for Prismatic Independent Tanks	117
13.1	General.....	117
13.3	Strength Assessment of Tank Boundary Structures.....	117
13.5	Sloshing Pressures.....	118
14	Thermal Loads for Prismatic Independent Tanks (<i>1 September 2012</i>).....	125
14.1	General.....	125
14.3	Thermal Loading Conditions.....	125
14.5	Allowable Stresses.....	126
15	Impact Loads.....	126
15.1	Impact Loads on Bow.....	126
15.3	Bottom Slamming.....	127
15.5	Bowflare Slamming.....	129
15.7	Green Water on Deck.....	133
17	Deck Loads.....	134
17.1	General.....	134
17.3	Loads for On-Site Operation.....	134
17.5	Loads in Transit Condition.....	135
17.7	Temperature Loads.....	135
TABLE 1A	Combined Load Cases* for Total Strength Assessment (<i>2018</i>).....	99
TABLE 1B	Additional IGC Load Cases* for Initial Scantling Evaluation of Main Supporting Members in Membrane Tank FLGTs by FEA.....	100
TABLE 1C	Special Design Load Cases for Independent Cargo Tanks (<i>1 September 2012</i>)(One side of Tank Loaded and Accidental Load Cases).....	101
TABLE 1D	Combined Load Cases for Repair Condition*.....	102
TABLE 2	Load Cases for Sloshing.....	103
TABLE 3	Design Pressure for Local and Supporting Members (<i>2018</i>).....	104
TABLE 4	Definition of d_p , $C_{\phi i}$ and $C_{\theta r}$	113
TABLE 5	Values of α	128
TABLE 6	Values of A_i and B_i^*	131
TABLE 7	Values of A_r	133
TABLE 8	Correlation Factors c_v , c_T , c_L , C_ϕ and C_θ	135
FIGURE 1A	Loading Pattern.....	75
FIGURE 1B	Loading Pattern.....	76
FIGURE 1C	Special Loading Patterns for Independent Cargo Tanks.....	77
FIGURE 2A	Distribution Factor M	82
FIGURE 2B	Distribution Factor m_h	82
FIGURE 3A	Distribution Factor F_1	83
FIGURE 3B	Distribution Factor F_2	83

FIGURE 3C	Distribution Factor f_h	84
FIGURE 4	Distribution of h_{D1}	94
FIGURE 5	Pressure Distribution Function $k_{\rho 0}$	95
FIGURE 6	Illustration of Determining Total External Pressure.....	95
FIGURE 7A	Tank Shape Parameters.....	96
FIGURE 7B	Definition of Tank Geometry.....	97
FIGURE 8	Acceleration Ellipse.....	98
FIGURE 9	Determination of Internal Pressure Heads.....	98
FIGURE 10	<i>Location of Tank for Nominal Pressure Calculation</i>	99
FIGURE 11	Definition of Tank Geometry.....	113
FIGURE 12	Vertical Distribution of Nominal Slosh Pressure Head, h_e ..	114
FIGURE 13	Vertical Distribution of Nominal Slosh Pressure Head, h_i for Low-Filling Resonance.....	114
FIGURE 14	Distribution of Nominal Slosh Pressure Head, h_t on Tank Top.....	115
FIGURE 15	Horizontal Distribution of Simultaneous Slosh Pressure Heads, $h_c (\phi_s \theta_s)$ or $h_t (\phi_s \theta_s)$	116
FIGURE 16A	Loading Patterns for Sloshing Loads Cases.....	116
FIGURE 16B	Loading Patterns for Sloshing Loads Cases.....	117
FIGURE 17	Vertical Distribution of Equivalent Slosh Pressure Head, h_e	123
FIGURE 18	Definitions for Opening Ratio, α	123
FIGURE 19	Opening Ratios.....	124
FIGURE 20	Dimensions of Internal Structures.....	125
FIGURE 21	Definition of Bow Geometry.....	127
FIGURE 22	Distribution of Bottom Slamming Pressure Along the Section Girth.....	129
FIGURE 23	Definition of Bowflare Geometry for Bowflare Shape Parameter.....	132
FIGURE 24	Stem Angle, γ	132

SECTION	4 Initial Scantling Criteria.....	137
1	General	137
1.1	Strength Requirement.....	137
1.3	Calculation of Load Effects.....	137
1.5	Structural Details.....	137
1.7	Evaluation of Grouped Stiffeners.....	138
3	Hull Girder Strength.....	138
3.1	Still-water Loads.....	138
3.3	Wave Induced Loads.....	138
3.5	Hull Girder Section Modulus.....	138
3.7	Hull Girder Moment of Inertia.....	139
3.9	Hull Girder Ultimate Strength.....	140
3.11	Minimum Scantlings for ESF Approach.....	140
3.13	Loading Manual.....	140

5	Shearing Strength	140
5.1	General.....	140
5.3	Net Thickness of Side Shell Plating.....	141
5.5	Net Thickness of Longitudinal Bulkheads.....	142
5.7	Calculation of Local Loads.....	143
5.9	Application of 3D FEM (1 June 2014).....	144
7	Double Bottom Structures.....	146
7.1	General.....	146
7.3	Bottom Shell and Inner Bottom Plating.....	147
7.5	Bottom, Bilge and Inner Bottom Longitudinals.....	152
7.7	Double Bottom Girders and Floors.....	155
7.9	Structure in Pipe Duct Space.....	163
9	Side Shell and Deck.....	169
9.1	Side Shell Plating (1 June 2014).....	169
9.3	Sheerstrake.....	173
9.5	Deck Plating.....	173
9.7	Deck and Side Longitudinals (1 June 2014).....	179
11	Side Shell and Deck - Main Supporting Members.....	183
11.1	General.....	183
11.3	Deck Transverses.....	183
11.5	Deck Girders.....	184
11.7	Side Transverses.....	186
11.9	Side Stringers.....	188
11.11	Side Frame.....	190
11.13	Web Stiffeners and Tripping Brackets.....	192
11.15	Slots and Lightening Holes.....	192
13	Longitudinal and Transverse Bulkheads.....	195
13.1	Longitudinal Bulkhead Plating.....	195
13.3	Transverse Bulkhead Plating.....	197
13.5	Longitudinals and Vertical/Horizontal Stiffeners.....	199
13.7	Longitudinal Stool Plating (1 September 2012).....	201
13.9	Longitudinal Stiffeners on Longitudinal Stool Plate (1 September 2012).....	202
15	Transverse Bulkheads - Main Supporting Members.....	203
15.1	General.....	203
15.3	Vertical Webs.....	203
15.5	Horizontal Web.....	205
15.7	Stiffeners, Tripping Brackets, Slots and Lightening Holes.....	208
17	Independent Cargo Tank Structures.....	210
17.1	General (1 September 2012).....	210
17.3	Allowable Stresses and Corrosion Allowances.....	210
19	Supports	213

TABLE 1	Minimum Net Thickness of Girders and Floors.....	168
FIGURE 1A	Definition of b_s and Extent for Calculating A_{ob} and A_s - Single Center Cargo Tank.....	145
FIGURE 1B	Definition of b_s and Extent for Calculating A_{ib} and A_s - Two Tanks Abreast.....	146
FIGURE 2	147
FIGURE 3	Unsupported Span of Longitudinal.....	167
FIGURE 4	Effective Breadth of Plating b_e	168
FIGURE 5	Definitions of ℓ_s and b_{DB}	169
FIGURE 6	Definition of Parameters for Deck and Side Structure.....	193
FIGURE 7	Effectiveness of Brackets.....	195
FIGURE 8	Transverse Bulkhead Structures.....	209

SECTION	5 Total Strength Assessment.....	214
1	General Requirements.....	214
1.1	General.....	214
1.3	Loads and Load Cases.....	214
1.5	Stress Components.....	214
3	Failure Criteria - Yielding	215
3.1	General.....	215
3.3	Structural Members and Elements.....	215
3.5	Plating.....	216
3.7	Allowable Stresses for Independent Cargo Tanks.....	217
3.9	Allowable Stresses for Main Supporting Members and Structural Details.....	219
3.11	Allowable Stresses for Vertical Supports and Chocks...	219
5	Failure Criteria - Buckling and Ultimate Strength.....	220
5.1	General.....	220
5.3	Plate Panels.....	221
5.5	Longitudinals and Stiffeners.....	223
5.7	Stiffened Panels.....	224
5.9	Girders and Webs.....	225
5.11	Independent Cargo Tank Structures.....	226
7	Fatigue Life.....	226
7.1	General.....	226
7.3	Procedures.....	227
7.5	Spectral Analysis.....	227
7.7	Independent Cargo Tank Structures.....	228
9	Calculation of Structural Responses	228
9.1	Methods of Approach and Analysis Procedures.....	228
9.3	3D Finite Element Models.....	228
9.5	Local Structural Models.....	228

	9.7	Load Cases.....	228
	TABLE 1	Allowable Stresses (kgf/cm ²) for Various Finite Element Mesh Sizes	219
	TABLE 2	Allowable Stresses (kgf/cm ²) for Various Finite Element Mesh Sizes	219
SECTION	6	Hull Structure Beyond 0.4L Amidships.....	229
	1	General Requirements.....	229
	1.1	General.....	229
	1.3	Structures within the Cargo Space Length (1 June 2014).....	229
	3	Forebody Side Shell Structure.....	229
	3.1	Side shell Plating (1 June 2014).....	229
	3.3	Side Frames and Longitudinals.....	231
	3.5	Side Transverses and Stringers in Forebody.....	232
	5	Transition Zone	240
	7	Forebody Strengthening for Slamming.....	240
	7.1	Bottom Slamming.....	241
	7.3	Bowflare Slamming.....	242
	9	Deck Structures in Forebody (1 September 2012).....	243
	9.1	Deck Plating.....	243
	9.3	Deck Longitudinals/Beams.....	244
	FIGURE 1	Transverse Distribution of p_d	232
	FIGURE 2	Definition of Spans	240
SECTION	7	Design and Analysis of Other Major Hull Structural Features....	245
	1	General.....	245
	3	Position Mooring Hull Interface	245
	3.1	Turret or SPM Type Mooring System, External to the Hull Structure.....	246
	3.3	Mooring System Internal to the Hull Structure (Turret Moored).....	246
	3.5	Spread Moored Installations.....	247
	5	Hull Mounted Equipment Interface	247
	5.1	Topside Module Support Stools and Hull Underdeck Structures.....	247
	5.3	Other Hull Mounted Equipment Foundation Structures.....	247
	7	Loads.....	248
	7.1	Load Conditions.....	248
	7.3	Inertial Load Cases.....	249
	7.5	Hull Girder Load Cases.....	249
	9	Acceptance Criteria.....	249

9.1	Yielding Checks (1 September 2012).....	249
9.3	Buckling Checks.....	251
9.5	Fatigue Calculations.....	251
11	Modules on Deck	253
11.1	General.....	253

TABLE 1	Fatigue Design Factors for Fatigue Life of Hull Interface Structures (1 September 2012).....	251
---------	---	-----

FIGURE 1	Loading Pattern 1 with 2/3 Scantling Draft	247
----------	--	-----

FIGURE 2	Loading Pattern 2 with Scantling Draft	247
----------	--	-----

APPENDIX 1 Guide for Fatigue Strength Assessment..... 254

1	General.....	254
1.1	Note.....	254
1.3	Applicability.....	254
1.5	Loadings.....	254
1.7	Effects of Corrosion.....	254
1.9	Format of the Criteria.....	254
3	Connections to be Considered for the Fatigue Strength Assessment	255
3.1	General.....	255
3.3	Guidance on Locations.....	255
5	Fatigue Strength Assessment.....	261
5.1	Assumptions.....	261
5.3	Criteria.....	261
5.5	Long Term Stress Distribution Parameter, γ	261
5.7	Cumulative Fatigue Damage.....	262
7	Fatigue Inducing Loads and Determination of Total Stress Ranges	265
7.1	General.....	265
7.3	Wave-induced Loads - Load Components.....	265
7.5	Fatigue Assessment - Loading Conditions.....	266
7.7	Primary Stress $f_d 1$	272
7.9	Secondary Stress $f_d 2$	272
7.11	Additional Secondary Stresses $f_d 2^*$ and Tertiary Stresses $f_d 3$	272
9	Resulting Stress Ranges.....	275
9.1	Definitions.....	275
11	Determination of Stress Concentration Factors (SCF's).....	276
11.1	General.....	276
11.3	Sample Stress Concentration Factors (SCF's).....	277

13	Stress Concentration Factors Determined From Finite Element Analysis	282
13.1	Introduction.....	282
13.3	S-N Data.....	282
13.5	S-N Data and SCF's.....	283
13.7	Calculation of Hot Spot Stress for Fatigue Analysis.....	285
15	Fatigue Assessment of Structures Considering Low Cycle Fatigue.....	285
15.1	Introduction.....	285
15.3	Applicability.....	286
15.5	Loads.....	286
15.7	Selection of Loading Conditions for Low Cycle Fatigue	286
15.9	Acceptance Criteria.....	287
15.11	Fatigue Assessment Methods.....	287
17	Low Cycle Fatigue Damage.....	288
17.1	Low Cycle Fatigue Load.....	288
17.3	Loading Conditions.....	288
17.5	Stress Range Calculation.....	288
19	Combined Fatigue Damage.....	291
TABLE 1	Fatigue Classification for Structural Details.....	258
TABLE 2A	Design Fatigue Load Cases for Fatigue Strength Assessment.....	267
TABLE 2B	Design Fatigue Load Cases for Fatigue Strength Assessment.....	268
TABLE 2C	Design Fatigue Load Cases for Fatigue Strength Assessment.....	269
TABLE 2D	Design Fatigue Load Cases for Fatigue Strength Assessment.....	270
TABLE 3	K_s (SCF) Values.....	277
FIGURE 1	Hold Frames.....	256
FIGURE 2	Connection between Inner Bottom and Hopper Tank Slope	256
FIGURE 3	Hatch Corner.....	257
FIGURE 4	Doublers and Non-load Carrying Members on Deck or Shell Plating.....	257
FIGURE 5	Basic Design S-N Curves	264
FIGURE 6	Loading Conditions for Fatigue Strength Assessment.....	266
FIGURE 7	$C_n = C_n(\Psi)$	275
FIGURE 8	Cut-outs (Slots) For Longitudinal.....	279
FIGURE 9	Fatigue Classification for Longitudinals in way of Flat Bar Stiffener	281
FIGURE 10	281
FIGURE 11	282

FIGURE 12	Doublers and Non-load Carrying Members on Deck or Shell Plating.....	282
FIGURE 13	284
FIGURE 14	285
FIGURE 15	285
FIGURE 16	Sample Functions of S_W and S_B	288
FIGURE 17	A Single Loading/Offloading Cycle.....	289
FIGURE 18	k_e as a Function of S_E	290
FIGURE 19	Low Cycle Fatigue Design Curve.....	291
APPENDIX 2	Calculation of Critical Buckling Stresses.....	293
1	General.....	293
3	Rectangular Plates.....	293
5	Longitudinals and Stiffeners.....	295
5.1	Axial Compression.....	295
5.3	Torsional/Flexural Buckling.....	296
7	Stiffened Panels.....	298
7.1	Large Stiffened Panels.....	298
9	Girders, Webs and Stiffened Brackets.....	299
9.1	Critical Buckling Stresses of Web Plates and Large Brackets.....	299
9.3	Effects of Cut-outs.....	300
9.5	Tripping.....	300
11	Stiffness and Proportions.....	301
11.1	Stiffness of Longitudinals.....	301
11.3	Stiffness of Web Stiffeners.....	301
11.5	Stiffness of Supporting Members.....	302
11.7	Proportions of Flanges and Face Plates.....	302
11.9	Proportions of Webs of Longitudinals and Stiffeners.....	302
TABLE 1	Buckling Coefficient, K_i	294
FIGURE 1	Net Dimensions and Properties of Stiffeners	297
FIGURE 2	299
APPENDIX 3	Determination of Environmental Severity Factors.....	303
1	General.....	303
3	ESFs of the Beta (β) Type.....	303
5	ESFs of the Alpha (α) Type	305
TABLE 1	The 13 Dynamic Load Parameters or ESFs (β_{NN})	304
APPENDIX 4	Hull Girder Ultimate Strength.....	307

1	Plate Element.....	308
1.1	Yielding in Tension.....	308
1.3	Buckling in Compression.....	309
3	Stiffener Element.....	311
3.1	Yielding in Tension.....	312
3.3	Beam-Column Buckling.....	312
3.5	Torsional-Flexural Buckling.....	312
3.7	Local Buckling of Stiffeners.....	313
5	Corner Element.....	314
FIGURE 1	Flow Chart for the Evaluation of the Bending Moment-Curvature Curve, $M-\chi$	310
FIGURE 2	Load-End Shortening Curve for Plate Element.....	311
FIGURE 3	Load-End Shortening Curve for Beam-Column Buckling...312	
FIGURE 4	Load-End Shortening Curve for Torsional-Flexural Buckling.....	313
FIGURE 5	Load-End Shortening Curve for Local Buckling.....	314
FIGURE 6	Load-End Shortening Curve for a Corner Element.....	315

APPENDIX 5 Hull Structural Modeling and Analysis..... 316

1	Objective.....	316
3	Scope of Application.....	316
5	Extent of the 3-D Global Finite Element Model.....	317
7	Coordinate System of the Model.....	317
9	Element Types.....	317
9.1	Plate Elements.....	318
9.3	Bar (or Beam) Elements for Stiffeners.....	321
9.5	Rod (or Truss) Elements for Stiffeners.....	321
9.7	Rod Elements for Face Plates of Primary Supporting Members (1 September 2012).....	321
11	3-D Global FE Modeling.....	321
11.1	Modeling of Hull and Cargo Tank Structures.....	321
11.3	Modeling of Supports and Chocks.....	322
11.5	Finite Element Modeling for Critical Structural Areas....	323
11.7	Finite Element Modeling for Critical Structural Details...329	
13	Loading Conditions.....	331
13.1	Combined Load Cases and Loading Pattern.....	331
13.3	Sloshing Load Cases.....	331
13.5	Target Hull Girder Vertical Bending Moment and Vertical Shear Force (1 September 2012).....	331
13.7	Target Hull Girder Horizontal Wave Bending Moment (1 September 2012).....	332
15	Procedure to Adjust Hull Girder Shear Force and Bending Moment.....	332

15.1	General (1 September 2012).....	332
15.3	Shear Force and Bending Moment due to Local Loads	332
15.5	Procedure to Adjust Vertical Shear Force Distribution to Target Values.....	333
15.7	Procedure to Adjust Vertical and Horizontal Bending Moments to Target Values (1 September 2012).....	339
17	Boundary Conditions.....	341
17.1	General.....	341
17.3	Calculation of Spring Stiffness.....	342
19	Validation of 3-D Global Response.....	344
19.1	Correlation with Beam Theory.....	344
19.3	Additional Remarks.....	344
21	Detailed Stress Assessment - Local FEA.....	345
21.1	General.....	345
21.3	Analysis Model.....	345
21.5	Analysis Criteria.....	346
TABLE 1	Shear Force Distribution Factors.....	339
TABLE 2	Boundary Constraints at Model Ends	342
TABLE 3	Shear Areas to be Considered for the Calculation of Spring Stiffness	343
FIGURE 1	Extent of 3-D Global Finite Element Model.....	317
FIGURE 2	Typical Finite Element Mesh on Web Frame	319
FIGURE 3	Typical Finite Element Mesh on Transverse Bulkhead	320
FIGURE 4	Typical Finite Element Mesh on Transverse Web Frame Main Bracket	320
FIGURE 5	Global Finite Element Model of Hull and Tank Structure (Main Supporting Members, Supports and Chocks).....	323
FIGURE 6	Modeling of Bracket Toe and Tapered Face Plate.....	324
FIGURE 7	Critical Areas of Hull and Cargo Tank Structures.....	325
FIGURE 8	Mesh Arrangement for Critical Structural Areas (Vertical Support).....	326
FIGURE 9	Mesh Arrangement for Critical Structural Areas (Anti-Rolling Chock).....	327
FIGURE 10	Mesh Arrangement for Critical Structural Areas (Anti-Pitching Chock).....	328
FIGURE 11	Mesh Arrangement for Critical Structural Areas (Anti-Flotation Chock).....	329
FIGURE 12	Fine Mesh Finite Element Analysis for Fatigue Strength Evaluation.....	330
FIGURE 13	Position of Target Shear Force and Required Shear Force Adjustment at Transverse Bulkhead Positions	335
FIGURE 14	Distribution of Adjusting Vertical Force at Frames and Resulting Shear Force Distributions.....	336
FIGURE 15	Distribution of Adjusting Load on a Transverse Section....	338

FIGURE 16 Spring Constraints at Model Ends341

APPENDIX 6 Guide for Offshore Hull Construction Monitoring Program..... 347

- 1 Introduction..... 347
- 3 Application..... 347
- 5 Critical Area..... 347
- 7 Determination of Critical Areas..... 348
- 9 Construction Monitoring Plan..... 348
- 11 Surveys After Construction..... 348
- 13 Notation..... 348

CHAPTER 3 Structural Design Requirements

SECTION 1 Introduction

1 Application

1.1 General

This Guide addresses the structural design of floating offshore membrane or independent prismatic tank liquefied gas terminals with ship-shaped or barge-shaped hull forms having single center cargo tanks or two cargo tanks abreast that are arranged along the centerline of the terminal's hull. In view of the similarity of hull structure, this Guide has some cross-references to the general requirements for hull construction in the Part 5C, Chapter 12 of the *Marine Vessel Rules*, the *ABS Guide for Building and Classing Liquefied Gas Carriers with Independent Tanks* and the particular requirements in Part 5C, Chapter 8 of the *Marine Vessel Rules* for vessels intended to carry liquefied gases in bulk. These cross-references are presented in a simple format throughout the Guide in order to provide quick reference to the users, (i.e., of the *Marine Vessel Rules* denotes 1-2-3/4.5.6 of the *Marine Vessel Rules*).

1.3 Membrane Tanks

These requirements are intended to apply to floating steel liquefied gas terminals with membrane type tanks as defined in 5C-8-4/1.5 of the *Marine Vessel Rules*. The technical requirements of the *International Code for the Construction and Equipment of Ships Carrying Liquefied Gases in Bulk (IGC Code)* are also to be followed.

1.5 Independent Tanks (2024)

These requirements are intended to apply to floating steel terminals engaged in the carriage of liquefied gases in independent tanks (Type A, Type B, and Type C) as defined in 5C-8-4/21.1.1 of the *Marine Vessel Rules*. The technical requirements of the *International Code for the Construction and Equipment of Ships Carrying Liquefied Gases in Bulk (IGC Code)* are also to be followed.

For Type A independent tanks, the scantling requirements and strength criteria in the Guide are considered equivalent to those in 5C-8-4/21 of the *Marine Vessel Rules*.

For Type B independent tanks, the requirements in 5C-8-4/22 of the *Marine Vessel Rules* with respect to crack propagation and fatigue failure are to be additionally verified. **The fatigue and fracture analysis is to be carried out for Type B Tanks to verify fatigue and crack propagation characteristics. The procedure for fatigue and fracture analysis is to be in accordance with 6/9.7 and Appendix 5 of the *ABS Guide for Building and Classing Liquefied Gas Carriers with Independent Tanks*.** The scantling requirements and

strength criteria in the Guide are considered equivalent to the remaining requirements in 5C-8-4/22 of the *Marine Vessel Rules*.

For Type C independent tanks (pressure vessels), the scantling requirements and strength criteria in 5C-8-4/23.2 of the *Marine Vessel Rules* are to be verified. The strength criteria in the Guide are considered equivalent to the remaining requirements in 5C-8-4/23.2 of the *Marine Vessel Rules*.

1.7 Direct Calculations

Direct calculations with respect to the determination of design loads and the establishment of alternative strength criteria based on first principles, will be accepted for consideration, provided that all the supporting data, analysis procedures and calculated results are fully documented and submitted for review. In this regard, due consideration is to be given to the environmental conditions, probability of occurrence, uncertainties in load and response predictions, and reliability of the structure in service.

1.9 Offshore Hull Construction Monitoring Program

For newbuild floating terminals, an Offshore Hull Construction Monitoring Plan for critical areas, prepared in accordance with the requirements of Appendix 3-A6 of this Guide, is to be submitted for approval prior to commencement of fabrication.

3 Internal Members

3.1 Section Properties of Structural Members

The geometric properties of structural members may be calculated directly from the dimensions of the section and the associated effective plating (see 3-1-2/13.3 of the *Marine Vessel Rules* or 3-4/7 FIGURE 4 of this Guide, as applicable). For structural members with angle θ (see 3-1/3.1 FIGURE 1) between web and associated plating not less than 75 degrees, the section modulus, web sectional area, and moment of inertia of the “standard” ($\theta = 90$ degrees) section may be used without modification. Where the angle θ is less than 75 degrees, the sectional properties are to be directly calculated about an axis parallel to the associated plating (see 3-1/3.1 FIGURE 1).

FIGURE 1

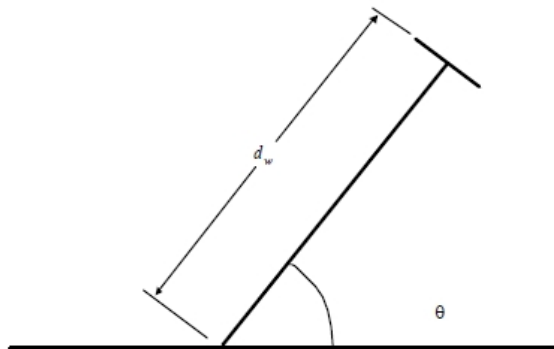
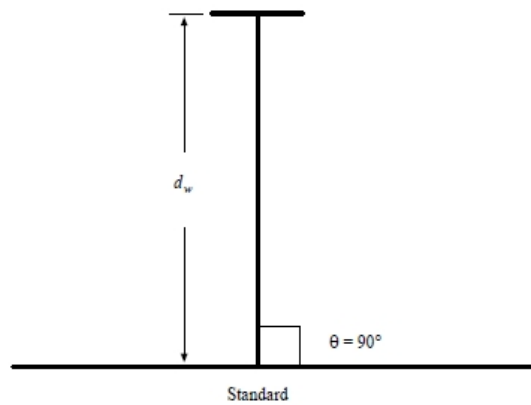

For longitudinals, frames and stiffeners, the section modulus may be obtained by the following equation:

$$SM = \alpha_{\theta} SM_{90}$$

where

$$\alpha_{\theta} = 1.45 - 40.5/\theta$$

$$SM_{90} = \text{section modulus at } \theta = 90 \text{ degrees}$$

The effective section area may be obtained from the following equation:

$$A = A_{90} \sin \theta$$

where

$$A_{90} = \text{effective shear area at } \theta = 90 \text{ degrees}$$

3.3 Detailed Design

The detail design of internals is to follow the guidance given in 3-1-2/15 of the *Marine Vessel Rules* and in 3-4/1.5 of this Guide.

See also Appendix 3-A1, "Guide for Fatigue Strength Assessment".

3.5 Breaks

Special care is to be taken to provide structural reinforcements against local stresses at the ends of the cargo tank spaces, superstructures, etc., and throughout the structure in general. The main longitudinal bulkheads are to be suitably tapered at their ends. Where effective longitudinal bulkheads are provided in the poop or deckhouse, they are to be located such as to provide effective continuity between the structure in way of and beyond the main cargo spaces.

3.7 Variations

Floating offshore liquefied gas terminals of a special type or design, differing from those described in this Guide, will be specially considered on the basis of equivalent strength.

3.9 Loading Guidance

Loading guidance is to be as required by 3-2-1/7 of the *Marine Vessel Rules* except that 3-4/5 of this Guide will apply for allowable shear stresses.

3.11 Design Vapor Pressure

The design vapor pressure p_o as defined in 5C-8-4/1.2 of the *Marine Vessel Rules* should not normally exceed 0.25 bar (0.255 kgf/cm², 3.626 lbf/in²). If, however, the hull scantlings are increased accordingly and consideration is given, where appropriate, to the strength of the supporting insulation, p_o may be increased to a higher value but less than 0.7 bar (0.714 kgf/cm², 10.153 lbf/in²).

3.13 Protection of Structure

For protection of the structure, see 3-2-18/5 of the *Marine Vessel Rules* as appropriate.

3.15 Aluminum Paint

Paint containing aluminum is not to be used in cargo tanks, pump rooms and cofferdams, or in any other area where cargo vapor may accumulate, unless it has been shown by appropriate tests that the paint to be used does not increase the fire hazard.

3.17 Containment System

Secondary barrier, insulation, materials, construction and testing of the cargo containment system are to comply with the applicable requirements in Section 5C-8-4 of the *Marine Vessel Rules*.

3.19 Determination of Temperature Distribution for Material Selection

The temperature distribution in the hull and cargo tank structures is to be determined based on the design ambient and cargo temperatures. 3-1/3.19 TABLE 1 summarizes the design ambient temperatures that are to be commonly used in the temperature distribution calculation. For vessels trading in other cold regions, the design ambient temperatures are to be specially considered.

TABLE 1
Design Ambient Temperatures

	<i>Air</i>	<i>Still Sea Water</i>
IMO IGC World-wide Services (5C-8-4/19.1.1 of the <i>Marine Vessel Rules</i>)	5°C (41°F) at 0 knots	0°C (32°F)
USCG Requirements for US Waters except Alaskan Waters (Appendix 5C-8-A2 of the <i>Marine Vessel Rules</i>)	-18°C (0°F) at 5 knots	0°C (32°F)
USCG Requirements for Alaskan Waters (Appendix 5C-8-A2 of the <i>Marine Vessel Rules</i>)	-29°C (-20°F) at 5 knots	-2°C (28°F)

The design temperature for cargo tanks is the minimum temperature at which cargo may be loaded or transported. The boiling temperatures and corresponding densities are listed in 3-1/3.19 TABLE 2 for some common liquefied gas cargoes.

The design temperature for cargo piping, cargo process pressure vessels and all associated equipment is the minimum temperature in the systems and components during the cargo operations.

The design temperature for a complete or partial secondary barrier is to be assumed to be the cargo temperature at atmospheric pressure.

For the purpose of determining the temperatures of the internal hull structural members beyond the cargo block, the ambient air temperature in the forebody and engine room spaces may be assumed to be 5°C (41°F).

The minimum temperature of the hull structure, tank supports and chocks is to be determined by direct temperature calculations, taking into account the efficiency of any insulation and means of heating if accepted according to 5C-8-4/10 and 5C-8-4/19 of the *Marine Vessel Rules*.

In absence of direct temperature calculations and for the purposes of material grade selection, the typical internal structural members (excluding tank supports and chocks) in liquefied gas carriers with Type A independent tanks may be determined with the following assumptions:

- The design temperature for the stiffeners is to be the same as that of the attached plating.
- The design temperature for the main supporting members without or away from large openings is to be taken as the average design temperature of the two adjoining plates.
- The design temperature for the main supporting members within large openings is to be the same as that of the attached plating.
- For Type A independent tank floating terminals the extent of the low temperature steel for deck plating between the two upper wing tanks is to be based on the 30-degree static heel condition.
- For Type A independent tank floating terminals the low temperature steel for the longitudinally continuous plating such as deck, inner bottom, and inner longitudinal bulkheads is to be extended 400 mm (15.75 in.) beyond the required position of the secondary barrier. The plating adjoining the low temperature steel is to be of E or DH Grade. The extent of such material grade need not be more than 400 mm. (15.75 in.)

TABLE 2
Cargo Properties of Common Liquefied Gas Cargoes

<i>Cargo</i>	<i>Chemical Formula</i>	<i>Vapor Detection</i>	<i>Boiling Temperature (°C)</i>	<i>Density (kg/m³)</i>
Acetaldehyde	CH ₃ CHO	F + T	+20.8	780
Ammonia, Anhydrous	NH ₃	T	-33.4	680
Butadiene 1.3 (inhibited)	CH ₂ CHCHCH ₂	F + T	-4.5	650
Butane, also called N-Butane	C ₄ H ₁₀	F	-0.5	600
Butane/Propane mixtures		F		630
Butylenes		F	-6.3	630
Chlorine	Cl ₂	T	-34	1560
Diethyl Ether	C ₂ H ₅ O C ₂ H ₅	F + T	34.6	640
Dimethylamine	(CH ₃) ₂ NH	F + T	6.9	670

<i>Cargo</i>	<i>Chemical Formula</i>	<i>Vapor Detection</i>	<i>Boiling Temperature (°C)</i>	<i>Density (kg/m³)</i>
Ethane	C ₂ H ₆	F + T	-88	550
Ethyl Chloride	CH ₃ CH ₂ Cl	F + T	12.4	920
Ethylene	C ₂ H ₄	F	-104	560
Ethylene Oxide	(CH ₂) ₂ O	F + T	11	870
Ethylene Oxide/Propylene Oxide Mixture With Ethylene Oxide content of not more than 30% by weight	(CH ₂)O ₂ + CH ₃ CHOCH ₂	F + T	27	830
Isoprene(inhibited)	CH ₂ C(CH ₃)CHCH ₂	F	34.0	680
Isopropylamine	(CH ₃) ₂ CH N H ₂	F + T	33.0	670
Methane (LNG)	CH ₄	F	-163	420
Methyl Acetylene -Propadiene mixture		F		620
Methyl Bromide	CH ₃ Br	F + T	4	1730
Methyl Chloride	CH ₃ Cl	F + T	-24.0	970
Monoethylamine	C ₂ H ₃ NH ₂	F + T	16.6	690
Nitrogen	N ₂	O	-196	808
Pentanes (all Isomers)	CH ₃ (CH ₂) ₃ CH ₃	F	29 to 36	626
Pentene (all Isomers)	CH ₃ CH ₂ CH ₂ CH=CH ₂	F	30 to 37	656
Propane	C ₃ H ₈	F	-42.3	590
Propylene	C ₃ H ₆	F	-47.7	610
Propylene Oxide	CH ₃ CHOCH ₂	F + T	+33.9	822
Refrigerant gases			3.6 to -81.4	1410 to 1526
Sulphur Dioxide	SO ₂	T	-10	1460
Vinyl Chloride Monomer (VCM)	CH ₂ CHCl	F + T	-13.9	970
Vinyl Ethyl Ether	CH ₂ -CHOC ₂ H ₅	F + T	35.5	750
Vinylidene Chloride	C ₂ H ₂ -CCl ₂	F + T	31.7	1250

Note:

F – flammable vapor detection

T – toxic vapor detection

CHAPTER 3 Structural Design Requirements

SECTION 2 General Requirements

1 General Requirements

1.1 General

The design and construction of the ship-shape or barge-shaped hull, hull interface structure, independent cargo tanks including the structure supporting the cargo tanks of floating offshore liquefied gas terminals are to be based on the applicable requirements of this Guide and where referenced in the *Marine Vessel Rules*. This Guide reflects the different structural performance and demands expected for a terminal transiting and being positioned at a particular site on a long-term basis compared to that of a vessel engaged in unrestricted seagoing service.

The design criteria for offshore floating liquefied gas terminals are applicable to floating terminals of 150 meters (492 feet) or more in length. In addition, the applicable criteria contained in the IGC Code and the Load Line and SOLAS Conventions issued by the International Maritime Organization are to be considered. It is further suggested that the local authorities having jurisdiction where the floating terminal is to operate be contacted to obtain any further criteria that are applicable to the floating terminal.

The design criteria are applied in two phases. In the first phase, initial design scantlings of the structural hull design are selected, considering nominal, maximum expected loadings that a component is likely to experience in its lifetime for the full ocean service. This phase is called the Initial Scantling Evaluation (ISE) and is governed by the criteria contained in Section 3-4. A second phase requires structural analyses of major portions of the hull structure to verify the adequacy of the structural system's performance, including strength checks for failure modes associated with yielding, buckling and ultimate strength. This phase is referred to as the Total Strength Assessment (TSA) and is governed by the criteria specified in Section 3-5.

The Total Strength Assessment must also consider the interface between the position mooring system and the hull structure and the interface between deck-mounted (or above-deck) equipment modules and the hull structure. The interface structure is defined as the attachment zone of load transmission between the main hull structure and hull mounted equipment, including the position mooring system. The analysis of the hull interface structure is to be performed using direct calculation of local 3-D hull interface finite element models and acceptance criteria as described in Section 3-7.

The strength requirements of the hull structure specified in the ISE phase and the structural analyses and strength assessments of the hull structure required in the TSA phase are based on net scantlings. In determining the required scantlings and performing structural analyses and strength assessments of the hull

structure, the nominal design corrosion values given in 3-2/3.1 TABLE 1 are to be deducted. The strength requirements for independent tanks are based on gross scantlings. The requirements related to Type A independent cargo tanks apply only to where non-corrosive cargoes are carried. If corrosive cargoes are carried in these tanks, the scantlings are to be suitably increased or an effective method of corrosion control is to be adopted.

Owner's extra scantlings (i.e., Owner's specified additional thickness), as included in the vessel's design specifications, are not to be used in the evaluation.

Performance of additional structural analyses can lead to the granting of the optional **DLA** classification notation, which signifies that the design meets the Dynamic Load Approach criteria. Also, the optional **SFA** classification notation can be granted, which signifies that the design satisfies fatigue strength criteria based on Spectral Fatigue Analysis.

The application of the design criteria to reflect the site-dependent nature of the floating terminal is accomplished through the introduction of a series of Environmental Severity Factors (ESFs). Reference is to be made to 3-3/1.1 and Appendix 3-A3 for the applicable structural design and analysis criteria that have been modified to reflect site-specific service conditions.

1.3 Initial Scantling Requirements (1 September 2012)

The initial thickness of plating, the section modulus of longitudinals/stiffeners, and the scantlings of the main supporting structures of the hull structure are to be determined in accordance with the initial scantling criteria of Section 3-4 for the "net" scantlings. These "net" scantling values are to be used in the total strength assessment as required in the following paragraph and Section 3-5. The relevant nominal design corrosion values given in 3-2/3.1 FIGURE 1A and 3-2/3.1 FIGURE 1B and 3-2/3.1 TABLE 1 are then added to the net scantlings to obtain the full scantling requirements.

1.5 Strength Assessment - Failure Modes

A total strength assessment of the structures, determined on the basis of the initial strength criteria in Section 3-4 is to be carried out in accordance with Section 3-5 against the following four failure modes:

1.5.1 Material Yielding

The calculated stress intensities are not to be greater than the yielding state limit given in 3-5/3.1 for all load cases specified in 3-3/9.

1.5.2 Buckling and Ultimate Strength

For each individual member, plate or stiffened panel, the buckling and ultimate strength is to be in compliance with the requirements specified in 3-5/5. In addition, the hull girder ultimate strength is to be in accordance with 3-4/3.9 and Appendix 3-A4.

1.5.3 Fatigue

The fatigue strength of structural details and welded joints in highly stressed regions is to be analyzed in accordance with 3-5/7.

1.5.4 Hull Girder Ultimate Strength

The hull girder ultimate longitudinal bending capacities for either hogging or sagging conditions are to be evaluated in accordance with Appendix 3-A4. The hull girder ultimate bending capacity for the design environmental condition (DEC) is to satisfy the limit state specified in 3-4/3.9.

1.7 Structural Redundancy and Residual Strength

Consideration should be given to structural redundancy and hull girder residual strength in the early design stages.

1.9 Strength Against Blast Loads

The design of the hull against blast overpressure shall be evaluated to check that the hull sustains only local damage, which is not detrimental to the integrity of the whole floating terminal unit at least for the period of evacuation. The hull compartment design shall consider potential for containing damage within the same compartment and eliminate the chain of events leading to spreading the damage to adjacent compartments or to deck, so that significant loss of buoyancy and instability of the overall floating terminal unit and failure of the mooring system is not compromised. The upper hull design shall account for impact of fire events from topsides with potential of deteriorating structural capacity of the hull and thereby reducing stability.

Guidance on fire and blast load considerations and assessments can be found in API Recommended Practice for the Design of Offshore Facilities Against Fire and Blast Loading (API RP2FB).

3 Net Scantlings and Nominal Design Corrosion Values

3.1 General (1 September 2012)

As indicated in 3-2/1.1, the strength criteria specified in this Guide are based on a "net" scantling approach.

The "net" thickness or scantlings correspond to the minimum strength requirements acceptable for classification, regardless of the design service life of the floating terminal. In addition to the coating protection specified in the *Marine Vessel Rules* for all ballast tanks, nominal design corrosion values for plating and structural members as given in 3-2/3.1 TABLE 1 and 3-2/3.1 FIGURE 1A and 3-2/3.1 FIGURE 1B are to be added to the net scantlings. These nominal design corrosion values are intended for a design service life of 20 years. Where the design life is greater than 20 years, the nominal design corrosion values of the hull structure are to be increased in accordance with 3-2/3.3. These nominal design corrosion values are being introduced solely for the above purpose, and are not to be construed as renewal standards.

In view of the anticipated higher corrosion rates for structural members in some regions, such as highly stressed areas, additional design margins should be considered for the primary and critical structural members to minimize repairs and maintenance costs. The beneficial effects of these design margins on reduction of stresses and increase of the effective hull girder section modulus can be appropriately accounted for in the design evaluation.

FIGURE 1A
Nominal Design Corrosion Values

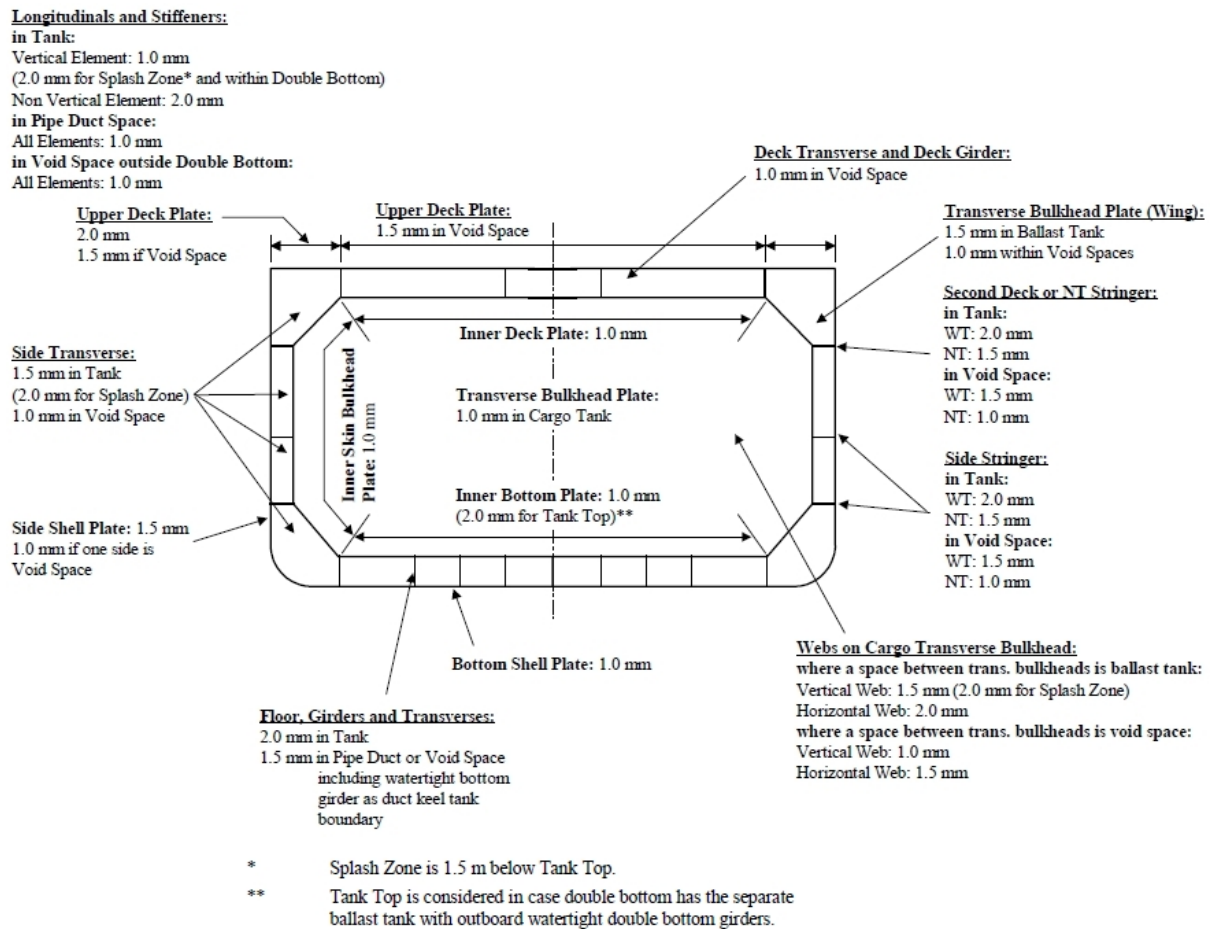

FIGURE 1B
Nominal Design Corrosion Values (1 September 2012)

NDCV same as Figure 1A, except as noted

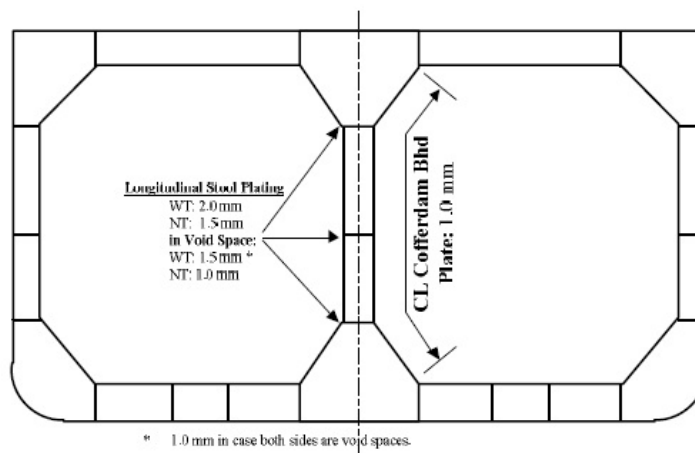

FIGURE 1C
Nominal Design Corrosion Values

NDCV same as Figure 1A, except as noted

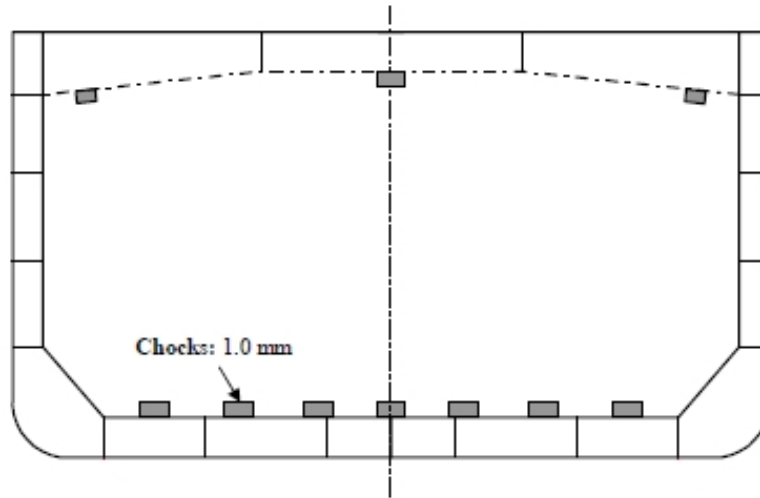

FIGURE 1D
Nominal Design Corrosion Values

NDCV same as Figure 1A, except as noted

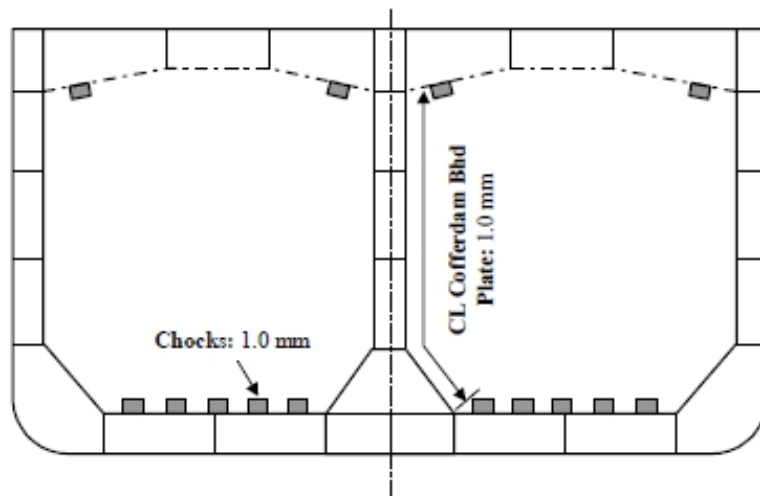

TABLE 1
Nominal Design Corrosion Values ^(1,2) (1 September 2012)

<i>Structural Element/Location</i>		<i>Nominal Design Corrosion Values in mm (in.)</i>	
		<i>in Tank</i>	<i>in Void Space</i>
Upper Deck Plating	Watertight	2.0 (0.08)	
	Void space	1.5 (0.06)	
Inner Deck Plating		1.0 (0.04)	
Side Shell Plating		1.5 (0.06)	

<i>Structural Element/Location</i>		<i>Nominal Design Corrosion Values in mm (in.)</i>	
		<i>in Tank</i>	<i>in Void Space</i>
Bottom Plating		1.0 (0.04)	
Inner Bottom Plating		1.0 (0.04) ⁽³⁾	1.0 (0.04)
Longitudinal Bulkhead Plating		1.0 (0.04)	
Transverse Bulkhead Plating	in Wing Spaces	1.5 (0.06)	1.0 (0.04) ⁽⁸⁾
	in Cargo Tanks	1.0 (0.04)	
Deck Transverse and Deck Girder		N.A.	1.0 (0.04) ⁽⁸⁾
Double Bottom Floor and Girder ⁽⁹⁾		2.0 (0.08)	1.5 (0.06) ⁽⁸⁾
Side Transverse		1.5 (0.06) ⁽⁴⁾	1.0 (0.04)
Side Stringer	Watertight	2.0 (0.08)	1.5 (0.06) ⁽⁸⁾
	Nontight	1.5 (0.06)	1.0 (0.04)
Longitudinal Stool Plating in Centerline Cofferdam Bulkhead	Watertight	2.0 (0.08)	1.5 (0.06) ⁽⁸⁾
	Nontight	1.5 (0.06) ⁽¹⁰⁾	1.0 (0.04)
Webs on Cargo Transverse Bulkhead	Vertical Web	1.5 (0.06) ⁽⁴⁾	1.0 (0.04) ⁽⁸⁾
	Horizontal Web	2.0 (0.08)	1.5 (0.06) ⁽⁸⁾
Longitudinals and Stiffeners	Vertical Element ⁽⁵⁾	1.0 (0.06) ⁽⁷⁾	1.0 (0.04)
	Non Vertical Element ⁽⁶⁾	2.0 (0.08)	1.0 (0.04)
Longitudinals and Stiffeners within Pipe Duct Space		N.A.	1.0 (0.04)
Longitudinals and Stiffeners in Void Spaces outside Double Bottom		N.A.	1.0 (0.04)

Notes:

- 1 It is recognized that corrosion depends on many factors including coating properties, cargo composition and temperature of carriage, and that actual wastage rates observed may be appreciably different from those given here.
- 2 Pitting and grooving are regarded as localized phenomena and are not covered in this table.
- 3 2.0 mm (0.08 in.) for tank top.
- 4 2.0 mm (0.08 in.) for Splash Zone (1.5 meters down from tank top).
- 5 Vertical elements are defined as elements sloped at an angle greater than 25° to the horizontal line.
- 6 Non vertical elements are defined as elements sloped at an angle less than 25° to the horizontal line.
- 7 2.0 mm (0.08 in.) for Splash Zone and within double bottom.
- 8 When plating forms a boundary between a tank and a void space, the plating NDCV is determined by the tank type.
- 9 1.5 mm (0.06 in.) for duct keel tank boundary girder.
- 10 (1 September 2012) 1.0 mm (0.04 in.) when both sides are void spaces (in the case of independent tanks).

3.3 Nominal Design Corrosion Values for Design Life Greater than 20 Years (1 September 2012)

When the structural design life is greater than 20 years, the nominal design corrosion values (NDCV) of the hull structure are to be increased from those in 3-2/3.1 TABLE 1 as follows:

- i)* For plating and structural members with 2.0 mm NDCV for 20-years design life, additional 0.1 mm per year for design life greater than 20-years (for example, 2.5 mm NDCV for 25-year design life).
- ii)* For plating and structural members with 1.5 mm NDCV for 20-years design life, additional 0.075 mm per year for design life greater than 20-years (for example, 1.875 mm NDCV for 25-year design life).
- iii)* For plating and structural members with 1.0 mm NDCV for 20-years design life, additional 0.05 mm per year for design life greater than 20-years (for example, 1.25 mm NDCV for 25-year design life).
- iv)* For Void spaces, no change in NDCV as it is considered independent of design life.

The NDCV values are to be considered minimum nominal design corrosion values. Actual corrosion could be more or less than the NDCV values. The designer or owner may specify additional design corrosion margins based on maintenance plans.

Note:

Local allowable wastage allowance of plates and stiffeners for floating terminals designed for uninterrupted operation on-site without any drydocking and having a design life longer than 20 years is described in 4-2/5.5.2.iii.

The rounding of the calculated thickness is to be the nearest half millimeter. For example:

- For $10.75 \leq t_{calc} < 11.25$ mm, the required thickness is 11 mm
- For $11.25 \leq t_{calc} < 11.75$ mm, the required thickness is 11.5 mm

When the difference between the required net thickness and the offered net thickness is less than 0.25 mm, the offered net thickness is acceptable if the rounded required gross thickness is smaller or equal to the offered gross thickness. For example, the calculated required net thickness is 11.27 mm with a nominal design corrosion margin of 1.25 mm based on a 25 year design life. Then the rounded required net thickness is 11.5 mm. The offered gross thickness is 12.5 mm, therefore the offered net thickness is 11.25 mm (12.5 mm – 1.25 mm). The calculated required gross thickness is 12.52 mm (11.27 mm + 1.25 mm) and the rounded required gross thickness is 12.5 mm. The offered net thickness of 11.25 mm is therefore acceptable, rather than the rounded required net thickness of 11.5 mm.

CHAPTER 3 Structural Design Requirements

SECTION 3 Load Criteria

1 General

1.1 The Concept and Application of Environmental Severity Factors

Floating liquefied gas terminals (FLGT) are sited at locations in which the dynamic components of their loading may be less than those arising from unrestricted service conditions for seagoing trading ships. To adjust the loadings and load effects produced by the site-specific long-term environment at the FLGT site (compared to the full ocean service), a series of "Environmental Severity Factors" (ESFs) have been derived. There are two types of ESFs, which are referred to as "Alpha" type (α) and "Beta" type (β). The α factors are used to adjust fatigue strength performance expectations between the full ocean service and the long-term site-specific environment. The β factors are used primarily to adjust the dynamic component of loads that are used to establish: hull girder strength (i.e., wave-induced hull girder loads), individual scantling design equations, the loads used in the strength analyses of the hull, and ancillary forces, such as those from the motion of equipment masses located on or above the main deck. In practice, the hull may be loaded over a large range of tank loading patterns and external drafts. The implied value of all ESFs of both the alpha and beta types for the full ocean service is 1.0.

The determination of the environmental severity factors is to be carried out in accordance with Appendix 3-A3 using the ABS Eagle FLGT SEAS program.

1.3 Load Components

In the design of the hull structure, all load components with respect to the hull girder and local structure as specified in this Guide and Section 3-2-1 of the *Marine Vessel Rules* are to be taken into account. These include static loads in still water, wave-induced motions and loads, sloshing, slamming, dynamic, thermal and ice loads where applicable.

3 Static Loads

3.1 Still-water Bending Moment and Shear Force

To assess the yielding and buckling strength of the hull structure, the standard design load cases described in this Section are to be analyzed. For still-water bending moment and shear force calculations see 3-4/3.1 of this Guide, and 3-2-1/3.3 and 3-2-1/3.9 of the *Marine Vessel Rules*.

When a direct calculation of wave-induced loads [i.e., longitudinal bending moment and shear forces, hydrodynamic pressures (external) and inertia forces and added pressure heads (internal)] is not submitted,

envelope curves of the still-water bending moments (hogging and sagging) and shear forces (positive and negative), are to be provided.

Except for special loading cases, the loading patterns shown in 3-3/3.3 FIGURE 1A for single center cargo tank arrangement and 3-3/3.3 FIGURE 1B for two cargo tanks abreast arrangement are to be considered in determining local static loads. Loading patterns representing a repair condition where it is assumed a cargo or ballast tank is empty (being repaired) with surrounding tanks or spaces also empty are implicitly included in the loading patterns shown in 3-3/3.3 FIGURE 1A and 3-3/3.3 FIGURE 1B. The one exception where it is explicitly included is for the case of a single center cargo tank under repair, as shown in 3-3/3.3 FIGURE 1A, RLC 1.

3.3 Additional Special Loading Patterns for Independent Cargo Tanks

To assess the yielding and buckling strength of independent cargo tank structures and their supports, additional static standard design load cases are to be analyzed. These special load cases (SLC) can be categorized into the following groups:

- One side of tank loaded condition (SLC1 in 3-3/5.9.3 TABLE 1C)
- Flooded load case for transverse bulkhead (SLC2 in 3-3/5.9.3 TABLE 1C)
- Accidental load cases for supports and chocks (SLC3 ~ SLC5 in 3-3/5.9.3 TABLE 1C)

The special loading patterns are shown in 3-3/3.3 FIGURE 1C.

FIGURE 1A
Loading Pattern

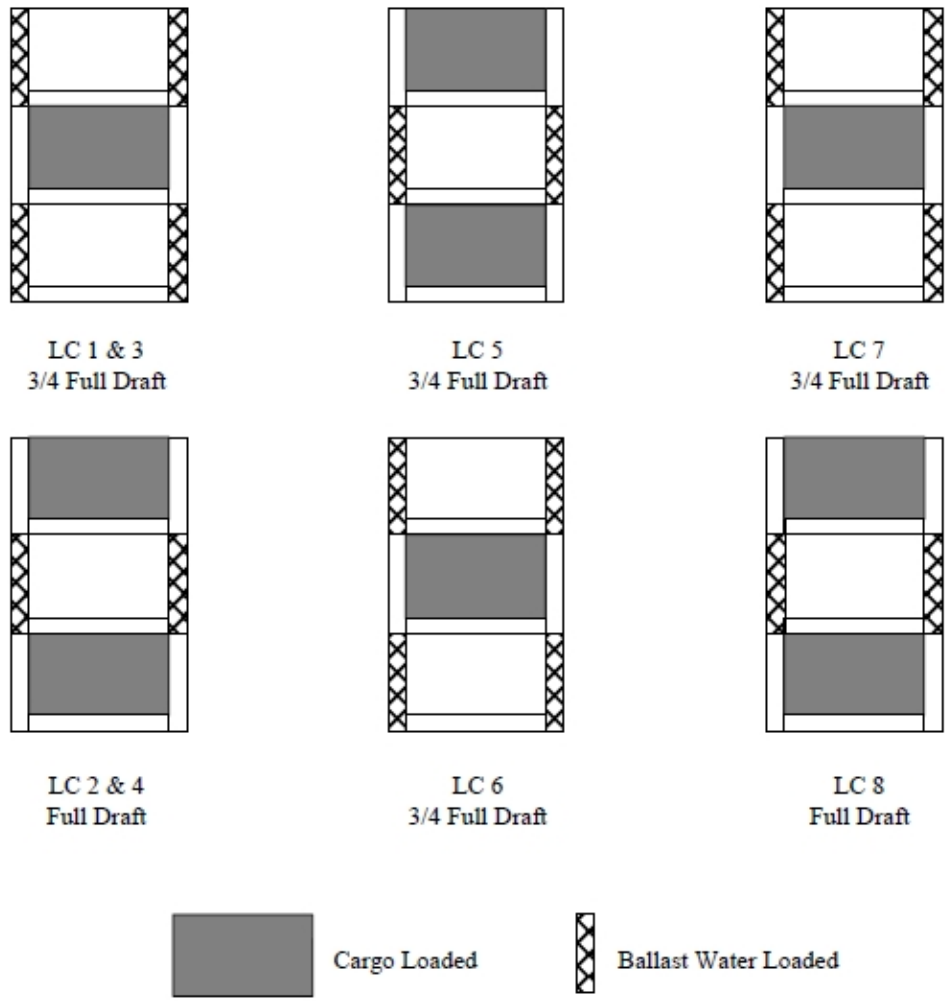

For detailed loading information, see 3/Table 1.

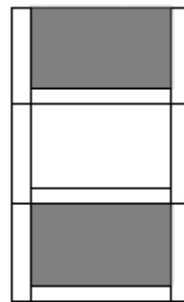

RLC 1 - Repair Condition
 3/4 Full Draft

FIGURE 1B
Loading Pattern

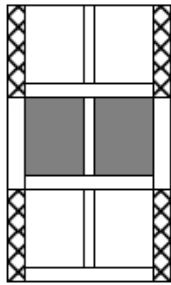

L.C. 1 & 3
3/4 Full Draft

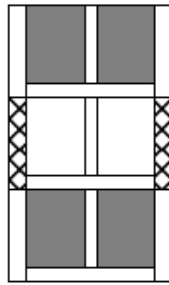

L.C. 5
3/4 Full Draft

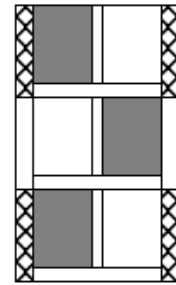

L.C. 7
3/4 Full Draft

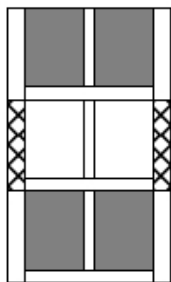

L.C. 2 & 4
Full Draft

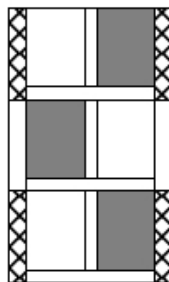

L.C. 6
3/4 Full Draft

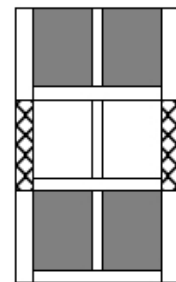

L.C. 8
Full Draft

FIGURE 1C
Special Loading Patterns for Independent Cargo Tanks

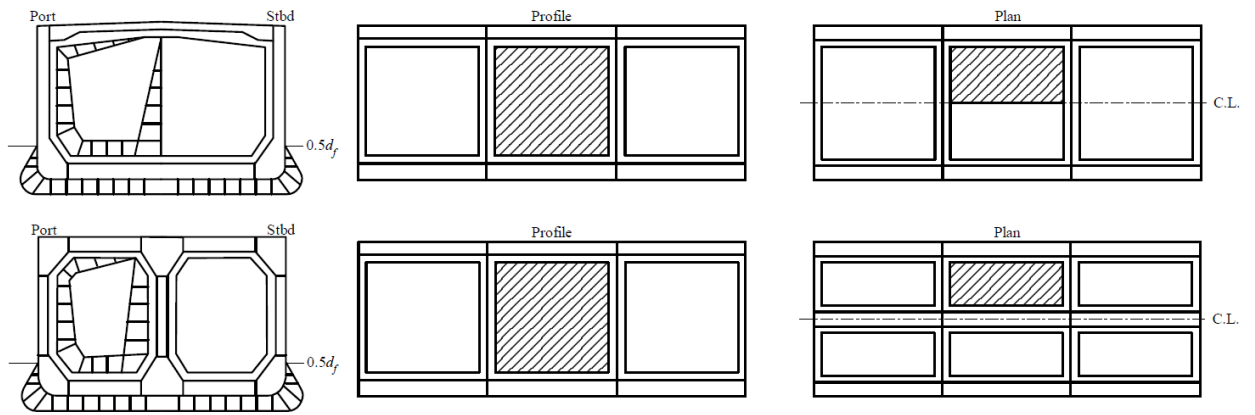

SLC 1

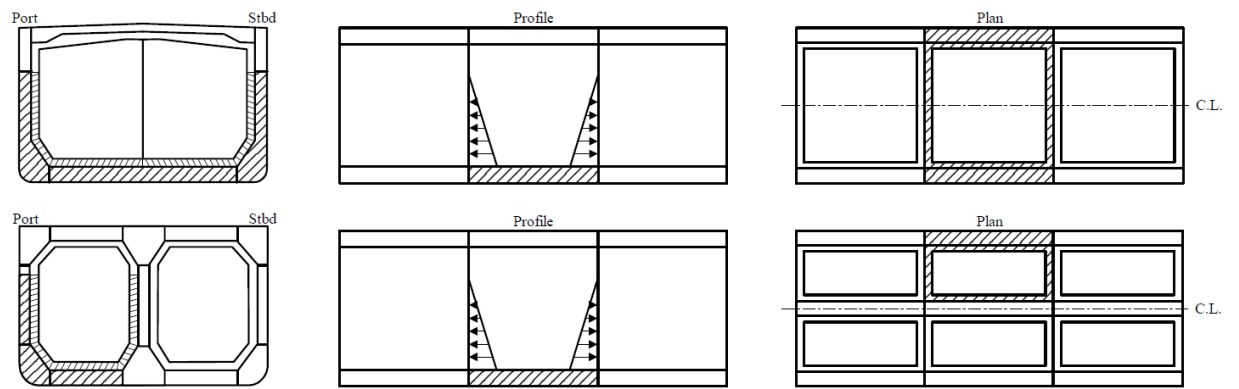

SLC 2

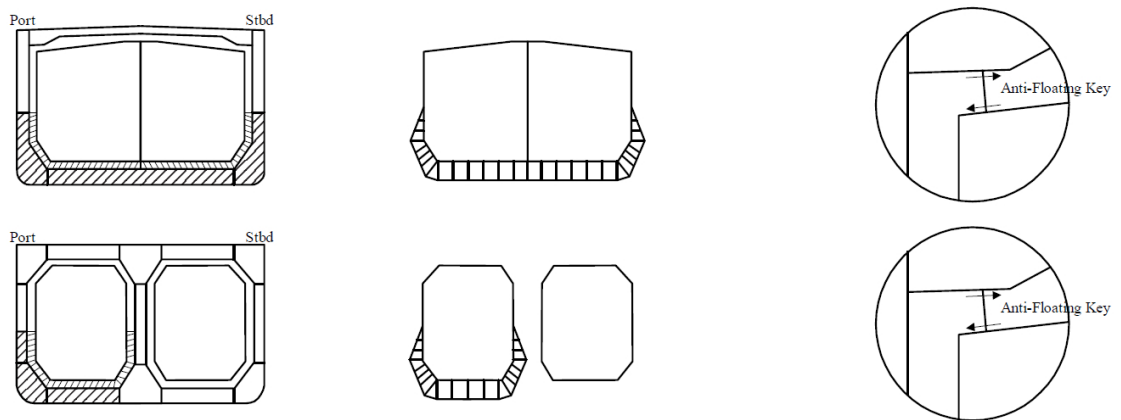

SLC 3

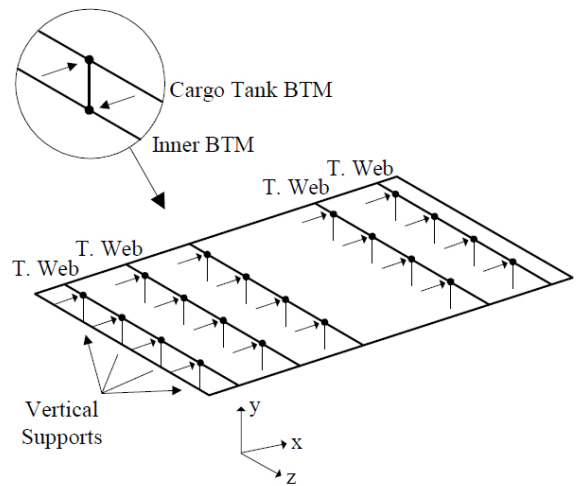
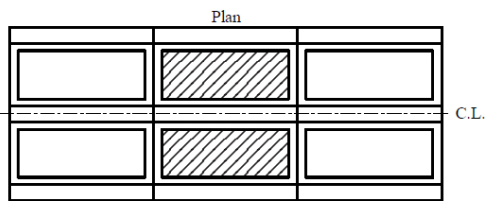
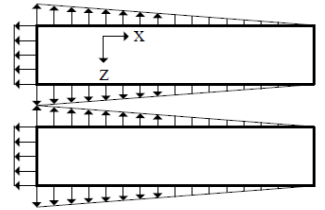
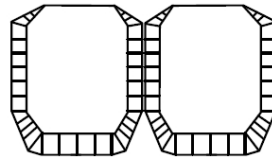
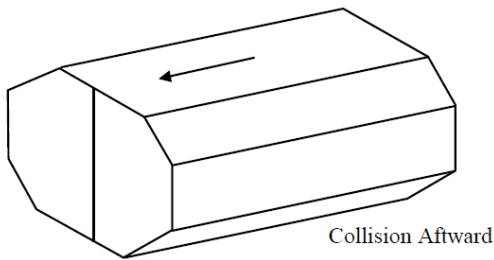
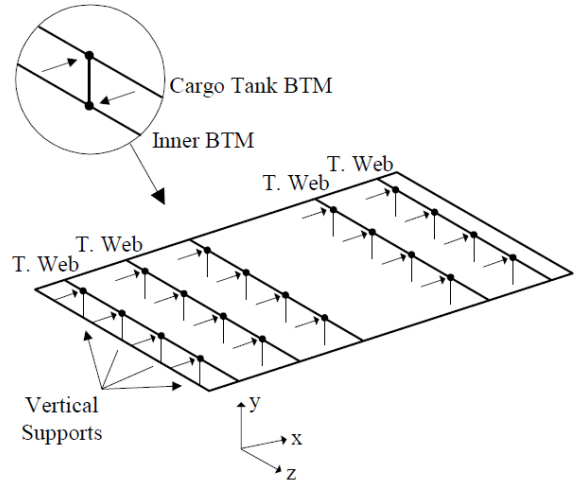
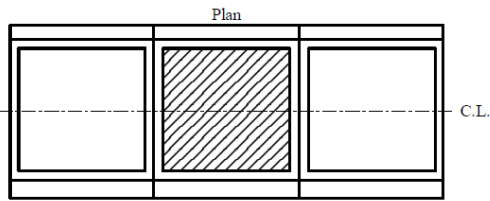
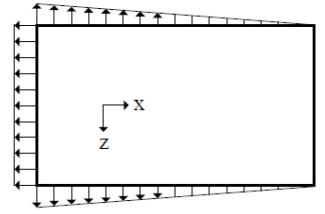
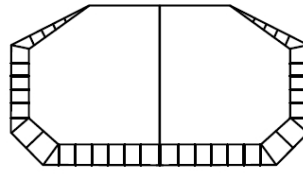
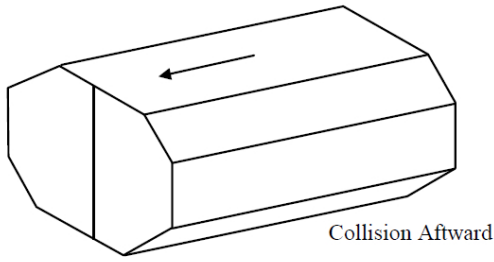

SLC 4

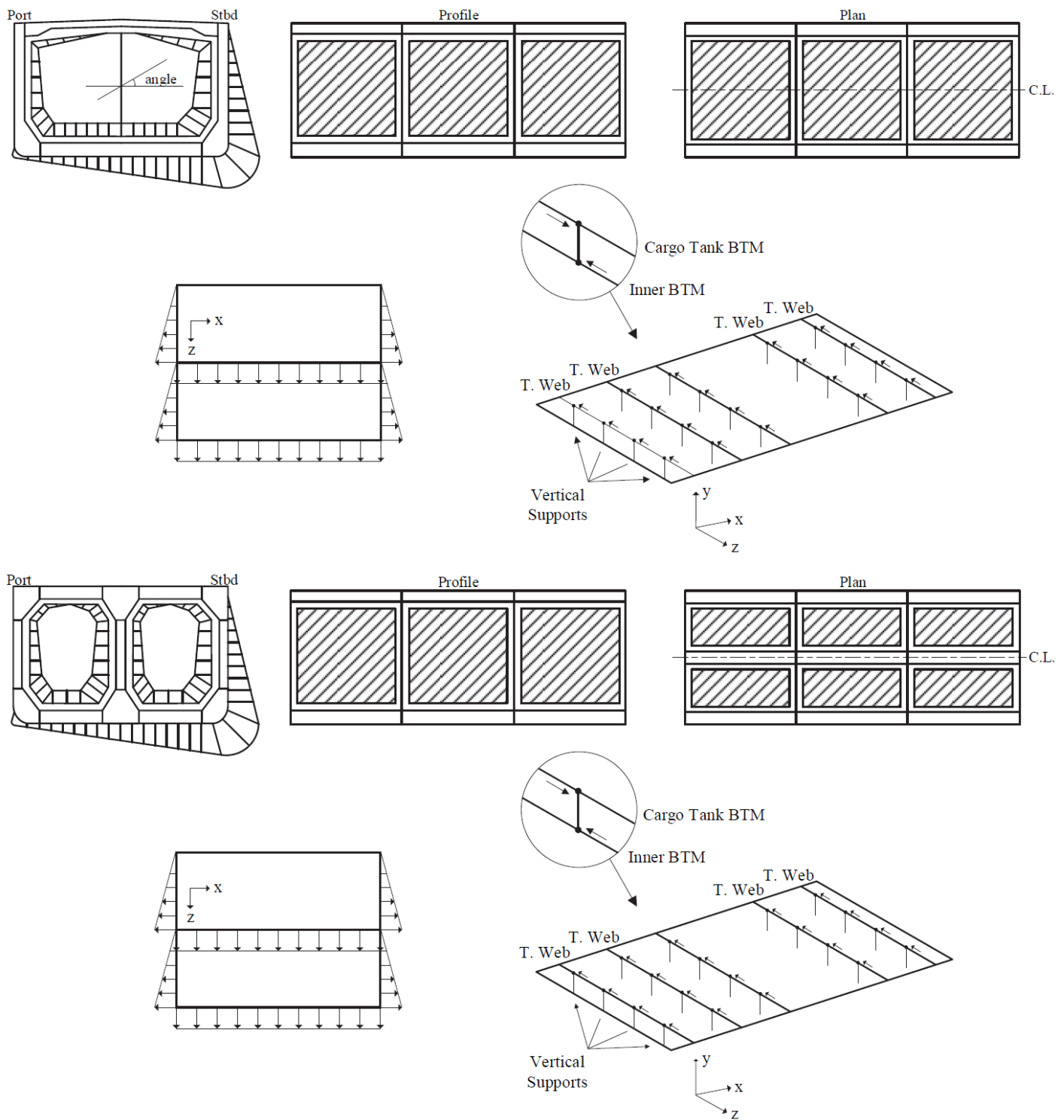

SLC 5

5 Wave-Induced Loads

Where a direct calculation of the wave-induced loads is not available, the approximation equations given below may be used to calculate the design loads.

When a direct calculation of the wave-induced loads is performed, envelope curves of the combined wave and still-water bending moments and shear forces, covering all the anticipated loading conditions, are to be submitted for review.

5.1 Wave-Induced Longitudinal Bending Moments and Shear Forces

5.1.1 Vertical Wave Bending Moments Amidships

The wave bending moment, expressed in kN-m (tf-m, Ltf-ft), may be obtained from the following equations.

$$M_{ws} = -k_1 \beta_{VBM} C_1 L^2 B (C_b + 0.7) \times 10^{-3} \quad \text{Sagging Moment}$$

$$M_{wh} = +k_2 \beta_{VBM} C_1 L^2 B C_b \times 10^{-3} \quad \text{Hogging Moment}$$

where

$$k_1 = 110 \text{ (11.22, 1.026)}$$

$$k_2 = 190 \text{ (19.37, 1.772)}$$

$$\beta_{VBM} = \text{ESF for vertical bending moment, as defined in Appendix 3-A3}$$

$$C_1 = 10.75 - \left(\frac{300-L}{100}\right)^{1.5} \quad 90 \leq L \leq 300 \text{ m}$$

$$= 10.75 \quad 300 < L \leq 350 \text{ m}$$

$$= 10.75 - \left(\frac{L-350}{150}\right)^{1.5} \quad 350 \leq L \leq 500 \text{ m}$$

$$= 10.75 - \left(\frac{984-L}{328}\right)^{1.5} \quad 295 \leq L \leq 984 \text{ ft}$$

$$= 10.75 \quad 984 < L < 1148 \text{ ft}$$

$$= 10.75 - \left(\frac{L-1148}{492}\right)^{1.5} \quad 1148 \leq L \leq 1640 \text{ ft}$$

$$L = \text{length of vessel, as defined in 3-1-1/3.1 of the } \textit{Marine Vessel Rules}, \text{ in m (ft)}$$

$$B = \text{breadth of vessel, as defined in 3-1-1/5 of the } \textit{Marine Vessel Rules}, \text{ in m (ft)}$$

$$C_b = \text{block coefficient, as defined in 3-1-1/13.3 of the } \textit{Marine Vessel Rules}$$

5.1.2 Envelope Curve of Wave Bending Moment

The wave bending moment along the length, L , of the vessel, may be obtained by multiplying the midship value by the distribution factor, M , given in 3-3/5.3.2 FIGURE 2A.

5.1.3 Vertical Wave Shearing Forces

The envelopes of the maximum wave induced shearing forces, F_w , expressed in kN (tf, Ltf), may be obtained from the following equations:

$$F_{wp} = +k\beta_{VSF} F_1 C_1 L B (C_b + 0.7) \times 10^{-2} \quad \text{for positive shear force}$$

$$F_{wn} = -k\beta_{VSF} F_2 C_1 L B (C_b + 0.7) 10^{-2} \quad \text{for negative shear force}$$

where

$$F_{wp}, F_{wn} = \text{maximum shearing force induced by wave, in kN (tf, Ltf)}$$

$$C_1 = \text{as defined in 3-3/5.1.1}$$

- β_{VSF} = ESF for vertical shear force, as defined in Appendix 3-A3
- L = length of vessel, as defined in 3-1-1/3.1 of the *Marine Vessel Rules*, in m (ft)
- B = breadth of vessel, as defined in 3-1-1/5 of the *Marine Vessel Rules*, in m (ft)
- C_b = block coefficient, as defined in 3-1-1/13.3 of the *Marine Vessel Rules*
- k = 30 (3.059, 0.2797)
- F_1 = distribution factor, as shown in 3-3/5.3.2 FIGURE 3A
- F_2 = distribution factor, as shown in 3-3/5.3.2 FIGURE 3B

5.3 Horizontal Wave Bending Moments and Shear Forces

5.3.1 Horizontal Wave Bending Moments

The horizontal wave bending moments, positive (tension port) and negative (tension starboard), may be obtained from the following equation:

$$M_H = \pm m_h \beta_{HBM} K_3 C_1 L^2 D C_b \times 10^{-3} \quad \text{kN-m (tf-m, Ltf-ft)}$$

where

- m_h = distribution factor obtained from 3-3/5.3.2 FIGURE 2B
- β_{HBM} = ESF for horizontal bending moment, as defined in Appendix 3-A3
- K_3 = 180 (18.34, 1.68)
- D = hull depth of floating terminal, in m (ft), as defined in 3-1-1/7.1 of the *Marine Vessel Rules*

C_1 , L , and C_b are as given in 3-2-1/3.5 of the *Marine Vessel Rules*.

5.3.2 Horizontal Wave Shear Force

The envelope of horizontal wave shearing force, F_H , expressed in kN (tf, Ltf), positive (toward port forward) or negative (toward starboard aft), may be obtained from the following equation:

$$F_H = \pm f_h \beta_{HSF} k C_1 L D (C_b + 0.7) \times 10^{-2} \quad \text{kN (tf, Ltf)}$$

where

- f_h = distribution factor, as given in 3-3/5.3.2 FIGURE 3C
- β_{HSF} = ESF for horizontal shear force, as defined in Appendix 3-A3
- k = 36 (3.67, 0.34)

C_1 , L , D and C_b are as defined in 3-3/5.3.1 above.

FIGURE 2A
Distribution Factor M

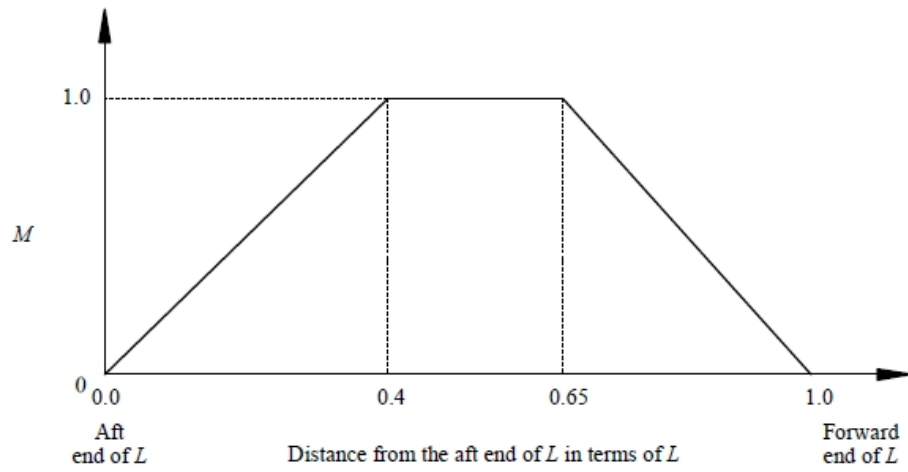

FIGURE 2B
Distribution Factor m_h

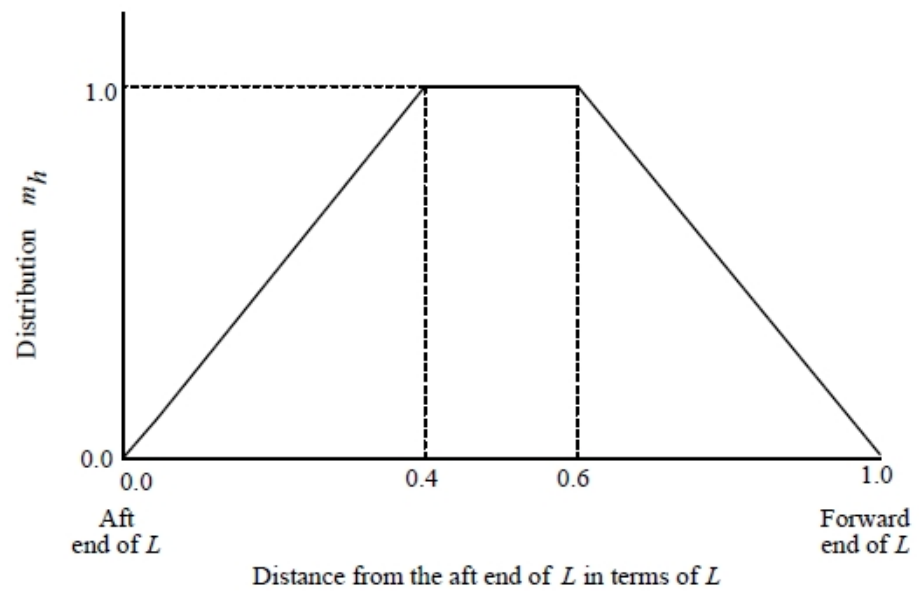

FIGURE 3A
 Distribution Factor F_1

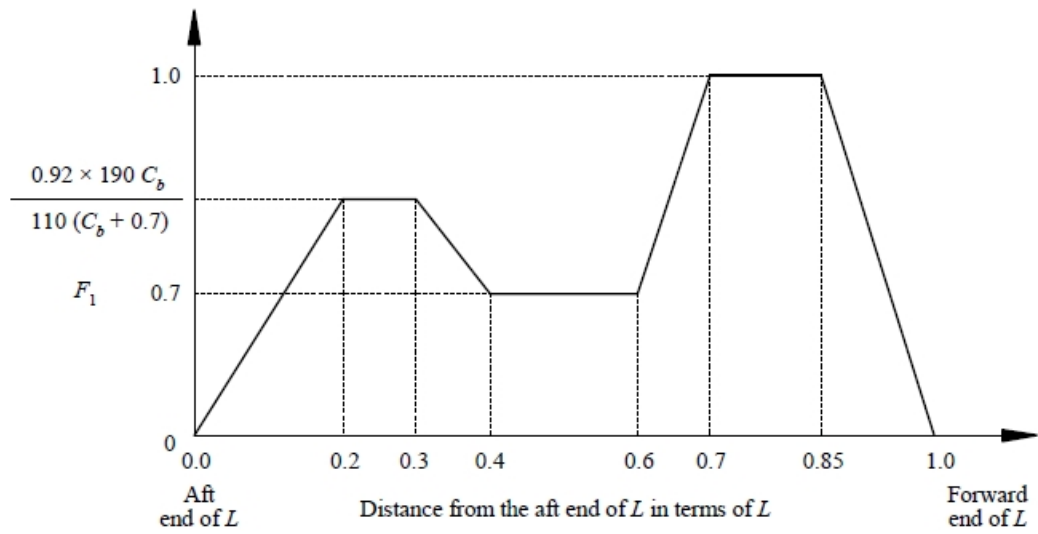

FIGURE 3B
 Distribution Factor F_2

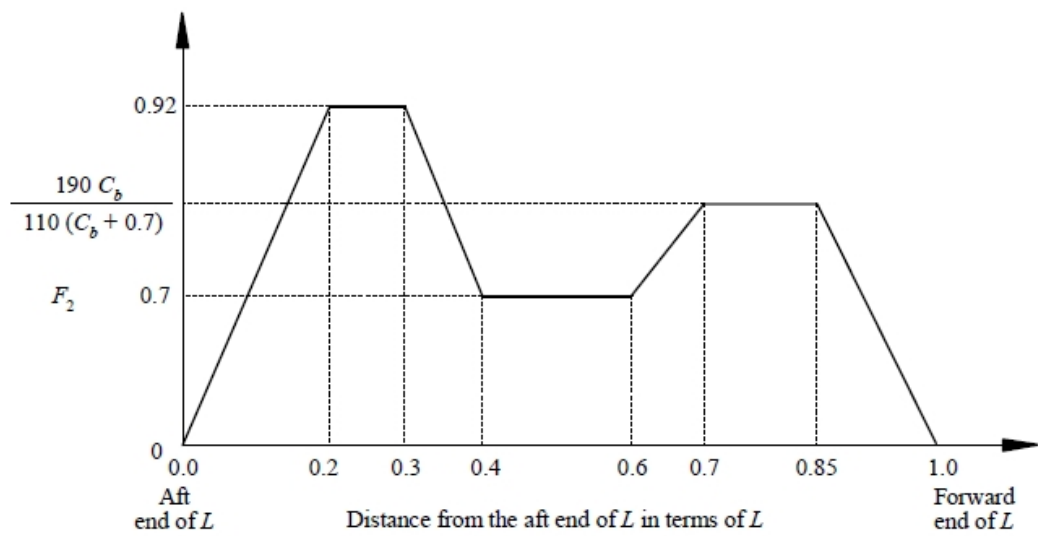
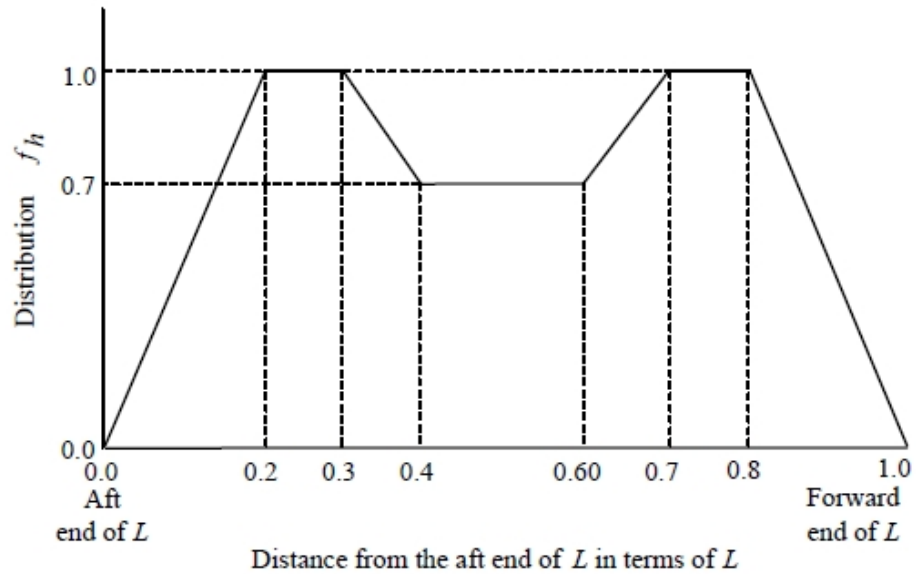

FIGURE 3C
Distribution Factor f_h



5.5 External Pressures

5.5.1 Pressure Distribution

The external pressures, p_e , (positive toward inboard), imposed on the hull in seaways can be expressed by the following equation at a given location:

$$p_e = \rho g(h_s + \beta_{EPS/EPP} k_u h_{de}) \geq 0 \quad \text{N/cm}^2 \text{ (kgf/cm}^2, \text{ lbf/in}^2\text{)}$$

where

- ρg = specific weight of sea water
 = 1.005 N/cm²-m (0.1025 kgf/cm²-m, 0.4444 lbf/in²-ft)
- h_s = hydrostatic pressure head in still water, in m (ft)
- $\beta_{EPS/EPP}$ = ESF for external pressure starboard/port, as defined in Appendix 3-A3
- k_u = load factor, and may be taken as unity unless otherwise specified
- h_{de} = hydrodynamic pressure head induced by the wave and may be calculated as follows:
 = $k_c h_{di}$ m (ft)
- k_c = correlation factor for a specific combined load case, as given in 3-3/7.3.1 and 3-3/9
- h_i = hydrodynamic pressure head at location i ($i = 1, 2, 3, 4$ or 5 ; see 3-3/5.9.3 FIGURE 4)
 = $k_\ell \alpha_i h_{do}$ m (ft)
- k_ℓ = distribution factor along the length of the vessel
 = $1 + (k_{\ell o} - 1) \cos \mu$, $k_{\ell o}$ is as given in 3-3/5.9.3 FIGURE 5
 = 1.0 amidships

α_i	=	distribution factor around the girth of vessel at location i
	=	$1.00 - 0.25 \cos \mu$ for $i = 1$, at WL, starboard
	=	$0.40 - 0.10 \cos \mu$ for $i = 2$, at bilge, starboard
	=	$0.30 - 0.20 \sin \mu$ for $i = 3$, at bottom centerline
	=	$2\alpha_3 - \alpha_2$ for $i = 4$, at bilge, port
	=	$0.75 - 1.25 \sin \mu$ for $i = 5$, at WL, port
		α_i at intermediate locations of i may be obtained by linear interpolation.
μ	=	wave heading angle, to be taken from 0° to 90° (0° for head sea, 90° for beam sea for wave coming from starboard)
h_{do}	=	$1.36 kC_1$ m (ft)
k	=	1 (1, 3.281)
C_1	=	as defined in 3-3/5.3.1

The distribution of the total external pressure including static and hydrodynamic pressure is illustrated in 3-3/5.9.3 FIGURE 6.

5.5.2 Extreme Pressures

In determining the required scantlings of local structural members, the extreme external pressure, p_e , to be used, is as defined in 3-3/5.5.1 with k_u as given in 3-3/7 and 3-3/9.

5.5.3 Simultaneous Pressures

When performing 3D structural analysis, the simultaneous pressure along any portion of the hull girder may be obtained from:

$$p_{es} = \rho g (h_s + \beta_{EPS/EPP} k_f k_u h_{de}) \geq 0 \quad \text{N/cm}^2 \text{ (kgf/cm}^2, \text{ lbf/in}^2\text{)}$$

where

$\beta_{EPS/EPP}$	=	ESF for external pressure starboard/port, as defined in Appendix 3-A3
k_f	=	factor denoting the phase relationship between the reference station and adjacent stations considered along the vessel's length, and may be determined as follows:
	=	$k_{fo} \left\{ 1 - \left[1 - \cos \frac{2\pi(x-x_o)}{L} \right] \cos \mu \right\}$
k_{fo}	=	± 1.0 , as specified in 5.9.3 TABLE 1.
x	=	distance from A.P. to the station considered, in m (ft)
x_o	=	distance from A.P. to the reference station*, in m (ft)
	Note:	* The reference station is the point along the vessel's length where the wave trough or crest is located and may be taken as the mid-point of the mid-hold of the three hold model.
L	=	scantling length of floating terminal, in m (ft), as defined in 3-1-1/3.1 of the <i>Marine Vessel Rules</i>
μ	=	wave heading angle, to be taken from 0° to 90°

ρg , h_s , k_u and h_{de} are as defined in 3-3/5.5.1.

The simultaneous pressure distribution around the girth of the vessel is to be determined based on the wave heading angles specified in 3-3/7 and 3-3/9.

5.7 Internal Pressures - Inertia Forces and Added Pressure Heads

5.7.1 Floating Terminal Motions and Accelerations

To determine the inertial forces and added pressure heads for a completely filled cargo or ballast tank, the dominating vessel motions, pitch and roll, and the resultant accelerations induced by the wave are required. When a direct calculation is not available, the equations given below may be used.

5.7.1(a) Pitch.

The pitch amplitude (positive bow up):

$$\phi = \beta_{PMO} k_1 (10/C_b)^{1/4} / L \quad \text{degrees, but need not to be taken greater than } 10^\circ$$

The pitch natural period:

$$T_p = k_2 \sqrt{C_b d_i} \text{ seconds}$$

where

$$\begin{aligned} \beta_{PMO} &= \text{ESF for pitch motion, as defined in Appendix 3-A3} \\ k_1 &= 1030 \text{ (3380)} \quad \text{for } L \text{ in m (ft)} \\ k_2 &= 3.5 \text{ (1.9323)} \quad \text{for } d_i \text{ in m (ft)} \\ d_i &= \text{draft amidships for the relevant loading conditions} \end{aligned}$$

L and C_b are as defined in 3-3/5.3.1.

5.7.1(b) Roll.

The roll amplitude (positive starboard down):

$$\begin{aligned} \theta &= C_R \beta_{RMO} (35 - k_\theta C_{di} \Delta / 1000) && \text{if } T_r > 20 \text{ seconds} \\ \theta &= C_R \beta_{RMO} (35 - k_\theta C_{di} \Delta / 1000) (1.5375 - 0.027 T_r) && \text{if } 12.5 \leq T_r \leq 20 \text{ seconds} \\ \theta &= C_R \beta_{RMO} (35 - k_\theta C_{di} \Delta / 1000) (0.8625 + 0.027 T_r) && \text{if } T_r \leq 12.5 \text{ seconds} \end{aligned}$$

θ in degrees, but need not to be taken greater than 30°

$$\begin{aligned} k_\theta &= 0.005 \text{ (0.05, 0.051)} \\ C_R &= 1.05 \\ \beta_{RMO} &= \text{ESF for roll motion, as defined in Appendix 3-A3} \\ C d_i &= 1.06 (d_i/d_f) - 0.06 \\ d_i &= \text{draft amidships for the relevant loading conditions, m (ft)} \\ d_f &= \text{draft, in m (ft), as defined in 3-1-1/9 of the } \textit{Marine Vessel Rules} \\ \Delta &= k_d L B d_f C_b \text{ kN (tf, Ltf)} \\ k_d &= 10.05 \text{ (1.025, 0.0286)} \\ C_b &= \text{block coefficient, as defined in 3-1-1/13.3 of the } \textit{Marine Vessel Rules}, \text{ but is not to be taken less than } 0.6 \end{aligned}$$

L and B are the length and breadth of the vessel respectively, as defined in Section 3-1-1 of the *Marine Vessel Rules*.

The roll natural motion period:

$$T_r = k_4 k_r / GM^{0.5} \quad \text{seconds}$$

where

$$k_4 = 2 (1.104)$$

$$k_r = \text{roll radius of gyration, in m (ft), and may be taken as } 0.35B \text{ for full load conditions and } 0.45B \text{ for ballast conditions}$$

$$GM = \text{metacentric height, in m (ft), to be taken as:}$$

$$= GM(\text{full}) \quad \text{for full draft}$$

$$= 1.5 GM(\text{full}) \quad \text{for } 3/4 d_f$$

$$= 2.0 GM(\text{full}) \quad \text{for } 2/3 d_f$$

$$GM(\text{full}) = \text{metacentric height for fully loaded condition}$$

) If $GM(\text{full})$ is not available, $GM(\text{full})$ may be taken as $0.12B$ for the purpose of estimation.

5.7.1(c) Accelerations.

The vertical, longitudinal and transverse accelerations, a_v , a_ℓ and a_t , of tank contents (cargo or ballast) may be obtained from the following formulae:

$$a_v = C_v \beta_{VAC} k_v a_o g \quad \text{m/sec}^2 \text{ (ft/sec}^2\text{)} \quad \text{positive downward}$$

$$a_\ell = C_\ell \beta_{LAC} k_\ell a_o g \quad \text{m/sec}^2 \text{ (ft/sec}^2\text{)} \quad \text{positive forward}$$

$$a_t = C_t \beta_{TAC} k_t a_o g \quad \text{m/sec}^2 \text{ (ft/sec}^2\text{)} \quad \text{positive starboard}$$

where

$$a_o = k_o (2.4/L^{1/2} + 34/L - 600/L^2) \quad \text{for } L \text{ in m}$$

$$= k_o (4.347/L^{1/2} + 111.55/L - 6458/L^2) \quad \text{for } L \text{ in ft}$$

$$k_o = 1.38 - 0.47 C_b$$

$$C_v = \cos \beta + (1 + 2.4 z/B) (\sin \beta) / k_v$$

$$\beta = \text{wave heading angle in degrees, } 0^\circ \text{ for head sea, and } 90^\circ \text{ for beam sea for wave coming from starboard}$$

$$\beta_{VAC} = \text{ESF for vertical acceleration, as defined in Chapter 3, Appendix 3}$$

$$\beta_{LAC} = \text{ESF for longitudinal acceleration, as defined in Chapter 3, Appendix 3}$$

$$\beta_{TAC} = \text{ESF for transverse acceleration, as defined in Chapter 3, Appendix 3}$$

$$k_v = [1 + 0.65(5.3 - 45/L)^2 (x/L - 0.45)^2]^{1/2} \quad \text{for } L \text{ in m}$$

$$= [1 + 0.65(5.3 - 147.6/L)^2 (x/L - 0.45)^2]^{1/2} \quad \text{for } L \text{ in ft}$$

$$C_\ell = 0.35 - 5.0(L - 200) 10^{-4} \quad \text{for } L \text{ in m}$$

$$= 0.35 - 1.5(L - 656) 10^{-4} \quad \text{for } L \text{ in ft}$$

$$k_\ell = 0.5 + 8y/L$$

- $C_t = 1.27[1 + 1.52(x/L - 0.45)^2]^{1/2}$
 $k_t = 0.35 + y/B$
 $x =$ longitudinal distance from the A.P. to the station considered, in m (ft)
 $y =$ vertical distance from the waterline to the point considered, in m (ft), positive upward
 $z =$ transverse distance from the centerline to the point considered, in m (ft), positive starboard
 $g =$ acceleration of gravity = 9.8 m/sec² (32.2 ft/sec²)

L and B are the length and breadth of the vessel respectively, as defined in Section 3-1-1 of the *Marine Vessel Rules*, in m (ft).

5.7.2 Internal Pressures

5.7.2(a) Distribution of Internal Pressures.

The internal pressure, (positive toward tank boundaries) for a completely filled tank may be obtained from the following formula:

$$p_i = \rho g(\eta + \Delta\eta + k_u h_d) + p_o \geq 0 \quad \text{N/cm}^2 \text{ (kgf/cm}^2, \text{ lbf/in}^2\text{)}$$

where

- $p_o = (p_{vp} - p_n) \geq 0$ in cargo tank, N/cm² (kgf/cm², lbf/in²)
 $= 0$ in ballast tank
 $p_{vp} =$ pressure setting on pressure/vacuum relief valve ≤ 6.90 N/cm² (0.71 kgf/cm², 10.00 lbf/in²) for integral gravity tanks
 $p_n = 2.50$ N/cm² (0.255 kgf/cm², 3.626 lbf/in²)
 $\rho g =$ specific weight of the liquid, not to be taken less than 0.49 N/cm²-m (0.05 kgf/cm²-m, 0.2168 lbf/in²-ft) for the fluid cargoes and not less than 1.005 N/cm²-m (0.1025 kgf/cm²-m, 0.4444 lbf/in²-ft) for ballast water
 $\eta =$ local coordinate in vertical direction for tank boundaries measuring from the top of the tanks, as shown in 3-3/5.9.3 FIGURE 7B, in m (ft)
 $\Delta\eta = 0$ for the cargo tank and the ballast tank whose tank top extends to the upper deck or the trunk deck
 $=$ a distance equivalent to $2/3$ of the distance from tank top to the top of the overflow (The exposed height is minimum 760 mm above freeboard deck or 450 mm above superstructure deck.) for the lower tank whose tank top does not extend to the upper deck.
 $k_u =$ load factor and may be taken as unity unless otherwise specified
 $h_d =$ wave-induced internal pressure head, including inertial force and added pressure head.
 $= k_c(\eta a_i/g + \Delta h_i)$ in m (ft)
 $k_c =$ correlation factor and may be taken as unity unless otherwise specified
 $a_i =$ effective resultant acceleration at the point considered, and may be approximated by:
 $0.71C_{dp}[w_v a_v + w_\ell(\ell/h)a_\ell + w_t(b/h)a_t]$ m/sec² (ft/sec²)

C_{dp} is specified in 3-3/5.7.2(d).

a_v , a_ℓ and a_t are as given in 3-3/5.7.1(c).

w_v , w_ℓ and w_t are weighted coefficients, showing directions, as specified in 3-3/Tables 1 and 3.

Δh_i = added pressure head due to pitch and roll motions at the point considered, in m (ft),
 may be calculated as follows:

In general, the added head may be calculated based on the vertical distance from the reference point of the tank to the point considered. The reference point is (1) the highest point of the tank boundary after roll and pitch, or (2) the average height of the points, after roll and pitch, which are $\Delta\eta$ above the top of the tank at the overflow, whichever is greater.

For prismatic tanks on starboard side, whose tank top extends to the upper deck or the trunk deck, added pressure head may be calculated as follows:

i) For bow down and starboard down ($\phi_e < 0, \theta_e > 0$)

$$\Delta h_i = \xi \sin(-\phi_e) + C_{ru}(\zeta_e \sin\theta_e \cos\phi_e + \eta_e \cos\theta_e \cos\phi_e - \eta)$$

$$\zeta_e = b - \zeta$$

$$\eta_e = \eta$$

ii) For bow up and starboard up ($\phi_e > 0, \theta_e < 0$)

$$\Delta h_i = (\ell - \xi) \sin\phi_e + C_{ru}(\zeta_e \sin(-\theta_e) \cos\phi_e + \eta_e \cos\theta_e \cos\phi_e - \eta)$$

$$\zeta_e = \zeta - \delta_b$$

$$\eta_e = \eta - \delta_h$$

ξ, ζ, η are the local coordinates, in m (ft), for the point considered with respect to the origin in 3-3/5.9.3 FIGURE 7B.

C_{ru} is specified in 3-3/5.7.2(d).

δ_b and δ_h are the local coordinate adjustments, in m (ft), for the point considered with respect to the origin shown in 3-3/5.9.3 FIGURE 7B.

where

$$\theta_e = 0.71C_\theta\theta$$

$$\phi_e = 0.71C_\phi\phi$$

$$\ell = \text{length of the tank, in m (ft)}$$

$$h = \text{depth of the tank, in m (ft)}$$

$$b = \text{breadth of the tank considered, in m (ft)}$$

ϕ and θ are pitch and roll amplitudes, as given in 3-3/5.7.1(a) and 3-3/5.7.1(b).

C_ϕ and C_θ are weighted coefficients, showing directions as given in 3-3/Tables 1 and 3.

For prismatic lower tanks on starboard side, whose tank top does not extend to the upper deck or the trunk deck, the added pressure head may be calculated as follows assuming the reference point based on the average height of the overflow.

i) For bow down and starboard down ($\phi_e < 0, \theta_e > 0$)

$$\Delta h_i = (\xi - \ell/2)\sin(-\phi_e) + C_{ru}(\zeta_e \sin\theta_e \cos\phi_e + \eta_e \cos\theta_e \cos\phi_e - \eta_e)$$

$$\zeta_e = b_a - \zeta$$

$$\eta_e = \eta + \Delta\eta$$

ii) For bow up and starboard up ($\phi_e > 0, \theta_e < 0$)

$$\Delta h_i = (\ell/2 - \xi)\sin\phi_e + C_{ru}\{\zeta_e \sin(-\theta_e)\cos\phi_e + \eta_e \cos\theta_e \cos\phi_e - \eta_e\}$$

$$\zeta_e = \zeta - b_a$$

$$\eta_e = \eta + \Delta\eta$$

b_a is the transverse distance of over flow from ζ axis. All other parameters are as defined above.

5.7.2(b) *Extreme Internal Pressure.*

For assessing local structures at a tank boundary, the extreme internal pressure with as specified in 3-3/7 is to be considered.

5.7.2(c) *Simultaneous Internal Pressures.*

In performing a 3D structural analysis except for L.C. 9, 10 and 11, the internal pressures may be calculated in accordance with 3-3/5.7.2(a) and 3-3/5.7.2(b) above for tanks in the mid-body. For tanks in the fore or aft body, the pressures should be determined based on linear distributions of accelerations and motions along the length of the vessel.

5.7.2(d) *Definition of Tank Shape and Associated Coefficients*

i) *Rectangular Tank*

The following tank is considered as a rectangular tank:

$$b/b_1 \leq 3.0 \text{ or } h/h_1 \leq 3.0$$

where

b = extreme breadth of the tank considered

b_1 = least breadth of wing tank part of the tank considered

h = extreme height of the tank considered

h_1 = least height of double bottom part of the tank considered, as shown in 3-3/5.9.3
 FIGURE 7A

The coefficients C_{dp} and C_{ru} of the tank are as follows:

$$C_{dp} = 1.0$$

$$C_{ru} = 1.0$$

ii) *J-shaped Tank*

A tank having the following configurations is considered as a “J-shaped” tank.

$$b/b_1 \geq 5.0 \text{ and } h/h_1 \geq 5.0$$

The coefficients C_{dp} and C_{ru} are as follows:

$$C_{dp} = 0.7$$

$$C_{ru} = 1.0$$

iii) In the case where the minimum tank ratio of b/b_1 or h/h_1 , whichever is lesser, is greater than 3.0 but less than 5.0, the coefficient C_{dp} of the tank is to be determined by the following interpolation:

An intermediate tank between rectangular and J-shaped tank:

$$C_{dp} = 1.0 - 0.15 (\text{the lesser of } b/b_1 \text{ or } h/h_1 - 3.0)$$

$$C_{ru} = 1.0$$

5.9 Internal Pressures - IGC Code

The cargo tanks with their supports and other fixtures are to be designed taking into account internal pressure loads based on the *International Code for the Construction and Equipment of Ships Carrying Liquefied Gases in Bulk* (IGC Code). The vessel acceleration and internal pressure formulations of the IGC Code are modified to account for site specific wave environment and to also accommodate two cargo tanks abreast that are arranged along the centerline of the terminal’s hull. The determination of the accelerations and pressures is given in the following paragraphs.

5.9.1 Vessel Accelerations (1 August 2017)

The accelerations acting on tanks are estimated at their center of gravity. a_x , a_y , a_z are the maximum dimensionless accelerations (i.e., relative to the acceleration of gravity) in the longitudinal, transverse and vertical directions, respectively and they are considered as acting separately for calculation purposes. a_z does not include the component due to the static weight, a_y includes the component due to the static weight in the transverse direction due to rolling and a_x includes the component due to the static weight in the longitudinal direction due to pitching. The following formulae are given as guidance for the components of acceleration due to floating offshore gas terminal’s motions corresponding to a probability level at the operating site wave environment, and apply to terminals with a length exceeding 50 m (164 ft). These formulae are based on the accelerations defined in 5C-8-4/28.2 of the *Marine Vessel Rules* and modified by the appropriate ESF β factors.

Vertical acceleration

$$a_z = \pm \beta_{VAC} a_0 \left[\sqrt{1 + \left(5.3 - \frac{45}{L}\right)^2 \left(\frac{x}{L} + 0.05\right)^2 \left(\frac{0.6}{C_B}\right)^{1.5} + \left(\frac{0.6yK^{1.5}}{B}\right)^2} \right] \text{ for } L \text{ in m}$$

$$a_z = \pm \beta_{VAC} a_0 \left[\sqrt{1 + \left(5.3 - \frac{148}{L}\right)^2 \left(\frac{x}{L} + 0.05\right)^2 \left(\frac{0.6}{C_B}\right)^{1.5} + \left(\frac{0.6yK^{1.5}}{B}\right)^2} \right] \text{ for } L \text{ in ft}$$

Transverse acceleration

$$a_y = \pm \beta_{TAC} a_0 \sqrt{0.6 + 2.5 \left(\frac{x}{L} + 0.05\right)^2 + K \left(1 + 0.6K \frac{z}{B}\right)^2}$$

Longitudinal acceleration

$$a_x = \pm \beta_{LAC} a_o \sqrt{0.06 + A^2 - 0.25A}$$

with:

$$A = \left(0.7 - \frac{L}{1200} + 5\frac{z}{L}\right)\left(\frac{0.6}{C_B}\right) \quad \text{for } L \text{ in m}$$

$$= \left(0.7 - \frac{L}{3937} + 5\frac{z}{L}\right)\left(\frac{0.6}{C_B}\right) \quad \text{for } L \text{ in ft}$$

where

- L = scantling length of floating terminal, in m (ft)
- C_B = block coefficient
- B = greatest molded breadth of floating terminal, in m (ft)
- β_{VAC} = ESF for vertical acceleration, as defined in Chapter 3, Appendix 3
- β_{TAC} = ESF for transverse acceleration, as defined in Chapter 3, Appendix 3
- β_{LAC} = ESF for longitudinal acceleration, as defined in Chapter 3, Appendix 3
- x = longitudinal distance from amidships to the center of gravity of the tank with contents, in m (ft); x is positive forward of amidships, negative aft of amidships
- y = transverse distance from vessel's centerline to the center of gravity of the tank with contents, in m (ft); y is positive portside, negative starboard
- z = vertical distance from the terminal's actual waterline to the center of gravity of tank with contents, in m (ft); z is positive above and negative below the waterline.
- a_o = $\frac{2}{\sqrt{L}} + \frac{\left(34 - \frac{600}{L}\right)}{L}$ for L in m
- = $\frac{3.6}{\sqrt{L}} + \frac{\left(112 - \frac{6458}{L}\right)}{L}$ for L in ft
- K = 1.0 in general. For particular loading conditions and hull forms, determination of K according to the formula below may be necessary.
- = $13GM/B$, where $K \geq 1.0$ and GM = metacentric height, in m (ft)
- a_x, a_y, a_z = maximum dimensionless accelerations (i.e., relative to the acceleration of gravity) in the respective directions and they are considered as acting separately for calculation purposes, a_z does not include the component due to the static weight, a_y includes the component due to the static weight in the transverse direction due to rolling and a_x includes the component due to the static weight in the longitudinal direction due to pitching.

5.9.2 Internal Pressure for Initial Scantling Evaluation

To determine the inertial forces and added pressure heads for a completely filled cargo tank, the dominating vessel motion parameters induced by waves are to be calculated. The internal pressure p_{gc} resulting from the design vapor pressure p_o and the liquid pressure p_{gd} , but not including effects of liquid sloshing, as defined in 5C-8-4/13.2 and 5C-8-4/28.1 is to be calculated as follows:

$$p_{gc} = p_o + p_{gd} \quad \text{kgf/cm}^2$$

The internal liquid pressures are those created by the resulting acceleration of the center of gravity of the cargo due to the motions of the floating terminal. The value of internal liquid pressure p_{gd}

resulting from combined effects of gravity and dynamic accelerations is to be calculated as follows:

$$p_{gd} = \rho a_{\beta} Z_{\beta} 10^{-4} \text{ kgf/cm}^2$$

Note: For initial scantling evaluation, the cargo tank pressure is to be determined based on the full load condition corresponding to the scantling draft.

where

- ρ = specific weight of ballast or cargo, in kgf/m³-m
- a_{β} = dimensionless acceleration (i.e., relative to the acceleration of gravity), resulting from gravitational and dynamic loads, in an arbitrary direction β (see 3-3/5.9.3 FIGURE 8)
- Z_{β} = largest liquid height above the point where the pressure is to be determined, in m, measured from the tank shell in the β direction (see 3-3/5.9.3 FIGURE 9)

Tank domes considered to be part of the accepted total tank volume should be taken into account when determining Z_{β} unless the total volume of tank domes V_{dom} does not exceed the following value:

$$V_{dom} = V_{tank} \left(\frac{100 - FL}{FL} \right)$$

where

- V_{tank} = tank volume without any domes
- FL = filling limit according to Section 5C-8-15 of the *Marine Vessel Rules*

The direction which gives the maximum value (p_{gd})_{max} of p_{gd} is to be considered for the scantling requirements of plating and stiffeners of cargo tank boundaries. Where acceleration components in three directions need to be considered, an ellipsoid is to be used instead of the ellipse in 3-3/FIGURE 8. The above formula applies only to full tanks.

5.9.2(a) Simultaneous Internal Pressures.

When performing 3-D structural analysis such as required in TSA, it is to be performed for the IGC load cases: L.C. 3 IGC, L.C. 5 IGC and L.C. 7 IGC, see 3-3/5.9.3(a) TABLE 1B. The L.C. 3 IGC represents a condition of maximum internal pressure on the inner bottom, and L.C. 5 and 7 IGC represent a condition of maximum internal pressure on the starboard longitudinal bulkhead. The IGC pressure is to be treated as a simultaneous pressure loading wherein for each of the load cases the direction which gives the maximum IGC pressure on the inner bottom and on the longitudinal bulkhead are in turn treated as simultaneous pressures acting in the tank.

5.9.3 Simultaneous Internal Pressures for Strength Assessment

When performing 3D structural analysis such as required in TSA, it is to be performed for the IGC load cases as shown in 3-3/5.9.3(a) TABLE 1B to evaluate main supporting members in membrane tank floating terminals. The IGC pressure is to be treated as a simultaneous pressure loading wherein for each of the load cases the direction which gives the maximum IGC pressure on the inner bottom and then on the longitudinal bulkhead are each in turn treated as simultaneous pressures acting in the tank.

For finite element strength assessment, the internal pressure acting on cargo tanks corresponds to the instantaneous value when one dominant load parameter attains its maximum value. The internal pressure, p_i , positive toward outboard, for a completely filled tank, may be obtained from the following formula:

$$p_i = \rho[(k_{c\ell}a_x x_\ell + k_{ct}a_y y_\ell + k_{cv}a_z z_\ell) + z_\ell] + p_o \quad \text{N/cm}^2(\text{kgf/cm}^2, \text{lbf/in}^2)$$

where

$k_{c\ell}$ = load combination factor for longitudinal acceleration, as defined in 3-3/5.9.3(a) TABLE 1B

k_{ct} = load combination factor for transverse acceleration, as defined in 3-3/5.9.3(a) TABLE 1B

k_{cv} = load combination factor for vertical acceleration, as defined in 3-3/5.9.3(a) TABLE 1B

Origin = maximum pressure point of the tank from the center of the tank. This origin is also referred to as the zero dynamic pressure point.

x_ℓ = longitudinal distance from the reference point of the tank to the pressure point, in m (ft), positive toward bow for a fore cargo tank structure

y_ℓ = transverse distance from the reference point of the tank to the pressure point, in m (ft), positive toward starboard

z_ℓ = vertical distance from the reference point of the tank to the pressure point, in m (ft), positive downward

a_x, a_y and a_z are given in 3-3/5.9.1 and ρ is as specified in 3-3/5.9.1

FIGURE 4
Distribution of h_{Di}

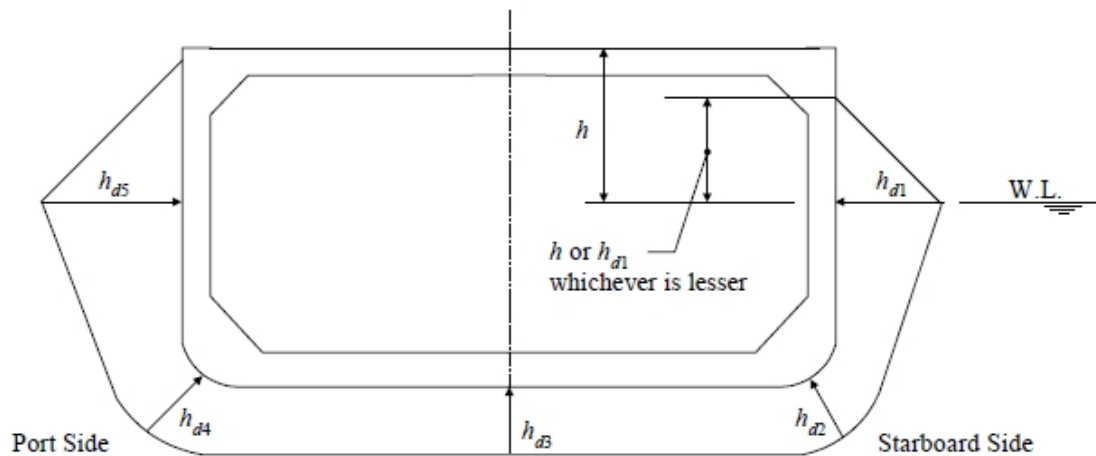

FIGURE 5
 Pressure Distribution Function k_{ℓ_0}

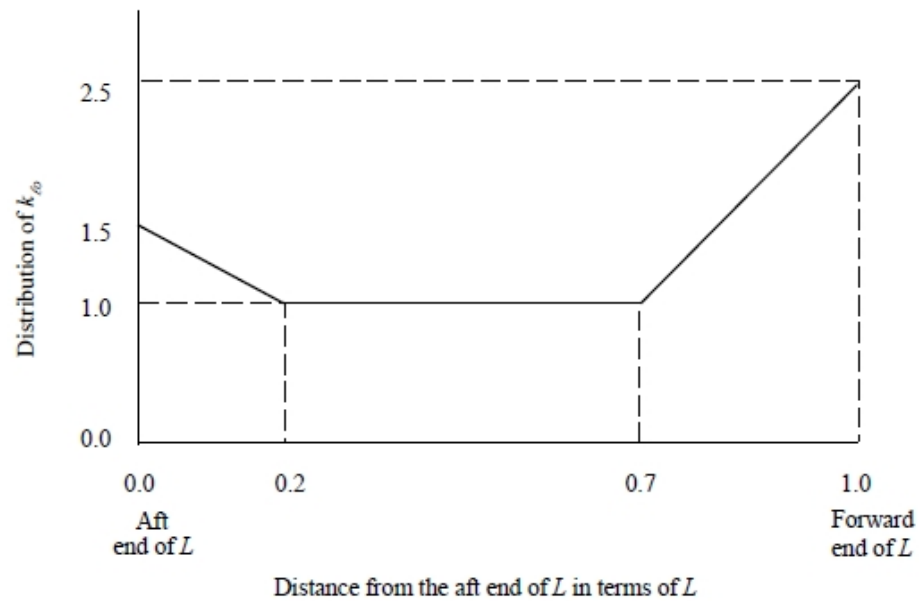

FIGURE 6
 Illustration of Determining Total External Pressure

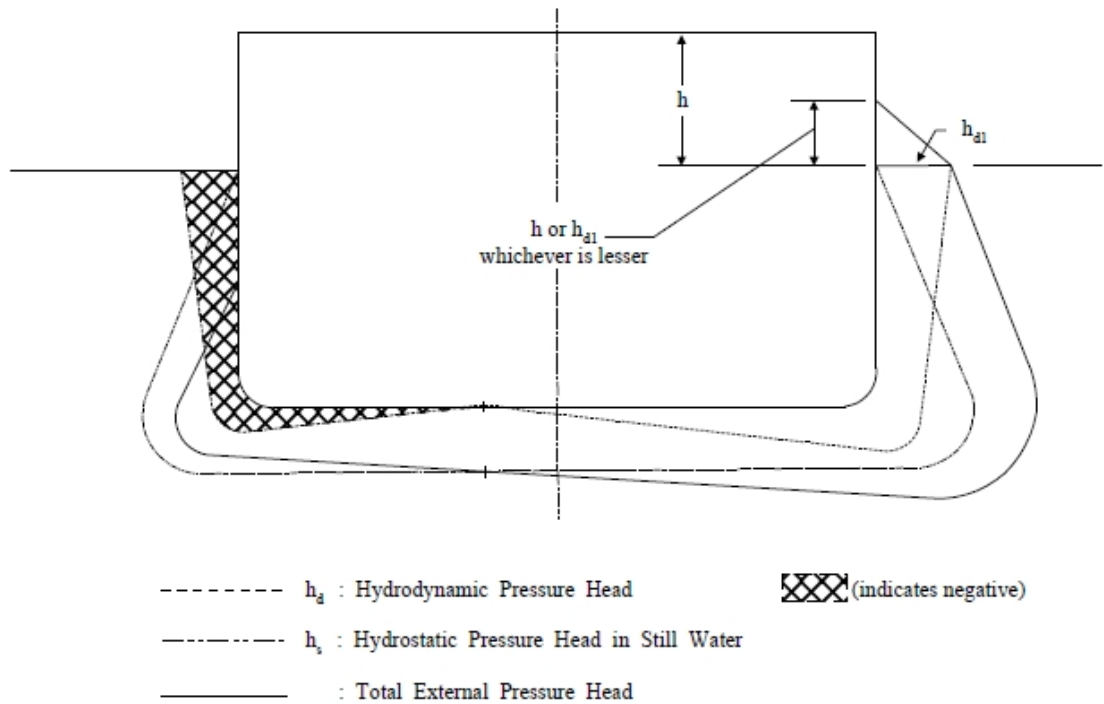

FIGURE 7A
Tank Shape Parameters

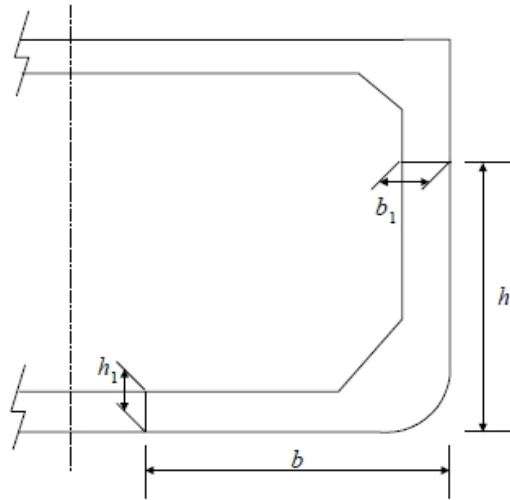

FIGURE 7B
Definition of Tank Geometry

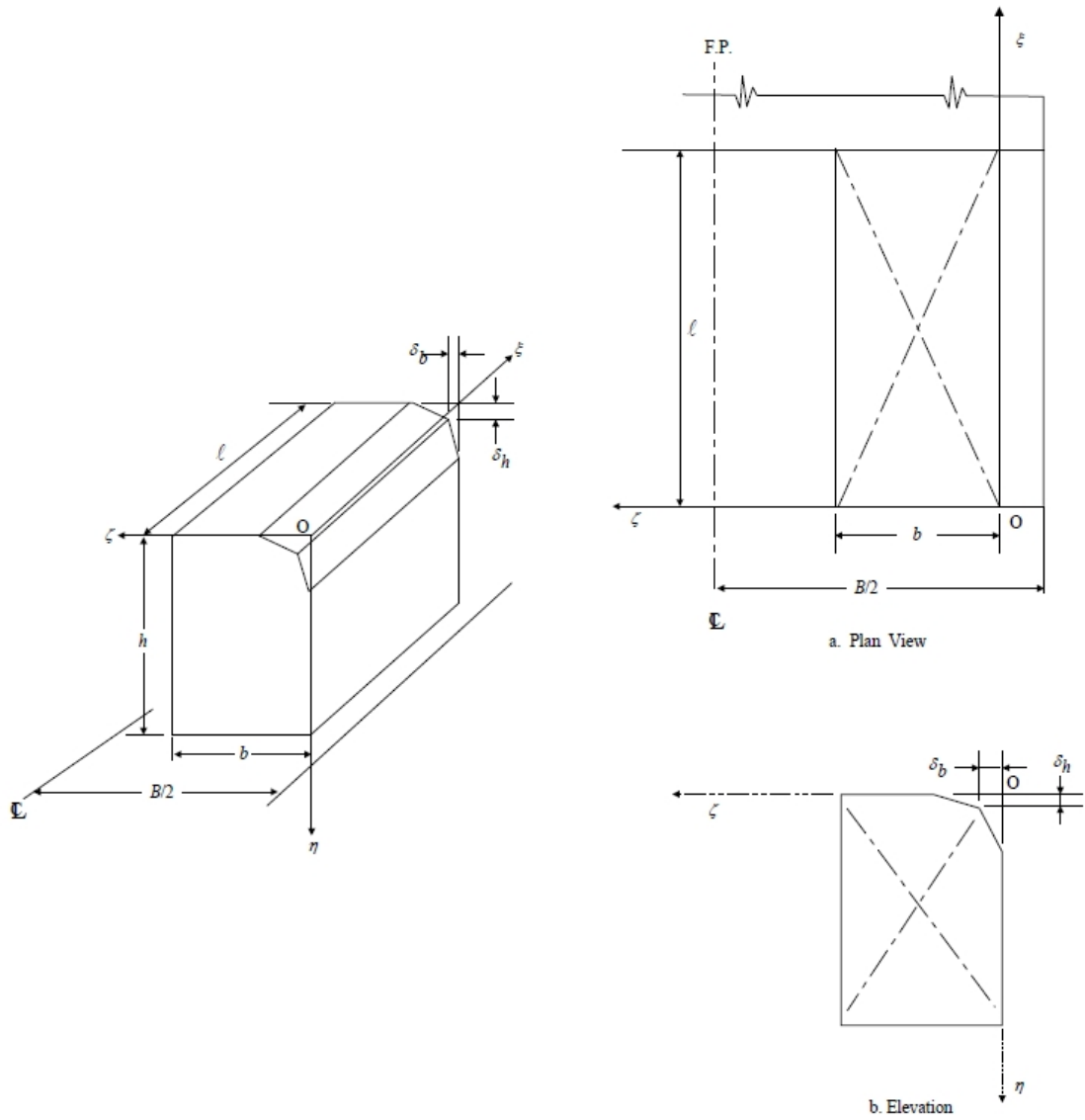
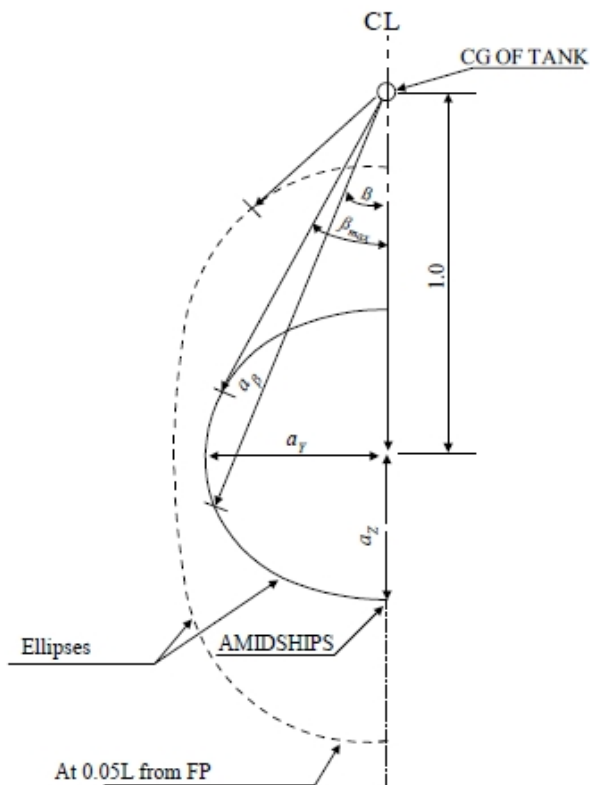
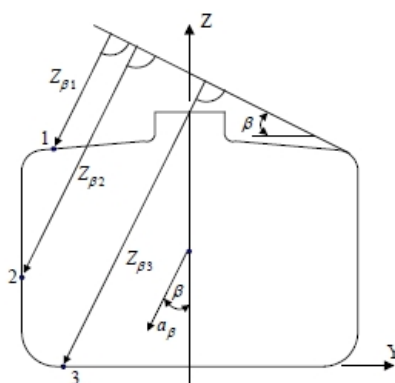

FIGURE 8
Acceleration Ellipse



a_{β} = resulting acceleration (static and dynamic) in arbitrary direction β
 a_y = transverse component of acceleration
 a_z = vertical component of acceleration

FIGURE 9
Determination of Internal Pressure Heads



Notes: Small tank domes not considered to be part of the accepted total volume of the cargo tank need not be considered when determining Z_{β} . See 3-3/5.9.2 for definition of small tank dome volume not to be considered in total tank volume.

FIGURE 10
Location of Tank for Nominal Pressure Calculation

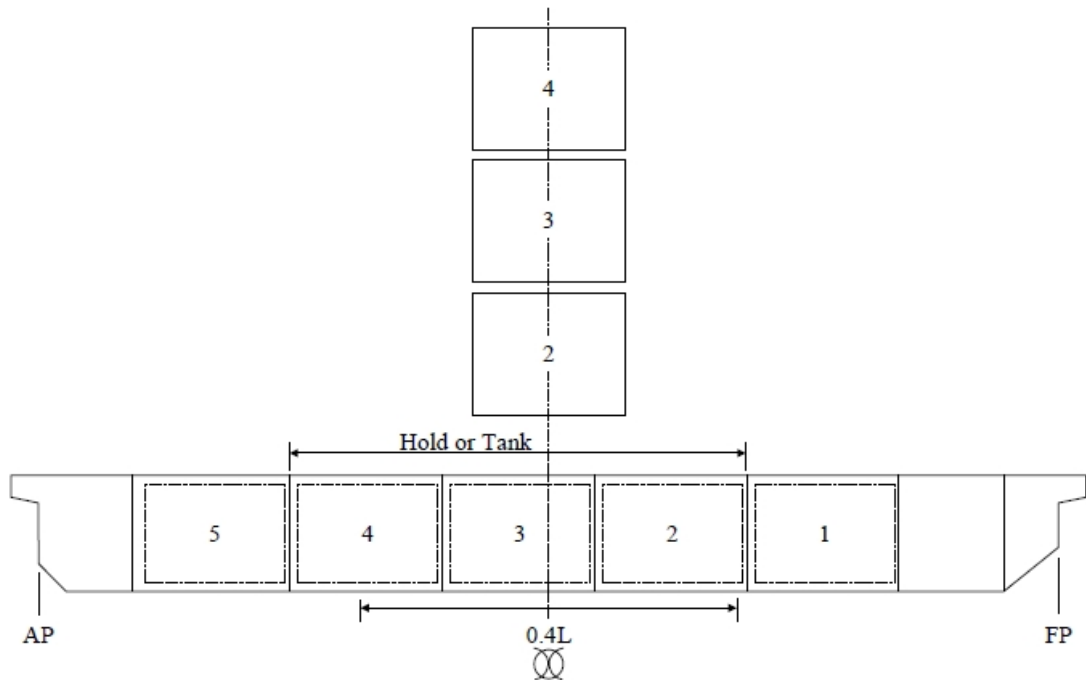

TABLE 1A
Combined Load Cases* for Total Strength Assessment (2018)

	<i>L.C. 1</i>	<i>L.C. 2</i>	<i>L.C. 3</i>	<i>L.C. 4</i>	<i>L.C. 5</i>	<i>L.C. 6</i>	<i>L.C. 7</i>	<i>L.C. 8</i>
A. Hull Girder Loads (See 3-3/5)**								
Vertical B.M.	Sag (-)	Hog (+)	Sag (-)	Hog (+)	Sag (-)	Hog (+)	Sag (-)	Hog (+)
k_c	1.0	1.0	0.7	0.7	0.3	0.3	0.4	0.4
Vertical S.F.	(+)	(-)	(+)	(-)	(+)	(-)	(+)	(-)
k_c	0.5	0.5	1.0	1.0	0.3	0.3	0.4	0.4
Horizontal B.M.					(-)	(+)	(-)	(+)
k_c	0.0	0.0	0.0	0.0	0.3	0.3	1.0	1.0
Horizontal S.F.					(+)	(-)	(+)	(-)
k_c	0.0	0.0	0.0	0.0	0.3	0.3	0.5	0.5
B. External Pressure (See 3-3/5.5)								
k_c	0.5	0.5	0.5	1.0	0.5	1.0	0.5	1.0
k_{f0}	-1.0	1.0	-1.0	1.0	-1.0	1.0	-1.0	1.0
C. Internal Tank Pressure (See 3-3/5.7)								
k_c	0.4	0.4	1.0	0.5	1.0	0.5	1.0	0.5
w_v	0.75	-0.75	0.75	-0.75	0.25	-0.25	0.4	-0.4

	<i>L.C. 1</i>	<i>L.C. 2</i>	<i>L.C. 3</i>	<i>L.C. 4</i>	<i>L.C. 5</i>	<i>L.C. 6</i>	<i>L.C. 7</i>	<i>L.C. 8</i>
w_{ℓ}	Fwd Bhd 0.25	Fwd Bhd -0.25	Fwd Bhd 0.25	Fwd Bhd -0.25	—	—	Fwd Bhd 0.2	Fwd Bhd -0.2
	Aft Bhd -0.25	Aft Bhd 0.25	Aft Bhd -0.25	Aft Bhd 0.25	—	—	Aft Bhd -0.2	Aft Bhd 0.2
w_t	—	—	—	—	Port Bhd -0.75	Port Bhd 0.75	Port Bhd -0.4	Port Bhd 0.4
	—	—	—	—	Stbd Bhd 0.75	Stbd Bhd -0.75	Stbd Bhd 0.4	Stbd Bhd -0.4
C_{ϕ} , Pitch	-0.35	0.35	-0.70	0.70	0.0	0.0	-0.30	0.30
C_{θ} , Roll	0.0	0.0	0.0	0.0	1.0	-1.0	0.30	-0.30
D. Reference Wave Heading and Motion of Vessel								
Heading Angle	0	0	0	0	90	90	60	60
Heave	Down	Up	Down	Up	Down	Up	Down	Up
Pitch	Bow Down	Bow Up	Bow Down	Bow Up	—	—	Bow Down	Bow Up
Roll	—	—	—	—	Stbd Down	Stbd Up	Stbd Down	Stbd Up

Notes:

- * $k_u = 1.0$ for all load components.
- ** Boundary forces should be applied to produce the above specified hull girder bending moment at the middle of the structural model and the specified hull girder shear force at one end of the middle hold of the model. The sign convention for the shear force corresponds to the forward end of the middle hold.

TABLE 1B
Additional IGC Load Cases* for Initial Scantling Evaluation of
Main Supporting Members in Membrane Tank FLGTs by FEA

	<i>L.C. 3 IGC</i>	<i>L.C. 5 IGC</i>	<i>L.C. 7 IGC</i>
A. Hull Girder Loads (See 3-3/5)**			
Vertical B.M.	Sag (-)	Sag (-)	Sag (-)
k_c	0.7	0.3	0.4
Vertical S.F.	(+)	(+)	(+)
k_c	1.0	0.3	0.4
Horizontal B.M.		(-)	(-)
k_c	0.0	0.3	1.0
Horizontal S.F.		(+)	(+)
k_c	0.0	0.3	0.5
B. External Pressure (See 3-3/5.5)			
k_c	0.5	0.5	0.5
k_{f0}	-1.0	-1.0	-1.0
C. Internal Tank Pressure for Cargo Tank (See 3-3/5.9)			

	<i>L.C. 3 IGC</i>	<i>L.C. 5 IGC</i>	<i>L.C. 7 IGC</i>
Vertical component of acceleration (k_{cv})	1.0	0.0	0.0
Longitudinal component of acceleration ($k_{c\ell}$)	0.0	0.0	0.5
Transverse component of acceleration (k_{ct})	0.0	1.0	0.867
D. Internal Tank Pressure for Ballast Tank (See 3-3/5.7)			
k_c	1.0	1.0	1.0
w_v	1.0	0.0	0.0
w_ℓ	—	—	Fwd Bhd 0.5
	—	—	Aft Bhd -0.5
w_t	—	Port Bhd -1.0	Port Bhd -0.867
	—	Stbd Bhd 1.0	Stbd Bhd 0.867
C_ϕ , Pitch	-1.0	0.0	-0.7
C_θ , Roll	0.0	1.0	0.7
E. Reference Wave Heading and Motion of Vessel			
Heading Angle	0	90	60
Heave	Down	Down	Down
Pitch	Bow Down	—	Bow Down
Roll	—	Stbd Down	Stbd Down

Notes:

* $k_u = 1.0$ for all load components.

** Boundary forces should be applied to produce the above specified hull girder bending moment at the middle of the structural model and the specified hull girder shear force at one end of the middle hold of the model. The sign convention for the shear force corresponds to the forward end of the middle hold.

Note L.C. 3 IGC, L.C. 5 IGC and L.C. 7 IGC follow the corresponding loading patterns in 3-3/ Figures 1A and 1B

L.C. 3 IGC: maximum internal pressure on inner bottom

L.C. 5 IGC: maximum internal pressure on Stbd Bhd

L.C. 7 IGC: maximum internal pressure on Stbd Bhd

TABLE 1C
Special Design Load Cases for Independent Cargo Tanks (1 September 2012)
(One side of Tank Loaded and Accidental Load Cases)

	<i>SLC1</i>	<i>SLC2</i>	<i>SLC3</i>	<i>SLC4</i>	<i>SLC5</i>
<i>Dominant Load Parameter</i>	One side of tank loaded condition	flooded condition (cofferdam bulkhead)	flooded condition (anti-float chocks)	collision condition	static heel angle
Draft (d_m)	$1/2d_f$	d_{flood} or $0.8D_f$	d_f	N/A	d_f

	<i>SLC1</i>	<i>SLC2</i>	<i>SLC3</i>	<i>SLC4</i>	<i>SLC5</i>
Friction Coefficient	N/A	N/A	0.10	0.10	0.10
Longitudinal Inertia Load	N/A	N/A	N/A	-0.25g	N/A
Vertical Inertia Load	1.00g	N/A	1.00g	1.00g	0.87g
Transverse Inertia Load	N/A	N/A	N/A	N/A	0.50g
Vertical Still Water BM	N/A	N/A	N/A	N/A	N/A

Notes:

- The frictional coefficient in 3-3/5.9.3(a) TABLE 1C for SLC3 and SLC5 is the representative value for the global finite element model. For the fine mesh finite element models representing individual supports or chocks, the frictional coefficient is to be taken as 0.3. Alternatively, the frictional coefficient may be determined from the measurement. The details of the support bearing materials, measurement procedure and measurement data are to be submitted for ABS review.
- For SLC1, account is to be taken of an increase of vapor pressure in port condition. This load case may be omitted, if the piping systems are designed to ensure that the cargoes on both sides of the centerline bulkhead can be loaded or discharged at the same rate.
- d_f scantling draft, in m
 d_{flood} deepest equilibrium waterline in the damaged conditions
 D_f imaginary freeboard depth, in m
- (1 September 2012) For SLC5 the static heel angle is defined as the most extreme angle of heel under damage conditions, but not to exceed 30°. If the static heel angle under damage conditions is not available during the initial design, the angle of submergence of the margin line at full load draft can be used, but not to exceed 30°.

TABLE 1D
Combined Load Cases for Repair Condition*

	<i>R.L.C. 1</i>	<i>R.L.C. 2</i>	<i>R.L.C. 3</i>	<i>R.L.C. 4</i>	<i>R.L.C. 5</i>	<i>R.L.C. 6</i>	<i>R.L.C. 7</i>	<i>R.L.C. 8</i>	<i>R.L.C. 9</i>	<i>R.L.C. 10</i>
A. Hull Girder Loads (See 3-3/5)**										
Vertical B.M.	Sag (-)	Hog (+)	Sag (-)	Hog (+)	Sag (-)	Hog (+)	Sag (-)	Hog (+)	Sag (-)	Hog (+)
k_c	1.00	1.00	0.50	0.50	0.25	0.25	0.80	0.80	0.60	0.60
Vertical S.F.	(+)	(-)	(+)	(-)	(+)	(-)	(+)	(-)	(+)	(-)
k_c	0.55	0.55	1.00	1.00	0.15	0.15	0.40	0.40	0.20	0.20
Horizontal B.M.					(-)	(+)	(-)	(+)	(-)	(+)
k_c	0.00	0.00	0.00	0.00	0.10	0.10	1.00	1.00	1.00	1.00
Horizontal S.F.					(+)	(-)	(+)	(-)	(+)	(-)
k_c	0.00	0.00	0.00	0.00	0.15	0.15	0.80	0.80	0.80	0.80
B. External Pressure (See 3-3/5.5)										
k_c	0.85	0.85	0.80	0.80	0.90	0.90	0.90	0.90	0.55	0.55
k_{f0}	-1.00	1.00	-1.00	1.00	-1.00	1.00	-1.00	1.00	-1.00	1.00

	<i>R.L.C. 1</i>	<i>R.L.C. 2</i>	<i>R.L.C. 3</i>	<i>R.L.C. 4</i>	<i>R.L.C. 5</i>	<i>R.L.C. 6</i>	<i>R.L.C. 7</i>	<i>R.L.C. 8</i>	<i>R.L.C. 9</i>	<i>R.L.C. 10</i>
C. Internal Tank Pressure (See 3-3/5.7)										
k_c	0.55	0.55	0.40	0.40	0.70	0.70	0.20	0.20	0.40	0.40
w_v	0.60	-0.60	0.35	-0.35	0.55	-0.55	0.15	-0.15	0.25	-0.25
w_ρ	Fwd Bhd 0.20	Fwd Bhd -0.20	Fwd Bhd 0.65	Fwd Bhd -0.65	—	—	Fwd Bhd 0.45	Fwd Bhd -0.45	Fwd Bhd 0.75	Fwd Bhd -0.75
	Aft Bhd -0.20	Aft Bhd 0.20	Aft Bhd -0.65	Aft Bhd 0.65	—	—	Aft Bhd -0.45	Aft Bhd 0.45	Aft Bhd -0.75	Aft Bhd 0.75
w_t	—	—	—	—	Port Bhd -0.95	Port Bhd 0.95	Port Bhd -0.05	Port Bhd 0.05	Port Bhd -0.10	Port Bhd 0.10
	—	—	—	—	Stbd Bhd 0.95	Stbd Bhd -0.95	Stbd Bhd 0.05	Stbd Bhd -0.05	Stbd Bhd 0.10	Stbd Bhd -0.10
c_ϕ , Pitch	-0.20	0.20	-0.45	0.45	-0.05	0.05	-0.10	0.10	-0.35	0.35
c_θ , Roll	0.00	0.00	0.00	0.00	1.00	-1.00	0.05	-0.05	0.05	-0.05
D. Reference Wave Heading and Motion of Installation										
Heading Angle	0	0	0	0	90	90	60	60	30	30
Heave	Down	Up	Down	Up	Down	Up	Down	Up	Down	Up
Pitch	Bow Down	Bow Up	Bow Down	Bow Up	Bow Down	Bow Up	Bow Down	Bow Up	Bow Down	Bow Up
Roll	—	—	—	—	Stbd Down	Stbd Up	Stbd Down	Stbd Up	Stbd Down	Stbd Up

* $k_u = 1.0$ for all load components.

** Boundary forces should be applied to produce the above specified hull girder bending moment at the middle of the structural model and the specified hull girder shear force at one end of the middle hold of the model. The sign convention for the shear force corresponds to the forward end of the middle hold.

TABLE 2
Load Cases for Sloshing

	<i>Hull Girder Loads*</i>				<i>External Pressures</i>			<i>Sloshing Pressures**</i>		<i>Reference Wave Heading and Motions</i>			
	<i>V.B.M.</i> [<i>H.B.</i> <i>M.</i>	<i>V.S.F.</i> <i>H.S.F.</i>	k_u k_u	k_c k_c]	k_u	k_c	k_{fo}	k_u	k_c	<i>Heading Angle</i>	<i>Heave</i>	<i>Pitch</i>	<i>Roll</i>
LC S - 1	(-) [(-)	(+) (+)	1.0 1.0	0.4 0.7]	1.0	0.5	-1.0	1.0	1.0	60°	Down	Bow Down	Stbd Down
LC S - 2	(+) [(+)	(-) (-)	1.0 1.0	0.4 0.7]	1.0	1.0	1.0	1.0	1.0	60°	Up	Bow Up	Stbd Up

- Notes:
- * For determining the total vertical bending moment for the above two load cases, 70% of the maximum designed still water bending moment may be used at the specified wave vertical bending moment station.
where:
V.B.M. is vertical wave bending moment
V.S.F. is vertical wave shear force
H.B.M. is horizontal wave bending moment
H.S.F. is horizontal wave shear force
 - ** The vertical distribution of the sloshing pressure head is shown in 3-3/Figures 12 and 13.

TABLE 3
Design Pressure for Local and Supporting Members (2018)

<i>A. Plating & Longitudinals/Stiffeners.</i>									
<i>The nominal pressure, $p = p_i - p_e$, is to be determined from load cases "a" & "b" below, whichever is greater, with $k_u = 1.10$ and $k_c = 1.0$ unless otherwise specified in the table</i>									
<i>Structural Members/ Components</i>		<i>Case "a" - At fwd end of the tank</i>				<i>Case "b" - At mid tank or fwd end of tank</i>			
		<i>Draft/ Wave Heading Angle</i>	<i>Location and Loading Pattern</i>	<i>Coefficients</i>		<i>Draft/ Wave Heading Angle</i>	<i>Location and Loading Pattern</i>	<i>Coefficients</i>	
				p_i	p_e			p_i	p_e
1.	Bottom Plating & Long'l	3/4 design draft/0°	Full ballast tank	A_i	A_e	Design draft/0°	Mid tank of empty ballast tanks	—	B_e
2.	Inner Bottom Plating & Long'l	3/4 design draft/0°	Full ballast tank, cargo tanks empty	A_i	—	Design draft/0°	Fwd end of full cargo tank, ballast tanks empty	A_i	—
3.	Side Shell Plating & Long'l	3/4 design draft/60°	Starboard side of full ballast tank	B_i	A_e	Design draft/60°	Mid tank of empty ballast tanks	—	B_e
4.	*Deck Plating & Long'l (Cargo Tank)	Design draft/0°	Full cargo tank	D_i	—				
5.	Deck Plating & Long'l (Ballast Tank)	3/4 design draft/0°	Full ballast tank	D_i	—				
6.	*Inner Skin Long'l Bhd. Plating & Long'l	3/4 design draft/60°	Starboard side of full cargo tank, ballast tank empty	B_i	—	3/4 design draft/60°	Fwd end and starboard side of full ballast tank, cargo tank empty	B_i	—
7.	Watertight Double Bottom Girder	3/4 design draft/60°	Starboard side of full double bottom tank or ballast tank, adjacent space empty	B_i	—				
8.	Watertight Side Stringer, second deck & Long'l Stool in centerline cofferdam bhd.	3/4 design draft/0°	Full upper tank, adjacent lower tank empty	A_i	—	3/4 design draft/ 0°	Fwd end of full lower tank, adjacent upper tank empty	D_i	—

A. Plating & Longitudinals/Stiffeners.									
<i>The nominal pressure, $p = p_i - p_e$, is to be determined from load cases “a” & “b” below, whichever is greater, with $k_u = 1.10$ and $k_c = 1.0$ unless otherwise specified in the table</i>									
Structural Members/ Components		Case “a” - At fwd end of the tank				Case “b” - At mid tank or fwd end of tank			
		Draft/ Wave Heading Angle	Location and Loading Pattern	Coefficients		Draft/ Wave Heading Angle	Location and Loading Pattern	Coefficients	
				p_i	p_e			p_i	p_e
9.	*Trans. Bhd. Plating & Stiffener for Membrane Tank FLGT (Cargo Tank)	Design draft/0°	Fwd. bhd. of full cargo tank	A_i	—				
10.	Trans. Bhd. Plating & Stiffener (Ballast Tank)	3/4 design draft/0°	Fwd. bhd. of full ballast tank, adjacent tanks empty	A_i	—				
11.	* Long'l Cofferdam Bhd. for Membrane Tank FLGT	3/4 design draft/60°	Starboard side of full cargo tank, adjacent tank empty	E_i	—	3/4 design draft/60°	Fwd end and center double bottom tank full, port cargo tank empty	B_i	—
12.	Centerline Cofferdam Bhd. & Trans. Bhd. for Independent Tank FLGT	—	—	—	—	d_{flood} or $0.8Df^{**}$	Flooded cargo** hold, double bottom & wing tanks empty (SLC 2)	—	—
13.	Long'l Lower Stool in centerline cofferdam bhd.	—	—	—	—	d_{flood} or $0.8Df^{***}$	Flooded double*** bottom and duct space	—	—
*	See note 4								
**	See Note 5								
***	See Note 6								

B. Main Supporting Members									
<i>The nominal pressure, $p = p_i - p_e$, is to be determined at the mid-span of the structural member at the starboard side of vessel from load cases “a” & “b” below, whichever is greater, with $k_u = 1.0$ and $k_c = 1.0$ unless otherwise specified in the table</i>									
Structural Members/ Components		Case “a” Mid-tank for Transverses				Case “b” Mid-tank for Transverses			
		Draft/ Wave Heading Angle	Location and Loading Pattern	Coefficients		Draft/ Wave Heading Angle	Location and Loading Pattern	Coefficients	
				p_i	p_e			p_i	p_e
14.	Double Bottom Floor & Girder	3/4 design draft/0°	Full cargo tank, ballast tanks empty	A_i	A_e	Design draft/0°	Cargo and ballast tanks empty	—	B_e
15.	Side Transverse	3/4 design draft/60°	Full cargo tank, ballast tanks empty	B_i	—	Design draft/60°	Cargo and ballast tanks empty	—	B_e
16.	Horizontal and Vertical Webs on Transverse Bulkhead	3/4 design draft/60°	Fwd bhd. of full cargo tank, adjacent tanks empty	B_i	—				

B. Main Supporting Members									
<i>The nominal pressure, $p = p_i - p_e$, is to be determined at the mid-span of the structural member at the starboard side of vessel from load cases “a” & “b” below, whichever is greater, with $k_u = 1.0$ and $k_c = 1.0$ unless otherwise specified in the table</i>									
Structural Members/ Components		Case “a” Mid-tank for Transverses				Case “b” Mid-tank for Transverses			
		Draft/ Wave Heading Angle	Location and Loading Pattern	Coefficients		Draft/ Wave Heading Angle	Location and Loading Pattern	Coefficients	
				p_i	p_e			p_i	p_e
17.	Deck Transverse:	3/4 design draft/60°	Cargo tank full, adjacent tanks empty	B_i	—				
18.	Deck girders	3/4 design draft/0°	Cargo tank full, adjacent tanks empty	A_i	—	3/4 design draft/60°	Cargo tank full, adjacent tanks empty	B_i	—

Notes:

- (2018) For calculating p_i and p_e , the necessary coefficients are to be determined based on the following designated groups:
 - For p_i
 $A_i: w_v = 0.75, w_\ell(\text{fwd bhd}) = 0.25, w_\ell(\text{aft bhd}) = -0.25, w_t = 0.0, c_\phi = -0.7, c_\theta = 0.0$
 $B_i: w_v = 0.4, w_\ell(\text{fwd bhd}) = 0.2, w_\ell(\text{aft bhd}) = -0.2, w_t(\text{starboard}) = 0.4, w_t(\text{port}) = -0.4, c_\phi = -0.7, c_\theta = 0.7$
 $D_i: w_v = -0.75, w_\ell(\text{fwd bhd}) = 0.25, w_t = 0.0, c_\phi = -0.7, c_\theta = 0.0$
 $E_i: w_v = 0.4, w_\ell(\text{fwd bhd}) = 0.2, w_t(\text{center cofferdam bhd}) = 0.4, c_\phi = -0.7, c_\theta = -0.7$
 - For p_e
 $A_e: k_{\ell 0} = 1.0, k_u = 1.0, k_c = -0.5$
 $B_e: k_{\ell 0} = 1.0$
- For structures within 0.4L amidships, the nominal pressure is to be calculated for a tank located amidships. Each cargo tank or ballast tank in the region should be considered as located amidships as shown in 3-3/5.9.3 FIGURE 10.
- In calculation of the nominal pressure, ρg the specific weight of the fluid cargoes and the ballast water is not to be taken less than 0.49 N/cm²-m (0.05 kgf/cm²-m, 0.2168 lbf/in²-ft) and 1.005 N/cm²-m (0.1025 kgf/cm²-m, 0.4444 lbf/in²-ft), respectively.
- For structural members 4, 6, 9 and 11, sloshing pressures are to be considered in accordance with 3-3/11.3. For calculation of sloshing pressures refer to 3-3/11.5 with ρg not less than 0.49 N/cm²-m (0.05 kgf/cm²-m, 0.2168 lbf/in²-ft).
- The nominal pressure for watertight requirement for flooding condition may be taken as the cargo hold filled up to the deepest equilibrium waterline in the damaged conditions d_{flood} . This is not to be less than the cargo hold filled up to 0.8 of freeboard deck at center D_f . If d_{flood} is not available, $0.8D_f$ should be used as an equilibrium waterline for this case.
- (1 September 2012) The nominal pressure for watertight requirement for flooding condition may be taken as the ballast tanks and duct space are damaged and filled up to the deepest equilibrium waterline in the damaged conditions d_{flood} . This is not to be less than the cargo hold filled up to 0.8 of freeboard deck at center D_f . If d_{flood} is not available, $0.8D_f$ should be used as an equilibrium waterline for this case.

7 Nominal Design Loads

7.1 General

The nominal design loads specified below are to be used for determining the required scantlings of hull structures in conjunction with the specified permissible stresses given in Chapter 3, Section 4.

7.3 Hull Girder Loads - Longitudinal Bending Moments and Shear Forces

7.3.1 Total Vertical Bending Moment and Shear Force

The total longitudinal vertical bending moments and shear forces may be obtained from the following equations:

$$M_t = M_{sw} + k_u k_c M_w \quad \text{kN-m (tf-m, Ltf-ft)}$$

$$F_t = F_{sw} + k_u k_c F_w \quad \text{kN (tf, Ltf)}$$

where

M_{sw} and M_w are the still-water bending moment and wave-induced bending moment respectively, as specified in 3-3/3.1 and 3-3/5.1.1 for either hogging or sagging conditions.

F_{sw} and F_w are the still-water and wave-induced shear forces respectively, as specified in 3-3/3.1 and 3-3/5.1.3 for either positive or negative shears.

k_u is a load factor and may be taken as 1.0 unless otherwise specified.

k_c is a correlation factor and may be taken as 1.0 unless otherwise specified.

For determining the hull girder section modulus for 0.4L amidships as specified in 3-4/3, the maximum still-water bending moments, either hogging or sagging, are to be added to the hogging or sagging wave bending moments, respectively. Elsewhere, the total bending moment may be directly obtained based on the envelope curves as specified in 3-3/3.1 and 3-3/5.1.

For this purpose, $k_u = 1.0$, and $k_c = 1.0$

7.3.2 Horizontal Wave Bending Moment and Shear Force

For non-head sea conditions, the horizontal wave bending moment and the horizontal shear force as specified in 3-3/5.3 are to be considered as additional hull girder loads, especially for the design of the side shell and inner skin structures. The effective horizontal bending moment and shear force, M_{HE} and F_{HE} , may be determined by the following equations:

$$M_{HE} = k_u k_c M_H \quad \text{kN-m (tf-m, Ltf-ft)}$$

$$F_{HE} = k_u k_c F_H \quad \text{kN (tf, Ltf)}$$

where k_u and k_c are a load factor and a correlation factor, respectively, which may be taken as unity unless otherwise specified.

7.5 Local Loads for Design of Main Supporting Structures

In determining the required scantlings of the main supporting structures, such as girders, transverses, stringers, floors and deep webs, the nominal loads induced by the liquid pressures distributed over both sides of the structural panel within the tank boundaries should be considered for the worst possible load combinations. In general, considerations should be given to the following two loading cases accounting for the worst effects of the dynamic load components.

- i) Maximum internal pressures for a fully filled tank with the adjacent tanks empty and minimum external pressures, where applicable.
- ii) Empty tank with the surrounding tanks full and maximum external pressures, where applicable.

Taking the side shell supporting structure as an example, the nominal loads can be determined from either:

- i) $p_i = k_s \rho g (\eta + k_u h_d) \max.$ and

$$p_e = \rho g(h_s + \beta_{EPS/EPP} k_u h_{de}) \quad \text{min.}$$

ii) $p_i = 0$ and

$$p_e = \rho g(h_s + \beta_{EPS/EPP} k_u h_{de}) \quad \text{max.}$$

where

$$k_u = 1.0$$

$$\beta_{EPS/EPP} = \text{ESF for external pressure starboard/port, as defined in Chapter 3, Appendix 3}$$

$\rho g, \eta, h_d, h_s, h_{de}, k_s$ are as defined in 3-3/5.5 and 3-3/5.7.

Specific information required for calculating the nominal loads are given in 3-3/5.9.3 TABLE 3 for various structural members and configurations.

7.7 Local Pressures for Design of Plating and Longitudinals

In calculating the required scantlings of plating, longitudinals and stiffeners, the nominal pressures should be considered for the two load cases given in 3-3/7.5, using $k_u = 1.1$ for p_i and p_e instead of $k_u = 1.0$ as shown above. The necessary details for calculating p_i and p_e are given in 3-3/5.9.3 TABLE 3.

9 Combined Load Cases

9.1 Combined Load Cases for Structural Analysis

For assessing the strength of the hull girder structure and in performing a structural analysis as outlined in Chapter 3, Section 5, the combined load cases specified in 3-3/Tables 1A and 1B for the hull structure are to be considered. For independent cargo tanks, special load cases specified in 3-3/5.9.3(a) TABLE 1C are also to be considered. Additional combined load cases may be required as warranted. The loading patterns are shown in 3-3/Figures 1A, 1B and 1C for three cargo tank lengths. The necessary correlation factors and relevant coefficients for the loaded tanks are also given in 3-3/Tables 1A, 1B and 1C. The total external pressure distribution including static and hydrodynamic pressure is illustrated in 3-3/5.9.3 FIGURE 6.

9.3 Combined Load Cases for Failure Assessment

For assessing the failure modes with respect to material yielding, buckling and ultimate strength, the following combined load cases are to be considered.

9.3.1 Yielding, Buckling and Ultimate Strength of Local Structures

For assessing the yielding, buckling and ultimate strength of local structures, the combined load cases as given in 3-3/Tables 1A, 1B and 1C are to be considered.

9.3.2 Fatigue Strength

For assessing the fatigue strength of structural joints, the combined load cases FLC1 - FLC8 given in Chapter 3, Appendix 1, "Guide for Fatigue Assessment", are to be used for a first level fatigue strength assessment.

11 Sloshing Loads in Membrane Tanks

11.1 General

Except for tanks that are situated wholly within the double side or double bottom, the natural periods of liquid motions and sloshing loads are to be examined in assessing the strength of boundary structures for all cargo tanks which will be partially filled between $0.5h_d$ (or $0.1h$, if lesser) and $0.9h$ (h_d and h are as defined in 3-3/11.5.3 FIGURE 11). The sloshing pressure heads given in this Subsection may be used for determining the strength requirements for the tank structures. Alternatively, sloshing loads may be

determined by model experiments. Methodology and procedures of tests and measurements are to be fully documented and referenced. They are to be submitted for review by the appropriate ABS Technical Office.

11.3 Strength Assessment of Tank Boundary Structures

For each of the anticipated loading conditions, the "critical" filling levels of the tank should be avoided so that the natural periods of fluid motions in the longitudinal and transverse directions will not synchronize with the natural periods of the vessel's pitch and roll motions, respectively. It is further recommended that the natural periods of the fluid motions in the tank, for each of the anticipated filling levels, are at least 20% greater or smaller than that of the relevant vessel's motion. If the "critical" filling levels of the tank can not be avoided, tank boundary structures are to be designed in accordance with 3-4/13 to withstand the sloshing pressures specified in 3-3/11.5. The natural period of the fluid motion may be approximated by the following equations:

$$T_x = (\ell)^{1/2}/k \text{ seconds} \quad \text{in the longitudinal direction}$$

$$T_y = (b_f)^{1/2}/k \text{ seconds} \quad \text{in the transverse direction}$$

where

$$\ell = \text{length of the tank, as defined in 3-3/11.5.3 FIGURE 11, in m (ft)}$$

$$b_f = \text{breadth of the liquid surface at } d_o, \text{ as defined in 3-3/11.5.3 FIGURE 11, in m (ft)}$$

$$k = [(\tanh H_1)/(4\pi/g)]^{1/2}$$

$$H_1 = \pi d_o/\ell \text{ or } \pi d_o/b_f$$

$$d_o = \text{filling depth, as defined in 3-3/11.5.3 FIGURE 11, in m (ft)}$$

$$g = \text{acceleration of gravity} = 9.8 \text{ m/sec}^2 \text{ (32.2 ft/sec}^2\text{)}$$

The natural periods given in 3-3/5.7 for pitch and roll of the vessel, T_p and T_r , using the actual GM value, if available, may be used for this purpose.

11.5 Sloshing Pressures

11.5.1 Nominal Sloshing Pressure

For cargo tanks with filling levels within the critical range specified in 3-3/11.3, the internal pressures p_{is} , induced by static head and sloshing pressures, positive toward tank boundaries, may be expressed in terms of equivalent liquid pressure head, h_e , as given below (See 3-3/11.5.3 FIGURE 12):

$$p_{is} = \rho g h_e \geq 0 \quad \text{N/cm}^2 \text{ (kgf/cm}^2, \text{ lbf/in}^2\text{)}$$

where

$$h_e = \begin{cases} C_m (d_m - y) + k_u h_c & \text{for } y \text{ below filling level } d_m \\ C_m (d_m - y) & \text{need not exceed } h, \text{ and } h_e \text{ need not exceed } h_e \text{ calculated at } y = 0.15h \text{ for } y \\ & \text{below } 0.15h, \text{ as shown in 3-3/11.5.3 FIGURE 12} \end{cases}$$

$$= k_u [h_c + (h_{tu} - h_c)(y - d_m)/(h - h_u - d_m)] \quad \text{for } y \text{ above } d_m \text{ and below } (h - h_u)$$

$$= k_u [h_{tu} + (h_t - h_{tu})(y - h + h_u)/h_u] \quad \text{for } y \text{ above } (h - h_u) \text{ and below } h$$

$$C_m = \text{coefficient in accordance with 3-3/11.5.3 FIGURE 15}$$

$$d_m = \text{filling level for maximum } h_c \text{ calculated with } C_{\phi s} \text{ and } C_{\theta s} \text{ equal to 1.0, in m (ft), as shown in 3-3/11.5.3 FIGURE 12, not to be taken less than } 0.55h$$

- k_u = load factor, and may be taken as 1.0 unless otherwise specified
- h_c = maximum average sloshing pressure heads, in m (ft), to be obtained from calculations as specified below for at least two filling levels, $0.55h$ and the one closest to the resonant period of vessel's motions, between $0.2h$ and $0.9h$. h_c may be taken as constant over the tank depth, h . (See 3-3/11.5.3 FIGURE 12)
- h_t = sloshing pressure heads for upper bulkhead, in m (ft), to be obtained from calculation below
- h_{tu} = sloshing pressure heads at the lower corner of the upper sloping bulkhead, in m (ft), to be obtained from calculation below
- h = depth of tank, as defined in 3-3/11.5.3 FIGURE 11, in m (ft)
- y = distance, in m (ft), measured from the tank bottom to the point being considered

ρg is as defined in 3-3/5.7.2.

h_e on the tank top is given as:

- $h_e = h_t$ within the longitudinal extent of 0.2ℓ from the transverse bulkhead or within the transverse extent of $0.2b_t$ from the upper corner of the upper sloping bulkhead as shown in 3-3/11.5.3 FIGURE 14. The value of h_t is taken from the nearest bulkhead.
- = 0 for distances greater than 0.3ℓ from the transverse bulkhead and $0.3b_t$ from the upper corner of the upper sloping bulkhead

h_e is linearly interpolated in the other area. b_t is breadth of the tank top.

The values of h_c and h_t may be obtained from the following equations:

$$h_c = k_c (C_{\phi_s} h_\ell^2 + C_{\theta_s} h_b^2)^{1/2} \text{ m (ft)}$$

$$h_t = k_c \delta_t (C_{\phi_s} + h_{t\ell}^2 + C_{\theta_s} h_{tb}^2)^{1/2} \text{ m (ft)}$$

$$h_{tu} = k_c \delta_{tu} (C_{\phi_s} + h_{tu\ell}^2 + C_{\theta_s} h_{tub}^2)^{1/2} \text{ m (ft)}$$

where

- k_c = correlation factor for combined load cases, and may be taken as 1.0 unless otherwise specified
- $\delta_t = 0.5$
- $\delta_{tu} = 0.5$ for $\gamma_u < 96$ degrees
- = 1.0 otherwise
- $h_\ell = \phi_{es} \ell C_{t\ell} [0.018 + C_{f\ell} (1.0 - d_o/h)/\phi_{es}] d_o/h \text{ m (ft)}$
- $h_b = \theta_{es} b C_{tb} [0.016 + C_{fb} (1.0 - d_o/h)/\theta_{es}] d_o/h \text{ m (ft)}$
- $h_t = 0.0068\ell (\phi_{es} + 40) (\phi_{es})^{1/2} \text{ m (ft)}$
- ℓ
- $h_{tb} = 0.0055b C'_{tb} (\theta_{es} + 35) (\theta_{es})^{1/2} \cos^2 \gamma_u \text{ m (ft)}$

$$h_{tu} = h_{t\ell} + h_u (h_{t\ell} - h_{t\ell}) / (h - d_m) \text{ m (ft)}$$

$$h_{ub} = 0.007b C''_{tb} (\theta_{es} + 35) (\theta_{es})^{1/2} \sin^2 \gamma_u \text{ m (ft)}$$

C_{ϕ_s} and C_{θ_s} are the weighted coefficients as given in 3-3/11.5.3 FIGURE 15.

$$\phi_{es} = 0.71\phi$$

$$\theta_{es} = 0.71\theta$$

ϕ and θ are as defined in 3-3/5.7.1.

$$C_f = 0.792[d_o/(\ell)]^{1/2} + 1.98$$

$$C_{fb} = 0.704[d_o/(b)]^{1/2} + 1.76$$

$$C_t = 0.9 x_o / [1 + 9(1 - x_o)^2] \geq 0.25$$

b = breadth of the tank in m (ft), as defined in 3-3/11.5.3 FIGURE 11

$$x_o = T_x / T_p$$

$$x_o = x_o \quad \text{if } x_o \leq 1.0$$

$$x_o = 1/x_o \quad \text{if } x_o > 1.0$$

$$C_{tb} = 0.9 y_o / [1 + 9(1 - y_o)^2] \geq 0.25$$

$y_o = T_y / T_r$ If roll radius of gyration is not known, $0.39B$ may be used in the calculation of T_r

$$y_o = y_o \quad \text{if } y_o \leq 1.0$$

$$y_o = 1/y_o \quad \text{if } y_o > 1.0$$

ℓ , d_o , T_x and T_y are as defined in 3-3/11.3.

T_p and T_r are as defined in 3-3/5.7.

$C'_{t\ell}$ and C'_{tb} are $C_{t\ell}$ and C_{tb} for $d_o = 0.70h$; d_o is as defined in 3-3/11.3.

C''_{tb} is C_{tb} for $d_o = 0.70(h - h_u)$.

$h'_{t\ell}$ is $h_{t\ell}$ for the maximum h_c .

$h_{t\ell}$ shall not be less than h_p ; h_{tb} shall not be less than h_r .

$$h_p = \ell \sin(\phi_{es})$$

$$h_r = b_{t\ell} \sin(\theta_{es})$$

$b_{t\ell}$ is as defined in 3-3/11.3.

11.5.2 Additional Nominal Sloshing Pressure for Low-Filling Resonance

When the natural periods at the filling level higher than $1.13h_d$ or $0.17h$, whichever is less, and at filling level lower than 0.2ℓ or $0.2b$, whichever is higher, are at least 20% greater or smaller than that of the relevant vessel's motion, the nominal sloshing pressure for low-filling resonance, p_i , should be used for the lower filling level in lieu of the nominal pressure given in 3-3/11.5.1 (See 3-3/11.5.3 FIGURE 13) unless the vessel loading manual indicates that the filling level higher than $1.13h_d$ or $0.17h$, whichever is less, and lower than 0.2ℓ or $0.2b$, whichever is higher, are avoided.

$$p_i = \rho gh_i \quad \text{N/cm}^2 \text{ (kgf/cm}^2, \text{ lbf/in}^2\text{)}$$

but not less than p_{is} given in 3-3/11.5.1 at the same location

where

$$\begin{aligned} h_{i\ell} &= k_c (C_{\phi_i} h_{i\ell}^2 + C_{\theta_i} h_{ib}^2)^{1/2} \text{ m (ft)} \\ h_{i\ell} &= 0.067\ell\phi_{es} \quad \text{for } y \text{ below } d_\ell \\ &= 0 \quad \text{for } y \text{ above } d_\ell + 1 \text{ m} \\ h_{ib} &= 0.067b\theta_{es} \quad \text{for } y \text{ below } d_\ell \\ &= 0 \quad \text{for } y \text{ above } d_\ell + 1 \text{ m} \end{aligned}$$

$h_{i\ell}$ and h_{ib} vary linearly in $d_\ell < y < d_\ell + 1 \text{ m}$.

$C_{i\ell}$ and C_{ibi} are $C_{i\ell}$ and C_{ib} at $d_o = d_\ell$, respectively.

d_ℓ , C_{ϕ_i} and C_{θ_i} are defined in 3-3/11.5.3 TABLE 4.

b is the breadth of the tank, in m (ft), as defined in 3-3/11.5.3 FIGURE 11.

ℓ and d_o are as defined in 3-3/11.3.

All other parameters are as defined in 3-3/11.5.1.

11.5.3 Sloshing Loads for Assessing Strength of Structures at Tank Boundaries

11.5.3(a)

In assessing the strength of tank boundary supporting structures, the two combined load cases with loading pattern shown in 3-3/11.5.3(c), with the specified sloshing loading conditions shown in 3-3/5.9.3 TABLE 2, are to be considered at least for two filling levels, $= 0.7$ and the one where is maximized when performing a 3D structural analysis. When the tank is in the low-filling resonance condition as defined in 3-3/11.5.2, an additional filling level, ℓ should be considered. The sloshing pressure, and the average sloshing pressure head, may be obtained in accordance with 3-3/11.5.1 using each filling level under consideration, in lieu of .

11.5.3(b)

In assessing the strength of plating and stiffeners at tank boundaries, local bending of the plating and stiffeners with respect to the local sloshing pressures for structural members/elements is to be considered, in addition to the nominal loadings specified for the 3D analysis in 3-3/11.5.3(a) above. In this regard, should be taken as 1.15 instead of 1.0, shown in 3-3/11.5.3(a) above for the combined load cases, to account for the maximum pressures due to possible non-uniform distribution.

TABLE 4
Definition of d_ℓ , $C_{\phi i}$ and $C_{\theta i}$

	$0.8 \leq T_x/T_p \leq 1.2$ and $0.8 \leq T_y/T_r \leq 1.2$	$0.8 \leq T_x/T_p \leq 1.2$ and $0.8 > T_y/T_r$ or $T_y/T_r > 1.2$	$0.8 > T_x/T_p$ or $T_x/T_p > 1.2$ and $0.8 \leq T_y/T_r \leq 1.2$
d_ℓ	0.2 ℓ or 0.2 b , whichever is greater	0.2 ℓ	0.2 b
$C_{\phi i}$	$C_{\phi s}$	$C_{\phi s}$	0
$C_{\theta i}$	$C_{\theta s}$	0	$C_{\theta s}$

where

T_x , T_y and ℓ are as defined in 3-3/11.3.

b is the breadth of the tank in m (ft), as defined in 3-3/11.5.3 FIGURE 11.

T_p and T_r are as defined in 3-3/5.7.

FIGURE 11
Definition of Tank Geometry

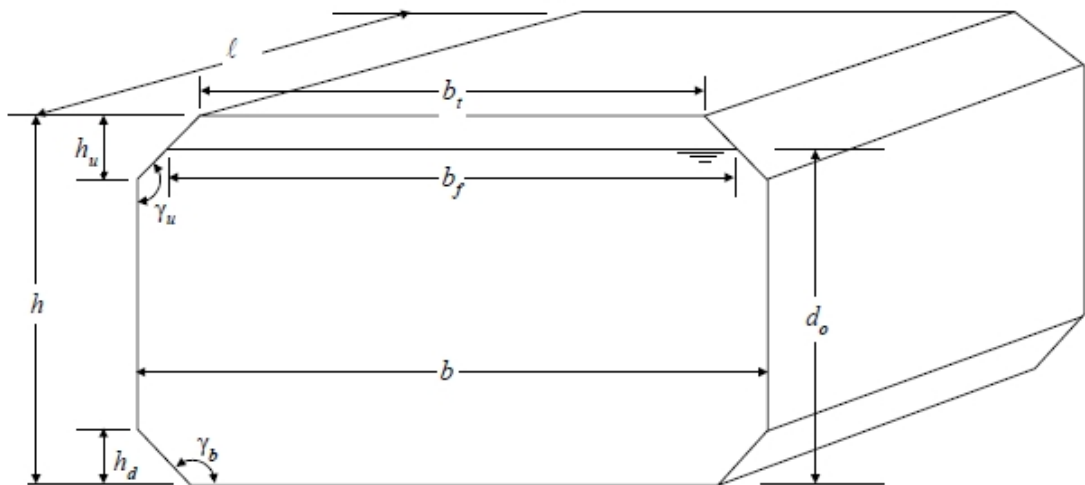

FIGURE 12
 Vertical Distribution of Nominal Slosh Pressure Head, h_e

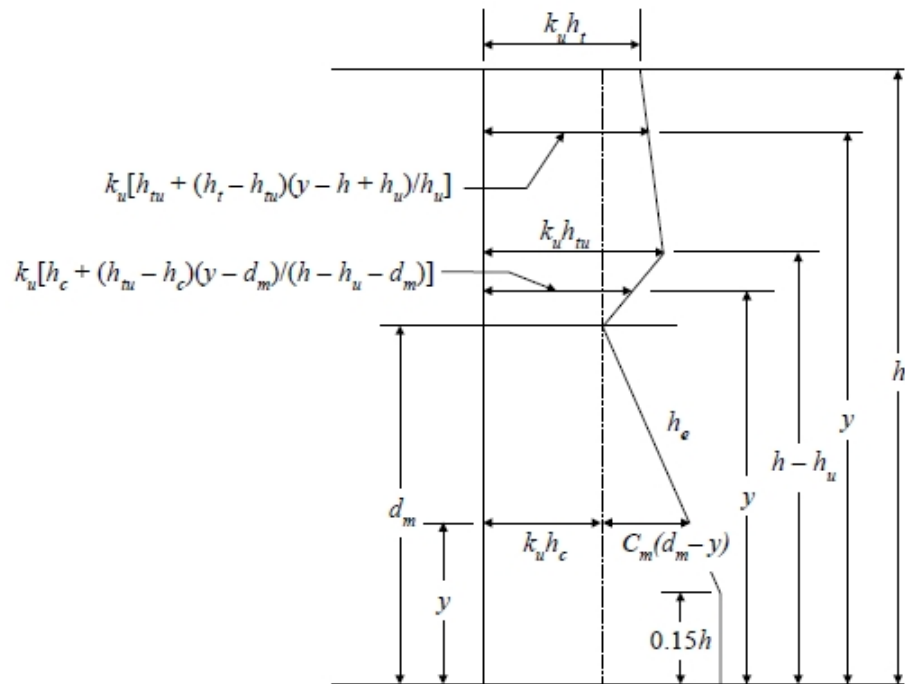

FIGURE 13
 Vertical Distribution of Nominal Slosh Pressure Head, h_i for Low-Filling Resonance

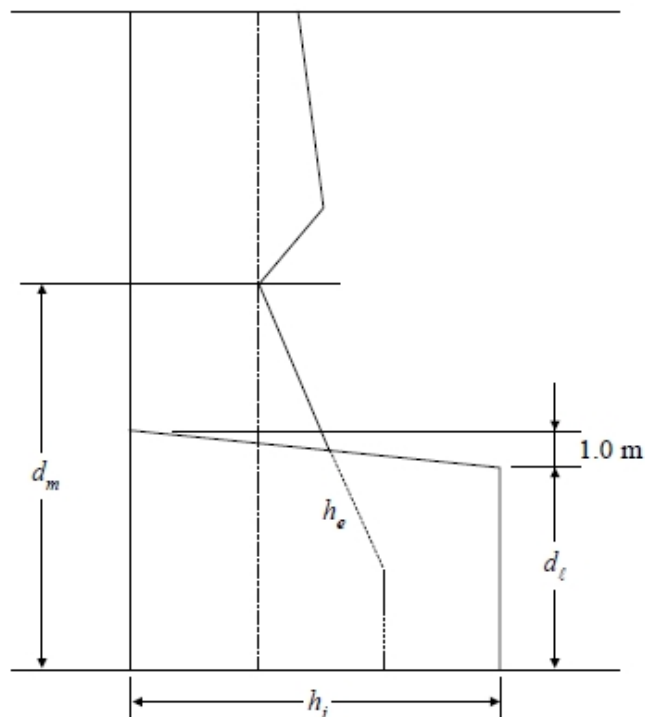
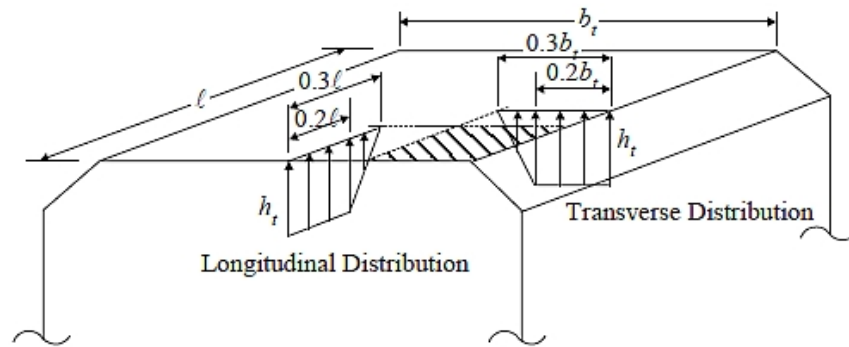

FIGURE 14
Distribution of Nominal Slosh Pressure Head, h_t on Tank Top



Note: At the corner area of the tank top where the longitudinal and transverse extents overlap (hatched portion ) , h_o is to be taken the greater value of h_t in either direction.

FIGURE 15
 Horizontal Distribution of Simultaneous Slosh Pressure Heads, $h_c (\phi_s \theta_s)$
 or $h_t (\phi_s \theta_s)$



Note: h_c may be taken as zero for the deck and inner bottom

FIGURE 16A
 Loading Patterns for Sloshing Loads Cases

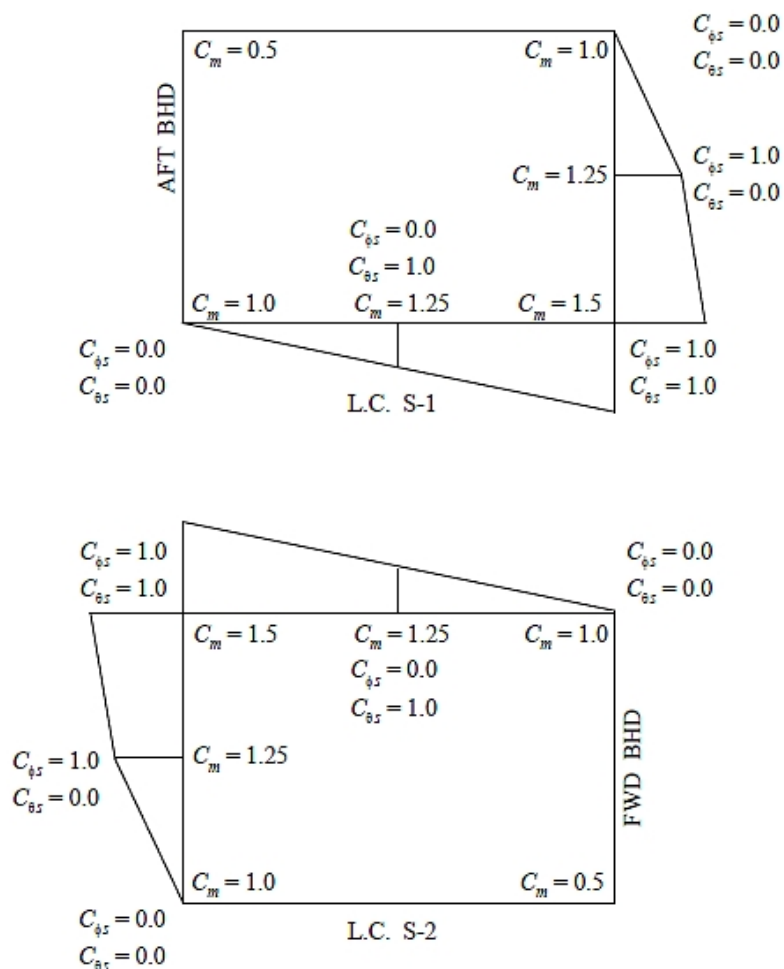
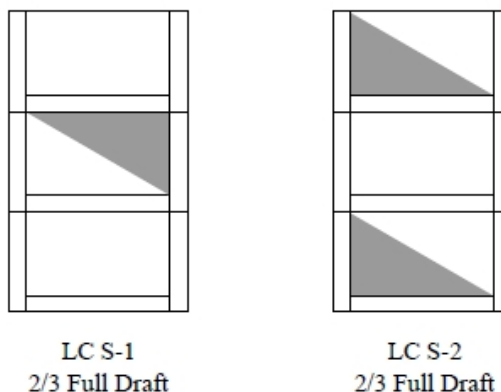
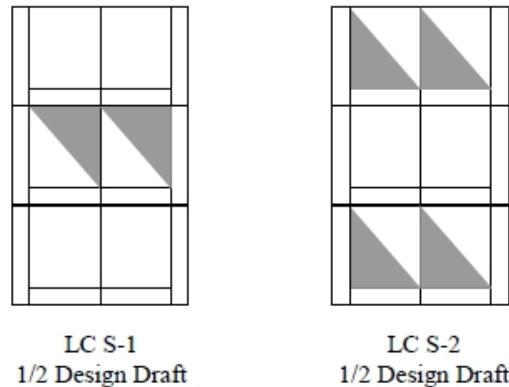

FIGURE 16B
Loading Patterns for Sloshing Loads Cases



13 Sloshing Loads for Prismatic Independent Tanks

13.1 General

13.1.1

Except for tanks that are situated wholly within the double side or double bottom, the natural periods of liquid motions and sloshing loads are to be examined in assessing the strength of boundary structures for all cargo or ballast tanks which will be partially filled between 20% and 90% of tank capacity. The sloshing pressure heads given in this Subsection may be used for determining the strength requirements for the tank structures. Alternatively, sloshing loads may be calculated either by model experiments or numerical simulation using three-dimensional flow analysis for unrestricted service conditions and for sea conditions of the specific site of operation. Methodology and procedures of tests and measurements or analysis methods are to be fully documented and submitted for review.

13.1.2

The effects of impulsive sloshing pressures on the design of the main supporting structures of tank transverse and longitudinal bulkheads are subject to special consideration.

13.3 Strength Assessment of Tank Boundary Structures

13.3.1 Tank Length and Pitch Induced Sloshing Loads

Tanks of length 54 m (177 ft) or greater are to satisfy requirements of either of the preventative measures given in 3-3/13.3.3 or 3-3/13.3.4. Where the tank has smooth surfaces, one or more swash bulkheads are to be fitted. Structural reinforcement is to be provided to the tank ends, when the calculated pressure is higher than the pressure, p_p , as specified in 3-4/13.

Tanks of length 54 m (177 ft) or greater that have ring webs are to have a partial non-tight bulkhead (i.e. non-full depth swash bulkhead) to eliminate the possibility of resonance at all filling levels. The partial non-tight bulkhead may be waived if it can be demonstrated through the application of model experiments or numerical simulation using three-dimensional flow analysis that sloshing impacts do not occur. The height of the swash bulkhead is to be determined on the basis of calculation using three-dimensional flow analysis as described in 3-3/13.1.1.

Where the tank length is less than 54 m (177 ft), and if either of the preventative measures given in 3-3/13.3.3 or 3-3/13.3.4 is not satisfied, the tank boundary structures are to be designed in accordance with 3-4/13 to withstand the sloshing pressures specified in 3-3/13.5.

13.3.2 Roll Induced Sloshing Loads

Tanks that do not satisfy either of the preventative measures given in 3-3/13.3.3 or 3-3/13.3.4, with respect of roll resonance, are to have their tank boundary structures designed in accordance with 3-4/13 to withstand the sloshing pressures specified in 3-3/13.5.

13.3.3

For long or wide cargo tanks, non-tight bulkheads or ring webs or both are to be designed and fitted to eliminate the possibility of resonance at all filling levels.

Long tanks have length, ℓ , exceeding $0.1L$. Wide tanks have width, b , exceeding $0.6B$.

13.3.4

For each of the anticipated loading conditions, the “critical” filling levels of the tank should be avoided so that the natural periods of fluid motions in the longitudinal and transverse directions will not synchronize with the natural periods of the installation’s pitch and roll motions, respectively. It is further recommended that the natural periods of the fluid motions in the tank, for each of the anticipated filling levels, be at least 20% greater or smaller than that of the relevant installation’s motion.

The natural period of the fluid motion, in seconds, may be approximated by the following equations:

$$T_x = (\beta_T \ell_e)^{1/2} / k \quad \text{in the longitudinal direction}$$

$$T_y = (\beta_L b_e)^{1/2} / k \quad \text{in the transverse direction}$$

where

$$\ell_e = \text{effective length of the tank, as defined in 3-3/13.5.1, in m (ft)}$$

$$b_e = \text{effective breadth of the tank, as defined in 3-3/13.5.1 in m (ft)}$$

$$k = [(\tanh H_1) / (4\pi/g)]^{1/2}$$

$$H_1 = \pi d_\ell / \ell_e \text{ or } \pi d_b / b_e$$

β_T , β_L , d_ℓ and d_b are as defined in 3-3/13.5.1. The natural periods given in 3-3/5.7 for pitch and roll of the installation, T_p and T_r , using the actual GM value, if available, may be used for this purpose.

13.5 Sloshing Pressures

13.5.1 Nominal Sloshing Pressure

For cargo tanks with filling levels within the critical range specified in 3-3/13.3.2, the internal pressures p_{is} , including static and sloshing pressures, positive toward tank boundaries, may be expressed in terms of equivalent liquid pressure head, h_e , as given below:

$$p_{is} = k_s \rho g h_e \geq 0 \quad \text{in N/cm}^2 (\text{kgf/cm}^2, \text{lbf/in}^2)$$

where

$$k_s = \text{load factor as defined in 3-3/5.7.2(a)}$$

$$h_e = \begin{cases} k_u [h_c + (h_t - h_c)(y - d_m)/(h - d_m)] & \text{for } y > d_m \\ c_m h_m + k_u h_c & \text{for } 0.15h \leq y \leq d_m \text{ (} c_m h_m \text{ need not exceed } h \text{)} \end{cases}$$

h_e calculated at $y = 0.15h$ for $y < 0.15h$, but h_e should not be smaller than $c_m h_m$.

c_m = coefficient in accordance with 3-3/11.5.3 FIGURE 15

h_m = static pressure head, taken as the vertical distance, in m (ft), measured from the filling level, d_m , down to the point considered. d_m , the filling level for maximum h_c calculated with C_{ϕ_s} and C_{θ_s} equal to 1.0, should not be taken less than $0.55h$.

d_m = filling level, in m (ft), as shown in 3-3/13.5.3 FIGURE 17

k_u = load factor, and may be taken as unity unless otherwise specified.

h_c = maximum average sloshing pressure heads, in m (ft), to be obtained from calculations as specified below for at least two filling levels, $0.55h$ and the one closest to the resonant period of ship's motions, between $0.2h$ and $0.9h$. h_c may be taken as constant over the tank depth, h (See 3-3/13.5.3 FIGURE 17)

h_t = sloshing pressure heads for upper bulkhead, in m (ft), to be obtained from calculation below

h = depth of tank, in m (ft)

y = vertical distance, in m (ft), measured from the tank bottom to the point considered

ρg is as defined in 3-3/5.7.2.

The values of h_c and h_t may be obtained from the following equations:

$$h_c = k_c(C_{\phi_s}h_\ell^2 + C_{\theta_s}h_b^2)^{1/2} \quad \text{in m (ft)}$$

$$h_t = k_c(C_{\phi_s}h_{t\ell}^2 + C_{\theta_s}h_{tb}^2)^{1/2} \quad \text{in m (ft)}$$

where

k_c = correlation factor for combined load cases, and may be taken as unity unless otherwise specified.

$$h_\ell = \phi_{es}\ell_e C_{t\ell}\beta_T[0.018 + C_{f\ell}(1.0 - d_\ell/H_\ell)/\phi_{es}]d_\ell/H_\ell \quad \text{m(ft)} \quad \text{for } \phi_{es}$$

$$h_b = \theta_{es}b_e C_{tb}\beta_L[0.016 + C_{fb}(1.0 - d_b/H_b)/\theta_{es}]d_b/H_b \quad \text{m(ft)} \quad \text{for } \theta_{es}$$

C_{ϕ_s} and C_{θ_s} are the weighted coefficients as given in 3-3/11.5.3 FIGURE 15.

where

β_T represents β for transverse bulkheads and β_L represents β for the longitudinal bulkheads.

$$\phi_{es} = 0.71\phi$$

$$\theta_{es} = 0.71\theta$$

The pitch amplitude ϕ and roll amplitude θ are as defined in 3-3/5.7.1 with $d_i = 2/3d_f$.

$$\begin{aligned} \ell_e &= \text{effective tank length that accounts for the effect of deep ring-web frames, in m (ft)} \\ &= \beta_T^* \ell \end{aligned}$$

$$b_e = \text{effective tank width that accounts for the effect of deep ring-web frames, in m (ft)}$$

$$= \beta_T^{*2} b$$

$$\beta^* = 1.0 \text{ for tanks without deep ring webs,}$$

$$= 0.25[4.0 - (1 - \alpha^*) - (1 - \alpha^*)^2] \text{ for } \alpha^* \text{ to be determined at } d_o,$$

β_T^* represents β^* for transverse bulkheads.

β_L^* represents β^* for longitudinal bulkheads.

$$\beta = (\beta_o)(\beta_u)(\beta_s)$$

β_T represents β for transverse bulkheads.

β_L represents β for longitudinal bulkheads.

$$\beta_o = 1.0 \text{ for tanks without a swash bulkhead}$$

$$= 0.25[4.0 - (1 - \alpha_o) - (1 - \alpha_o)^2] \quad \text{for tanks with a swash bulkhead}$$

$$\beta_u = 1.0 \quad \text{for tanks without any deep bottom transverse and deep bottom longitudinal girder}$$

$$= 0.25[4.0 - d_{\ell_1}/h - (d_{\ell_1}/h)^2] \quad \text{for tanks with deep bottom transverses}$$

$$= 0.25[4.0 - d_{b_1}/h - (d_{b_1}/h)^2] \quad \text{for tanks with deep bottom longitudinal girders}$$

$\beta_s = 1.0$ for boundary bulkheads that:

- i)** do not contain any deep horizontal girder; or
- ii)** do contain deep horizontal girders but with an opening ratio, α_s , less than 0.2 or greater than 0.4

$$= 0.25[4.0 - (1 - \alpha_s) - (1 - \alpha_s)^2] \text{ for bulkheads with deep horizontal girders having an opening ratio, } \alpha_s, \text{ between 0.2 and 0.4}$$

$\alpha =$ opening ratio (see 3-3/13.5.3 FIGURE 18)

For α_o 3-3/13.5.3 FIGURE 19, opening ratios of swash bulkheads, shall be used for all filling levels considered. Also, 3-3/13.5.3 FIGURE 19, local opening ratio for $d_o = 0.7h$, bounded by the range between $0.6h$ and $0.9h$, shall be considered for openings within the range. The smaller of the two opening ratios calculated, based on 3-3/13.5.3 FIGURE 19 and 3-3/13.5.3 FIGURE 19 for this filling level, shall be used as the opening ratio.

For α^* , 3-3/13.5.3 FIGURE 19, opening ratio of deep ring-webs, filling level d_o shall be used.

For α_s , 3-3/13.5.3 FIGURE 19, opening ratio of a deep horizontal girder on a boundary bulkhead, is applicable to a filling level just above the horizontal girder in the zones illustrated in the figure. Not to be considered for $d_o = 0.7h$, unless a sizable girder is installed between $0.7h$ and h . Also not to be considered if opening area in the girder is less than 20% or greater than 40% of the area of the girder (i.e., $\alpha_s = 1$)

$$C_f = 0.792[d_{\ell}/(\beta_T \ell_e)]^{1/2} + 1.98$$

$$C_{fb} = 0.704[d_b/(\beta_L b_e)]^{1/2} + 1.76$$

$$C_t = 0.9 x_o/[1 + 9(1 - x_o)^2] \geq 0.25$$

$$x_o = T_x/T_p$$

$$x_o = x_o \quad \text{if } x_o \leq 1.0$$

$$x_o = 1/x_o \quad \text{if } x_o > 1.0$$

$$C_{tb} = 0.9 y_o / [1 + 9(1 - y_o)^2] \geq 0.25$$

$$y_o = T_y / T_r \quad \text{If roll radius of gyration is not known, } 0.39B \text{ may be used in the calculation of } T_r$$

$$y_o = y_o \quad \text{if } y_o \leq 1.0$$

$$y_o = 1/y_o \quad \text{if } y_o > 1.0$$

T_x and T_y are as defined in 3-3/13.3.4.

T_p and T_r are as defined in 3-3/5.7.

$$d_o = \text{filling depth, in m (ft)}$$

$$d_\ell = d_o - d_{\ell 1} [1 - \sigma_n^2(n+1)/2]^{1/2} k_{\ell 1} - 0.45 d_{\ell 2} k_{\ell 2} \text{ and } \geq 0.0$$

$$d_b = d_o - d_{b 1} [1 - \sigma_m^2(m+1)/2]^{1/2} k_{b 1} - 0.45 d_{b 2} k_{b 2} \text{ and } \geq 0.0$$

$$H_\ell = h - d_{\ell 1} [1 - \sigma_n^2(n+1)/2]^{1/2} k_{\ell 1} - 0.45 d_{\ell 2} k_{\ell 2}$$

$$H_b = h - d_{b 1} [1 - \sigma_m^2(m+1)/2]^{1/2} k_{b 1} - 0.45 d_{b 2} k_{b 2}$$

$$d_{\ell 1} = \text{height of deep bottom transverses measured from the tank bottom, (3-3/13.5.3 FIGURE 20), in m (ft)}$$

$$d_{\ell 2} = \text{bottom height of the lowest openings in non-tight transverse bulkhead measured above the tank bottom or top of bottom transverses (3-3/13.5.3 FIGURE 20), in m (ft)}$$

$$n = \text{number of deep bottom transverses in the tank}$$

$$d_{b 1} = \text{height of deep bottom longitudinal girders measured from the tank bottom (3-3/13.5.3 FIGURE 20), in m (ft)}$$

$$d_{b 2} = \text{bottom height of the lowest openings in non-tight longitudinal bulkhead measured above the tank bottom, or top of bottom longitudinal girders (3-3/13.5.3 FIGURE 20), in m (ft)}$$

$$m = \text{number of deep bottom longitudinal girders in the tank}$$

$$k_{\ell 1} = -1 \quad \text{if } d_o \leq d_{\ell 1}$$

$$k_{\ell 1} = 1 \quad \text{if } d_o > d_{\ell 1}$$

$$k_{\ell 2} = -1 \quad \text{if } d_o \leq d_{\ell 2}$$

$$k_{\ell 2} = 1 \quad \text{if } d_o > d_{\ell 2}$$

$$k_{b 1} = -1 \quad \text{if } d_o \leq d_{b 1}$$

$$k_{b 1} = 1 \quad \text{if } d_o > d_{b 1}$$

$$k_{b 2} = -1 \quad \text{if } d_o \leq d_{b 2}$$

$$k_{b 2} = 1 \quad \text{if } d_o > d_{b 2}$$

$$\sigma_n = (4/\pi)(n+1)/[n(n+2)]\cos[\pi/2(n+1)]$$

$$\sigma_m = (4/\pi)(m+1)/[m(m+2)]\cos[\pi/2(m+1)]$$

$\ell_s(b_s)$ shall be used in place of $\ell_e(b_e)$ for a filling level below the completely solid portion of the nontight bulkhead, i.e., the region below the lowest opening, (3-3/13.5.3 FIGURE 20), where $\ell_s(b_s)$ is taken as the distance bounded by the solid portion of the nontight bulkhead below the lowest opening and the tight bulkhead. d_ℓ, H_ℓ and d_b, H_b need not consider the effect of $d_{\ell 2}$ and $d_{b 2}$, respectively.

$$h_{tl} = 0.0068\beta'_T \ell_e C'_{t\ell} (\phi_{es} + 40)(\phi_{es})^{1/2} \quad \text{m(ft)}$$

$$h_{tb} = 0.0055\beta'_L b_e C'_{tb} (\theta_{es} + 35)(\theta_{es})^{1/2} \quad \text{m(ft)}$$

where

$C'_{t\ell}$ and C'_{tb} are $C_{t\ell}$ and C_{tb} for $h_m = 0.70h$; β'_T and β'_L correspond to β for $d_o = 0.7h$; ϕ_{es} and θ_{es} are as defined previously.

C_{ϕ_s} and C_{θ_s} are weighted coefficients, as given in 3-3/11.5.3 FIGURE 15.

h_{it} shall not be less than h_p ; h_{ib} shall not be less than h_r .

$$h_p = \ell \sin(\phi_{es})$$

$$h_r = b \sin(\theta_{es})$$

13.5.2 Sloshing Loads for Assessing Strength of Structures at Tank Boundaries

13.5.2(a)

In assessing the strength of tank boundary supporting structures, the two combined load cases with loading pattern shown in 3-3/11.5.3(c), with the specified sloshing loads shown in 3-3/5.9.3 TABLE 2 for the respective side on which the horizontal girder is located, are to be considered when performing a 3D structural analysis.

13.5.2(b)

In assessing the strength of plating and stiffeners at tank boundaries, local bending of the plating and stiffeners with respect to the local sloshing pressures for structural members/elements is to be considered in addition to the nominal loadings specified for the 3D analysis in 3-3/13.5.2(a) above. In this regard, should be taken as 1.15 instead of 1.0, shown in 3-3/13.5.2(a) above for the combined load cases, to account for the maximum pressures due to possible non-uniform distribution.

13.5.3 Sloshing Loads Normal to the Web Plates of Horizontal and Vertical Girders

In addition to the sloshing loads acting on the bulkhead plating, the sloshing loads normal to the web plates of horizontal and vertical girders are to be also considered for assessing the strength of the girders. The magnitude of the normal sloshing loads may be approximated by taking 25% of h_c or h_t for $k_u = 1.0$, whichever is greater, at the location considered.

FIGURE 17
 Vertical Distribution of Equivalent Slosh Pressure Head, h_e

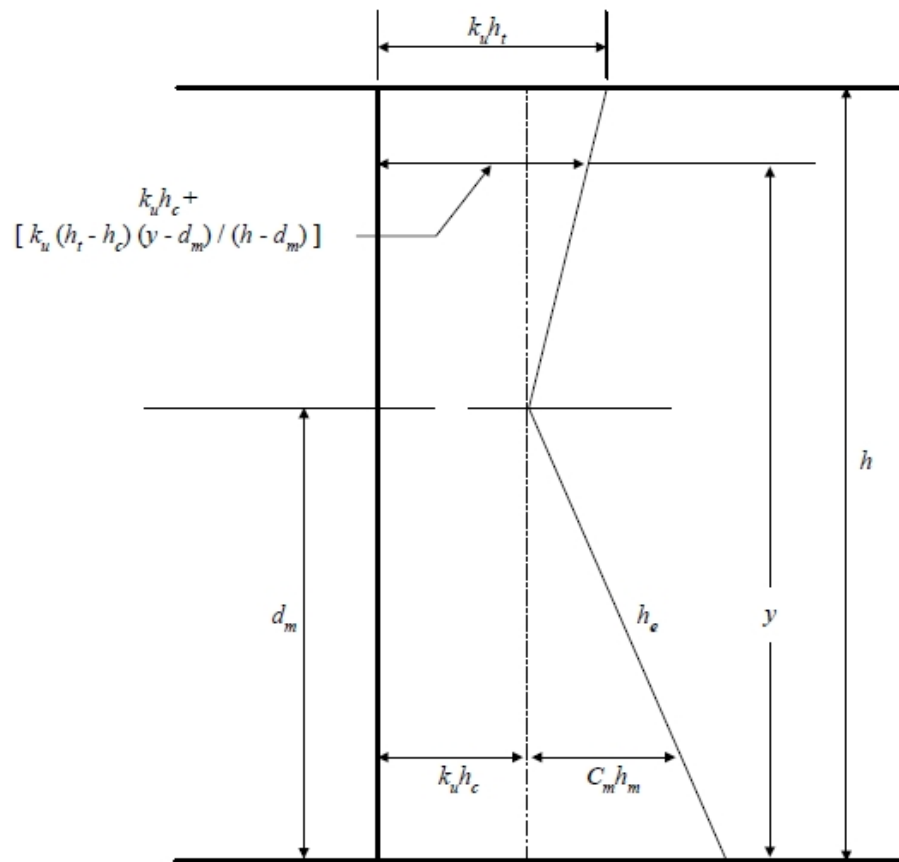

FIGURE 18
 Definitions for Opening Ratio, α

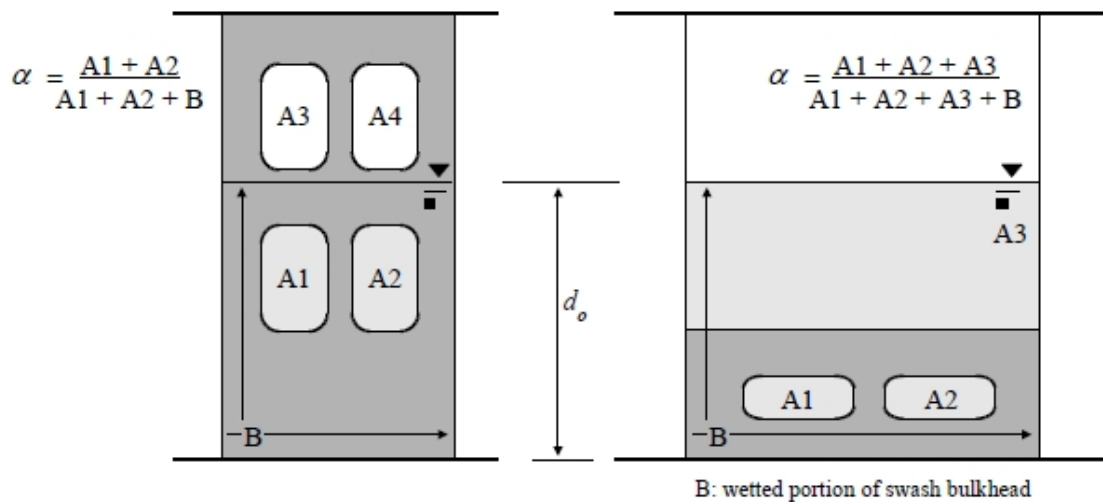
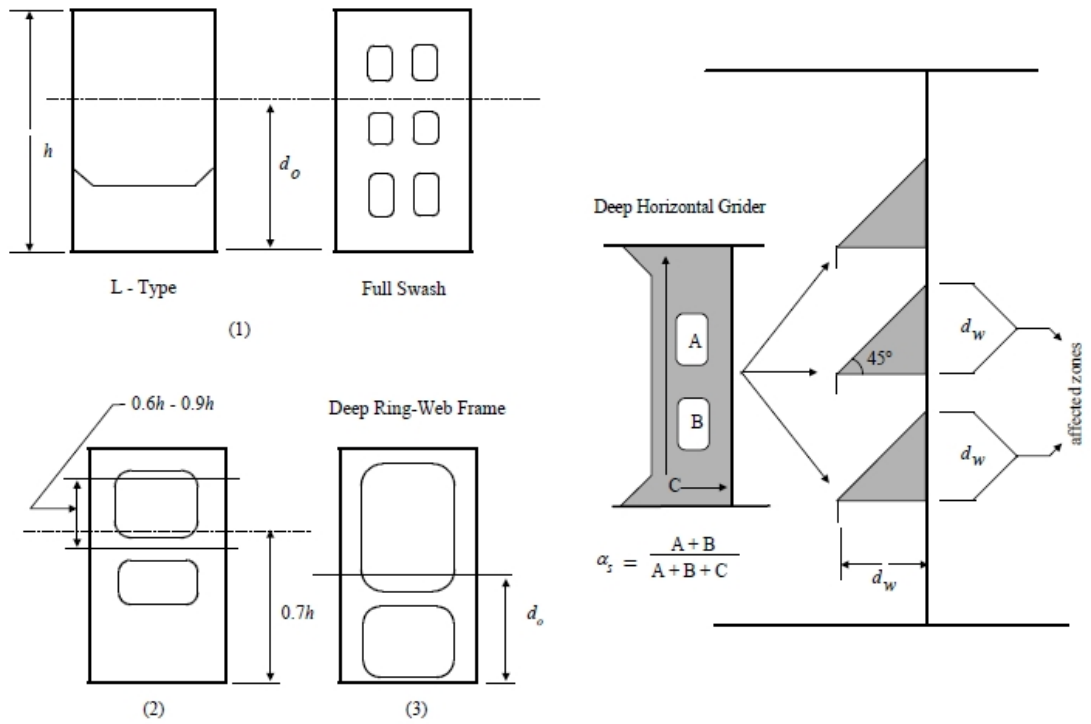

FIGURE 19
Opening Ratios



(1) – (3) Opening Ratios of Nontight Bulkheads and Deep Ring-Webs

(4) Opening Ratio of Deep Horizontal Girders Boundary Bulkheads

FIGURE 20
Dimensions of Internal Structures

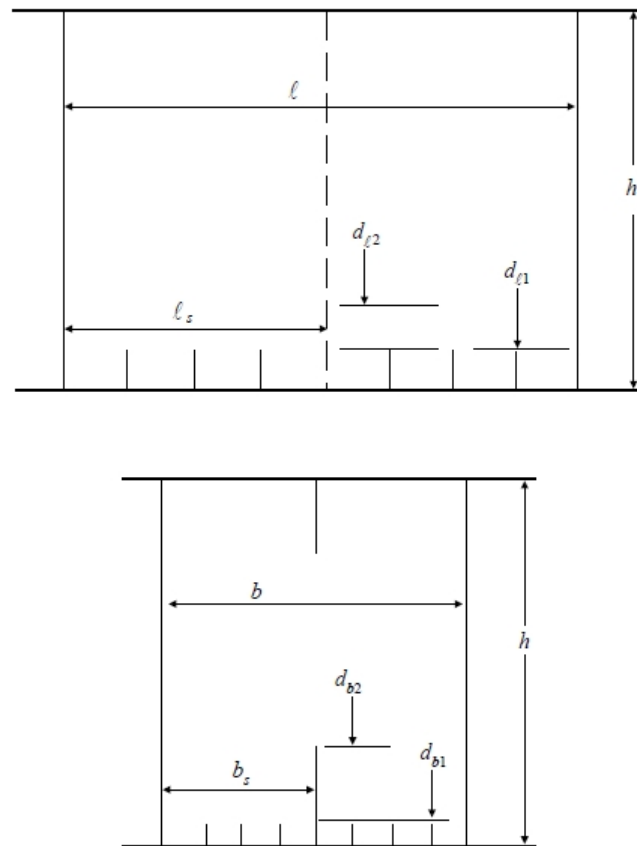

14 Thermal Loads for Prismatic Independent Tanks (1 September 2012)

14.1 General

Transient thermally induced loads during cooling down periods should be considered for tanks intended for cargo temperatures below -55°C . Stationary thermally induced loads should be considered for cargo containment systems where design supporting arrangements or attachments and operating temperature may give rise to thermal stresses. Using the finite element model for calculating structural response, as specified in 3-5/9, thermal stress analysis of a cargo tank is to be carried out to confirm the structural adequacy with respect to yielding and buckling under initial cooling down condition, partial load conditions and full load condition (98% filling).

14.3 Thermal Loading Conditions

Thermal loadings in the form of temperature distributions are to be specified in the tank structure for at least the following conditions:

14.3.1 Initial Cooling Down

Thermal load and minimum design vapor pressure are to be applied.

14.3.2 Partial Loadings

Thermal loads, static cargo pressure and minimum design vapor pressure representing partial loading conditions with filling level up to each stringer level of the tank are to be applied.

14.3.3 Full load

Thermal loads, static cargo pressure and minimum design vapor pressure for full condition (98% filling level) are to be applied.

The interaction of hull and tank structure in way of supports and chocks are to be included in all loading conditions.

14.5 Allowable Stresses

The cargo tank stresses for the thermal loading conditions are not to exceed 70% of the yield strength of the cargo tank material.

The buckling stress of all plate panels of the cargo tank is to satisfy the plate buckling requirements in 3-A2/3.

15 Impact Loads

15.1 Impact Loads on Bow

For floating liquefied gas terminals possessing significant bowflare or with a heavy ballast draft forward less than $0.04L$, the bowflare and/or bottom slamming loads are to be considered for assessing the strength of the side and bottom plating and associated stiffening system in the forebody region.

15.1.1 Bow Pressure

When experimental data or direct calculations are not available, nominal wave-induced bow pressures above LWL in the region from the forward end to the collision bulkhead may be obtained from the following equation.

$$p_{bij} = kC_kC_{ij}V_{ij}^2\sin\gamma_{ij} \quad \text{kN/m}^2 \text{ (tf/m}^2, \text{ Ltf/ft}^2\text{)}$$

where

$$k = 1.025 \text{ (0.1045, 0.000888)}$$

$$C_{ij} = 1 + \cos^2[90(F_{Bi} - 2a_{ij})/F_{Bi}]^{1/2}$$

$$V_{ij} = 10\omega_1\sin\alpha_{ij} + \omega_2(\beta_{WHT}L)^{1/2}$$

$$\omega_1 = 0.515 \text{ (1.68) for m (ft)}$$

$$\omega_2 = 1.0 \text{ (1.8)}$$

$$\beta_{WHT} = \text{ESF for wave height as defined in Chapter 3, Appendix 3}$$

$$\gamma_{ij} = \text{local bow angle measured from the horizontal, not to be taken less than } 50^\circ$$

$$= \tan^{-1}(\tan\beta_{ij}/\cos\alpha_{ij})$$

$$\alpha_{ij} = \text{local waterline angle measured from the centerline, see 3-3/15.1.1 FIGURE 21, not to be taken less than } 35^\circ$$

$$\beta_{ij} = \text{local body plan angle measured from the horizontal, see 3-3/15.1.1 FIGURE 21, not to be taken less than } 35^\circ$$

$$F_{Bi} = \text{freeboard from the highest deck at side to the load waterline (LWL) at station } i, \text{ see 3-3/15.1.1 FIGURE 21}$$

$$a_{ij} = \text{vertical distance from the LWL to } WL_j, \text{ see 3-3/15.1.1 FIGURE 21}$$

$$C_k = 0.7 \quad \text{at collision bulkhead and 0.9 at } 0.0125L, \text{ linear interpolation for in between}$$

- = 0.9 between 0.0125L and FP
- = 1.0 at and forward of FP
- i, j = station and waterline, to be taken to correspond to the locations as required by 3-6/3

FIGURE 21
Definition of Bow Geometry

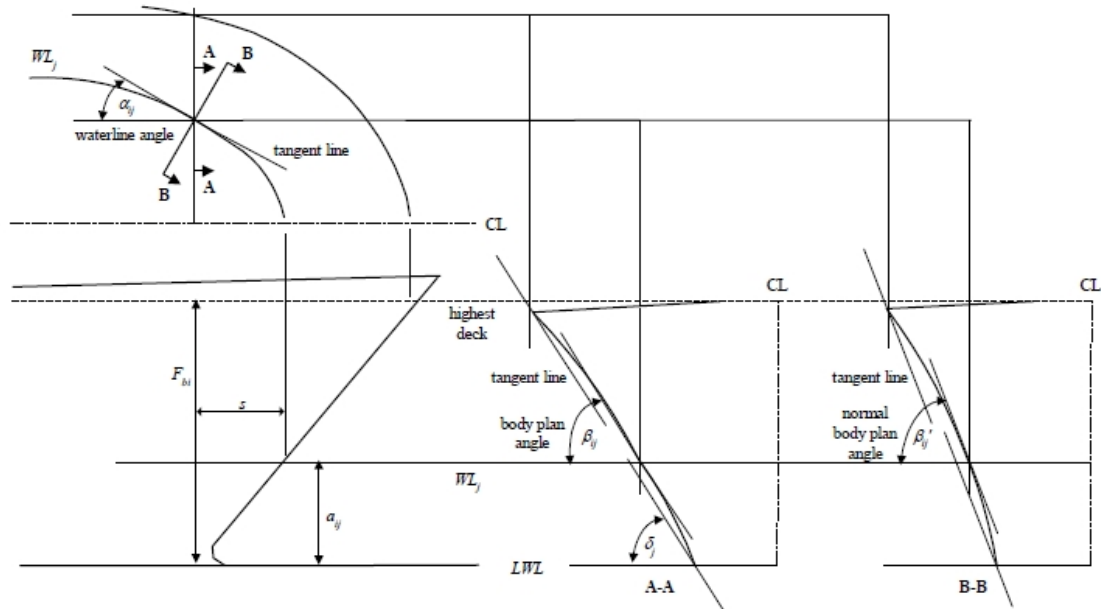

15.3 Bottom Slamming

(1 September 2012) For floating liquefied gas terminals with heavy ballast draft forward less than 0.04L, bottom slamming loads are to be considered for assessing strength of the flat bottom plating forward and the associated stiffening system in the fore body region.

15.3.1 Bottom Slamming Pressure

The equivalent bottom slamming pressure for strength formulation and assessment should be determined based on well documented experimental data or analytical studies. When these direct calculations are not available, nominal bottom slamming pressures may be determined by the following equations:

$$p_{si} = kk_i[v_o^2 + M_{Vi}E_{ni}]E_f \quad \text{kN/m}^2(\text{tf/m}^2, \text{Ltf/ft}^2)$$

where

p_{si} = equivalent bottom slamming pressure for section i

k = 1.025 (0.1045, 0.000888)

k_i = $2.2 b^*/d_o + \alpha \leq 40$

b^* = half width of flat bottom at the i -th terminal station, see 3-3/15.3.1 FIGURE 22

d_o = $1/10$ of the section draft at the heavy ballast condition, see 3-3/15.3.1 FIGURE 22

α = a constant as given in 3-3/15.3.1 TABLE 5

$$E_f = f_1 \omega_1 (L)^{1/2}$$

$$f_1 = 0.004 (0.0022) \quad \text{for m (ft)}$$

where b represents the half breadth at the $1/10$ draft of the section, see 3-3/15.3.1 FIGURE 22. Linear interpolation may be used for intermediate values.

$$v_o = c_o (L)^{1/2} \text{ m/s (ft/s)}$$

$$c_o = 0.29 (0.525)$$

$$L = \text{scantling length of floating terminal in m (ft), as defined in 3-1-1/3.1 of the } \textit{Marine Vessel Rules}$$

$$M_{Ri} = 1.391 A_i \beta_{RVM} (L/C_b)^{1/2} \quad \text{for } L \text{ in meters}$$

$$= 8.266 A_i \beta_{RVM} (L/C_b)^{1/2} \quad \text{for } L \text{ in feet}$$

$$\beta_{RVM} = \text{ESF for relative vertical motion as defined in Chapter 3, Appendix 3. Transit and on-site } \beta_{RVM} \text{ to be considered}$$

$$M_{Vi} = B_i M_{Ri}$$

A_i and B_i are as given in 3-3/15.5.1 TABLE 6.

$$G_{ei} = e^{[-v_o^2 M_{Vi} d_i^2 M_{Ri}]}]$$

$$d_i = \text{local section draft, in m (ft)}$$

$$E_{ni} = \text{natural log of } n_i$$

$$n_i = 5730 (M_{Vi}/M_{Ri})^{1/2} G_{ei}, \text{ if } n_i < 1 \text{ then } p_{si} = 0$$

$$\omega_1 = \text{natural angular frequency of the hull girder 2-node vertical vibration of the vessel in the wet mode and the heavy ballast draft condition, in rad/second. If not known, the following equation may be used.}$$

$$= \mu [BD^3 / (\Delta_s C_b^3 L^3)]^{1/2} + c_o \geq 3.7$$

$$\mu = 23400 (7475, 4094)$$

$$\Delta_s = \Delta_b [1.2 + B / (3d_b)]$$

$$\Delta_b = \text{vessel's displacement at the heavy ballast condition, in kN (tf, Ltf)}$$

$$d_b = \text{mean draft of vessel at the heavy ballast condition, in m (ft)}$$

$$c_o = 1.0 \text{ for heavy ballast draft}$$

L , B and D are as defined in Section 3-1-1 of the *Marine Vessel Rules*.

C_b is the floating terminal's block coefficient as defined in 3-2-1/3.5 of the *Marine Vessel Rules*.

TABLE 5
Values of α

b/d_o	α	b/d_o	α
1.00	0.00	4.00	20.25
1.50	9.00	5.00	22.00
2.00	11.75	6.00	23.75

b/d_o	α	b/d_o	α
2.50	14.25	7.00	24.50
3.00	16.50	7.50	24.75
3.50	18.50	25.0	24.75

FIGURE 22
Distribution of Bottom Slamming Pressure Along the Section Girth

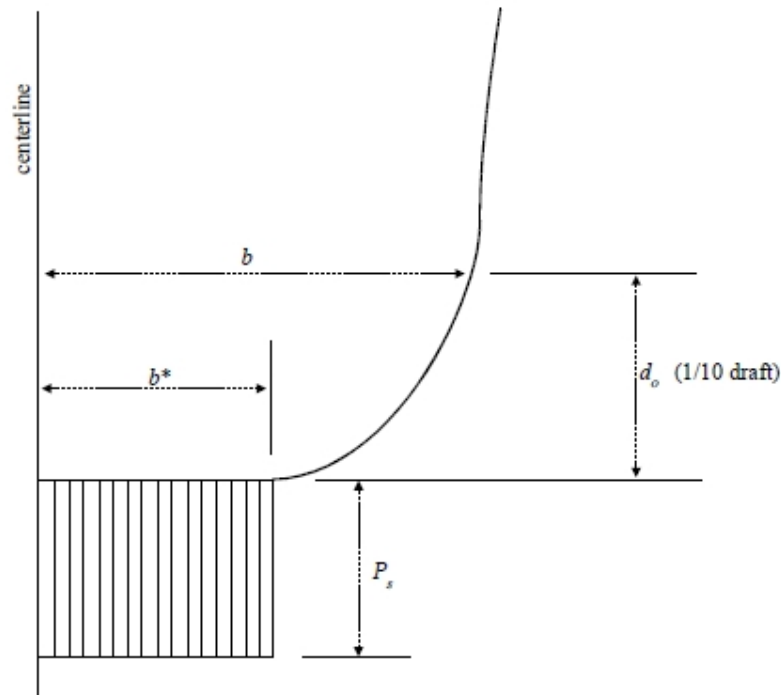

15.5 Bowflare Slamming

For vessels possessing bowflare and having a shape parameter A_r greater than 21 m (68.9 ft), in the forebody region, bowflare slamming loads are to be considered for assessing the strength of the side plating and the associated stiffening system in the forebody region of the vessel at its scantling draft.

A_r = maximum value of A_{ri} in the forebody region

A_{ri} = bowflare shape parameter at a station i forward of the quarter length, up to the FP of the vessel, to be determined between the load waterline (LWL) and the upper deck/ forecastle as follows:
 $(b_r/H)^2 \sum b_j [1 + (s_j/b_j)^2]^{1/2}, j = 1, n; n \geq 3$

where

n = number of segments

b_T = $\sum b_j$

H = $\sum s_j$

b_j = local change (increase) in beam for the j -th segment at station i (see 3-3/15.5.2 FIGURE 23)

s_j = local change (increase) in freeboard up to the highest deck for the j -th segment at station i forward (see 3-3/15.5.2 FIGURE 23)

15.5.1 Nominal Bowflare Slamming

When experimental data or direct calculation is not available, nominal bowflare slamming pressures may be determined by the following equations:

$p_{ij} = p_{oij}$ or p_{bij} as defined below, whichever is greater

$$P_{oij} = k_1(9M_{Ri} - h_{ij}^2)^{1/2} \quad \text{kN/m}^2 \text{ (tf/m}^2, \text{ Ltf/ft}^2\text{)}$$

$$P_{bij} = k_2k_3[C_2 + K_{ij}M_{Vi}(1 + E_{ni})] \quad \text{kN/m}^2 \text{ (tf/m}^2, \text{ Ltf/ft}^2\text{)}$$

where

$$k_1 = 9.807 \text{ (1, 0.0278)}$$

$$M_{Ri} = 1.391 A_i \beta_{RVM} (L/C_b)^{1/2} \quad \text{for } L \text{ in meters, if } 9M_{Ri} < h_{ij}^2, \text{ then } P_{oij} = 0$$

$$= 8.266 A_i \beta_{RVM} (L/C_b)^{1/2} \quad \text{for } L \text{ in feet, if } 9M_{Ri} < h_{ij}^2, \text{ then } P_{oij} = 0$$

A_i = coefficient as given in 3-3/15.5.1 TABLE 6.

β_{RVM} = ESF for relative vertical motion as defined in Chapter 3, Appendix 3

L = distance in meters (feet) on the summer load line from the fore side of the stem to the centerline of the rudder stock. For use with the *Marine Vessel Rules*, L is not to be less than 96% and need not be greater than 97% of the length on the summer load line. The forward end of L is to coincide with the fore side of the stem on the waterline on which L is measured.

C_b = block coefficient, as defined in 3-1-1/11.3 of the *Marine Vessel Rules*, but is not to be taken less than 0.6

h_{ij} = vertical distance measured from the load waterline (LWL) at station i to WL_j on the bowflare. The value of h_{ij} is not to be taken less than h_b^* . P_{bij} at a location between LWL and h_b^* above LWL need not be taken greater than p_{bij}^* .

$$h_b^* = 0.005(L - 130) + 3.0 \text{ (m)} \quad \text{for } L < 230 \text{ m}$$

$$= 0.005(L - 426.4) + 9.84 \text{ (ft)} \quad \text{for } L < 754 \text{ ft}$$

$$= 7.143 \times 10^{-3}(L - 230) + 3.5 \text{ (m)} \quad \text{for } 230 \text{ m} \leq L < 300 \text{ m}$$

$$= 7.143 \times 10^{-3}(L - 754.4) + 11.48 \text{ (ft)} \quad \text{for } 754 \text{ ft} \leq L < 984 \text{ ft}$$

$$= 4.0 \text{ m (13.12 ft)} \quad \text{for } L \geq 300 \text{ m (984 ft)}$$

$$P_{bij}^* =$$

$$P_{bij}^* = P_{bij} \text{ at } h_b^* \text{ above } LWL$$

β'_{ij} = normal local body plan angle as shown in 3-3/15.1.1 FIGURE 21, in degrees

$$= \tan^{-1}[\tan(\beta_{ij})/\cos(\alpha_{ij})]$$

$$\beta_i^* = \beta'_{ij} \text{ at } h_b^* \text{ above } LWL$$

β_{ij} = local body plan angle measured from the horizontal, in degrees, need not be taken less than 75° , see 3-3/15.5.2 FIGURE 23

α_{ij} = waterline angle as in 3-3/15.1.1 FIGURE 21

$$k_2 = 1.025 \text{ (0.1045, 0.000888)}$$

$$k_3 = 1 \quad \text{for } h_{ij} \leq h_b^*$$

$$= 1 + (h_{ij}/h_b^* - 1)^2 \quad \text{for } h_b^* < h_{ij} < 2 h_b^*$$

$$= 2 \quad \text{for } h_{ij} \geq 2 h_b^*$$

- $C_2 = 39.2 (422.46)$ for m (ft)
 $K_{ij} = f_{ij} [r_j / (bb_{ij} + 0.5h_{ij})]^{3/2} [\ell_{ij} / r_j] [1.09 + 0.029V - 0.47C_b]^2$
 $f_{ij} = [90/\beta'_{ij} - 1]^2 [\tan^2(\beta'_{ij})/9.86] \cos \gamma$
 $\gamma =$ stem angle at the centerline measured from the horizontal, 3-3/15.5.2 FIGURE 24, in degrees, not to be taken greater than 75°
 $r_j = (M_{Ri})^{1/2}$
 $bb_{ij} = b_{ij} - b_{i0} > 2.0 (6.56)$ m (ft)
 $b_{ij} =$ local half beam of location j at station i
 $b_{i0} =$ local waterline half beam at station i
 $\ell_{ij} =$ longitudinal distance of WL_j at station i measured from amidships
 $M_{Vi} = B_i M_{Ri}$
 $B_i =$ coefficient as given in 3-3/Table 6
 $E_{ni} =$ natural log of n_{ij}
 $n_{ij} = 5730(M_{Vi}/M_{Ri})^{1/2} G_{ij} \geq 1.0$
 $G_{ij} = e^{(-h_{ij}^2/M_{Ri})}$

TABLE 6
Values of A_i and B_i^*

	A_i	B_i
-0.05L	1.25	0.3600
FP	1.00	0.4000
0.05L	0.80	0.4375
0.10L	0.62	0.4838
0.15L	0.47	0.5532
0.20L	0.33	0.6666
0.25L	0.22	0.8182
0.30L	0.22	0.8182

* Linear interpolation may be used for intermediate values.

15.5.2 Simultaneous Bowflare Slamming Pressure

For performing structural analyses to determine overall responses of the hull structures, the spatial distribution of instantaneous bowflare slamming pressures on the fore body region of the hull may be expressed by multiplying the calculated maximum bowflare slamming pressures, p_{ij} , at forward vessel stations by a factor of 0.71 for the region between the stem and 0.3L from the FP.

FIGURE 23
 Definition of Bowflare Geometry for Bowflare Shape Parameter

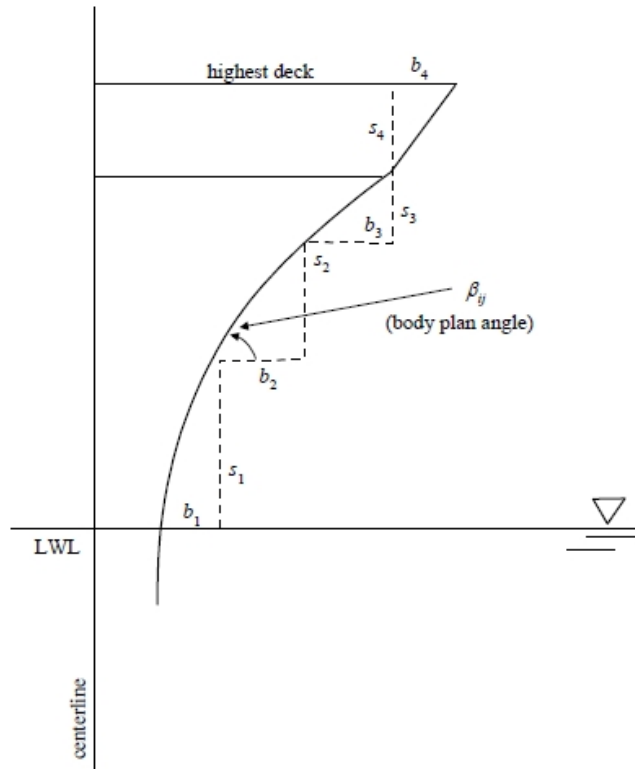
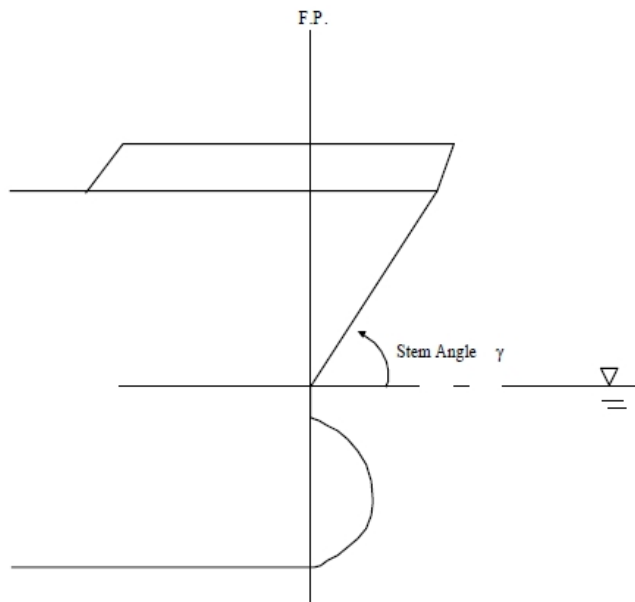

FIGURE 24
 Stem Angle, γ



15.7 Green Water on Deck

When experimental data or direct calculations are not available, nominal green water pressure imposed on deck along the terminal’s length, including the extension beyond the FP, may be obtained from the following equations.

$$P_{gi} = K\{[\beta_{RVM}A_i(B/L)^{1/4}/C_b] - k_1F_{bi}\} \quad \text{kN/m}^2 \text{ (tf/m}^2, \text{ Lt/ft}^2\text{)}$$

where

- P_{gi} = green water pressure, uniformly distributed across the deck at specified longitudinal section i along the terminal’s length under consideration (see 3-3/15.7 TABLE 7 below). Pressure in between is obtained by linear interpolation. P_{gi} is not to be taken less than 20.6 kN/m² (2.1 tf/m², 0.192 Lt/ft²).
- K = 10.052 (1.025, 0.09372)
- k_1 = 1.0 (3.28) for m (ft)
- A_i = as shown in 3-3/15.7 TABLE 7
- β_{RVM} = ESF factor of relative vertical motion, as defined in Chapter 3, Appendix 3 Transit and on-site β_{RVM} to be considered.
- C_b = as defined in 3-2-1/3.5 of the *Marine Vessel Rules*
- L = scantling length of floating terminal, in m (ft), as defined in 3-1-1/3.1 of the *Marine Vessel Rules*
- B = greatest molded breadth of floating terminal, in m (ft), as defined in 3-1-1/5 of the *Marine Vessel Rules*
- F_{B_i} = freeboard from the highest deck at side to the load waterline (LWL) at station i , in m (ft), see 3-3/15.1.1 FIGURE 21

TABLE 7
Values of A_i

Section i from F.P.	A_i
-0.05L	23.3
0	20.7
0.05L	18.2
0.10L	16.1
0.15L	14.7
0.20L	14.3
0.25L	14.2
0.30L	14.1
0.35L	14
0.40L	14
0.45L	14
0.50L	14
0.55L	14

<i>Section i from F.P.</i>	A_i
0.60L	14
0.65L	14
0.70L	14
0.75L	14.2
0.80L	14.2
0.85L	14.2
0.90L	14.7
0.95L	17.1
1.00L	19.9

17 Deck Loads

17.1 General

For the design and evaluation of deck structures, the following loads due to on deck production facilities are to be considered:

- i) Static weight of on deck production facilities in upright condition
- ii) Dynamic loads due to vessel motions
- iii) Wind load

17.3 Loads for On-Site Operation

The nominal forces from each individual deck production module at the center of gravity of the module can be obtained from the following equations:

$$F_v = W[\cos(0.71C_\phi\phi)\cos(0.71C_\theta\theta) + 0.71c_v a_v/g]$$

$$F_t = W[\sin(0.71C_\theta\theta) + 0.71c_T a_t/g] + k_t F_{wind}$$

$$F_\ell = W[-\sin(0.71C_\phi\phi) + 0.71c_L a_\ell/g] + k_\ell F_{wind}$$

where

ϕ and θ are the pitch and roll amplitudes defined in 3-3/5.7.1.

ϕ , in degrees, need not to be taken more than 10 degrees.

θ , in degrees, need not to be taken more than 30 degrees.

a_v , a_t and a_ℓ are the vertical, transverse and longitudinal accelerations, as specified in 3-3/5.7.1 for heading angles μ in 3-3/17.3 TABLE 8

Note:

The accelerations specified in 3-3/5.7.1 are to be considered preliminary values and may be used only when values from model tests or vessel motion calculations are not yet available. The final design forces from deck production modules are to be calculated using acceleration values obtained from model test data or vessel motions calculations for the site location.

- F_v = vertical load from each production module, positive downward
- F_t = transverse load from each production module, positive starboard
- F_ℓ = longitudinal load from each production module, positive forward
- W = weight of the production module, in kN (tf, Ltf)
- $F_{wind} = kA_{wind} C_s C_h V_{wind}^2$ = wind force, in kN (tf, Ltf)

Two combinations of wave-induced and wind forces are to be considered:

F_v, F_t with factor $k_t = 1$ and F_ℓ with factor $k_\ell = 0$

F_v, F_t with factor $k_t = 0$ and F_ℓ with factor $k_\ell = 1$

The deck load is to be obtained for the maximum weight of on deck production facilities for head sea (Load Case A), beam sea (Load Case B) and oblique sea (Load Case C) listed in 3-3/17.3 TABLE 8, where the correlation factors c_v, c_T, c_L, C_ϕ and C_θ for each load case are also shown.

TABLE 8
Correlation Factors c_v, c_T, c_L, C_ϕ and C_θ

Load Case	LC A (head sea)	LC B (beam sea)	LC C (oblique)
c_v	0.8	0.4	0.7
c_L	0.6	0	0.7
c_T	0	0.9	0.7
C_ϕ	-1	0	-0.7
C_θ	0	1	0.7
Wave heading angle μ in deg.	0	90	60

where

- V_{wind} = wind velocity based on 1-hour average speed
- A_{wind} = projected area of windage on a plane normal to the direction of the wind, in m² (ft²)
- C_s = shape coefficient, defined in Section 3-2-4 of the *FPI Rules*
- C_h = height coefficient, defined in Section 3-2-4 of the *FPI Rules* for 1-hour average wind

The forces from each deck production module can be obtained based on long-term prediction for the realistic sea states of the specific site of operation. In no case are the forces F_v, F_t and F_ℓ to be less than those obtained using the values of Environmental Severity Factors (ESFs) established from 3-A3/3.

17.5 Loads in Transit Condition

Nominal loads of the production facility modules on deck during transit condition can be obtained from the equations in item 3-3/17.3, above. Alternatively, corresponding forces can be calculated based on the sea condition for the specific voyage.

17.7 Temperature Loads

Transient thermal loads during cooling down periods are to be considered for cargo tanks intended for cargo temperatures below -55°C.

Stationary thermal loads are to be considered for tanks where design supporting arrangement and operating temperature may give rise to significant thermal stresses.

CHAPTER 3 Structural Design Requirements

SECTION 4 Initial Scantling Criteria

1 General

1.1 Strength Requirement

This Section specifies the minimum strength requirements for the hull structure with respect to the determination of initial scantlings, including the hull girder, shell and bulkhead plating, longitudinals/stiffeners and main supporting members. Once the minimum scantlings are determined, the strength of the resulting design is to be assessed in accordance with Chapter 3, Section 5. The assessment is to be carried out by means of an appropriate structural analysis as per 3-5/9, in order to establish compliance with the failure criteria in 3-5/3. Structural details are to comply with 3-4/1.5.

The requirements for hull girder strength are specified in 3-4/3. The required scantlings of the double bottom structure, the side shell and deck, and the longitudinal and transverse bulkheads are specified in 3-4/7 through 3-4/15. The required scantlings of the supporting hull structure of the tanks such as inner bottom, inner deck, inner longitudinal and transverse bulkhead structures are also designed using the IGC based internal pressures. These pressures can be obtained using appropriate ESF β factors as specified in 3-3/5.9. For hull structures beyond $0.4L$ amidships the initial scantlings are determined in accordance with Chapter 3, Section 6.

1.3 Calculation of Load Effects

Equations giving approximate requirements are given in 3-4/7 through 3-4/15 for calculating the design bending moments and shear forces for main supporting members. These local load effects may be determined from a 3D structural analysis at the early design stages, as outlined in 3-5/9 for the additional IGC load cases specified in 3-3/9. In this regard, the detailed analysis results are to be submitted for review.

1.5 Structural Details

The strength criteria specified in this Section and Chapter 3, Section 6 are based on assumptions that all structural joints and welded details are properly designed and fabricated and are compatible with the anticipated working stress levels at the locations considered. The loading patterns, stress concentrations and potential failure modes of structural joints and details should be closely examined during the design of highly stressed regions. In this evaluation, failure criteria specified in 3-5/3 may be used to assess the adequacy of structural details.

1.7 Evaluation of Grouped Stiffeners

Where several members in a group with some variation in requirement are selected as equal, the section modulus requirement may be taken as the average of each individual requirement in the group. However, the section modulus requirement for the group is not to be taken less than 90% of the largest section modulus required for individual stiffeners within the group. Sequentially positioned stiffeners of equal scantlings may be considered a group.

3 Hull Girder Strength

The longitudinal strength is to be based on Section 3-2-1 of the *Marine Vessel Rules* with modifications as indicated below for terminals classed with **(S)** notation.

3.1 Still-water Loads

Still-water bending moment and shear force calculations for all anticipated loading conditions during on-site and in-transit operation are to be submitted together with the distribution of light weights.

The influence of mooring equipment, riser weights and topside loads on the still-water bending moments and shear forces is to be taken into consideration in these calculations.

3.3 Wave Induced Loads

3.3.1 Direct Calculation

Wave-induced bending moments and shear forces may be determined from Section 3-2-3 of the *FPI Rules* for the on-site and transit conditions, respectively, subject to the minimum as specified below.

3.3.2 Environmental Severity Factor (ESF) Approach

In lieu of direct calculation, where a floating terminal is sited at a location with dynamic load components that are less than those arising from unrestricted service conditions of a seagoing wave-induced bending moments and shear forces in on-site condition may be calculated by the Environmental Severity Factor (ESF) approach, as described in 3-3/1 and Chapter 3, Appendix 3. This approach can be applied to modify the wave-induced hull girder bending moment and shear force formulas for unrestricted service, as specified in 3-3/5.

3.5 Hull Girder Section Modulus

3.5.1 Section Modulus (1 June 2014)

The required hull girder section modulus for 0.4L amidships is to be the greater of the values obtained from the following equation or the minimum section modulus SM_{min} in 3-4/3.5.2:

$$SM = M_t / f_p \quad \text{cm}^2 - \text{m} \quad (\text{in}^2 - \text{ft})$$

where

M_t = total bending moment, as described below

f_p = nominal permissible bending stress within 0.4L amidships

= 17.5 kN/cm² (1.784 tf/cm², 11.33 Ltf/in²)

= nominal permissible bending stress forward of 0.9L from A.P. and aft of 0.1L from A.P.

= 12.5 kN/cm² (1.274 tf/cm², 8.09 Ltf/in²)

Linear interpolation is to be used for the intermediate location.

The total bending moment, M_t is to be considered as the maximum algebraic sum of the maximum still-water bending moment (M_{sw}) for operation on site or in transit combined with the corresponding wave-induced bending moment (M_w) expected on-site and during transit to the terminal site. In lieu of directly calculated wave-induced hull girder vertical bending moments and shear forces, recourse can be made to the use of the Environmental Severity Factor (ESF) approach, which can be applied to modify the *Marine Vessel Rules* wave-induced hull girder bending moment and shear force formulas (see 3-3/5 of this Guide).

3.5.2 Minimum Section Modulus

Depending on the value of the Environmental Severity Factor, β_{vbm} for vertical wave-induced hull girder bending moment (see Chapter 3, Appendix 3 of this Guide), the minimum hull girder section modulus SM_{min} of the floating terminal, as specified in 3-2-1/3.7.1(b) of the *Marine Vessel Rules*, may vary in accordance with the following:

β_{vbm}	SM_{min}
< 0.7	$0.85SM_{mvr}$
0.7 to 1.0	$(0.5 + \beta_{vbm}/2)SM_{mvr}$
> 1.0	SM_{mvr}

Where SM_{mvr} = minimum hull girder section modulus as required in 3-2-1/3.7.1(b) of the *Marine Vessel Rules*

3.5.3 Effective Longitudinal Members

The hull girder section modulus calculation is to be carried out in accordance with 3-2-1/9 of the *Marine Vessel Rules*, as modified below. To suit the strength criteria based on a “net” scantling concept, the nominal design corrosion values specified in 3-2/Table 1 are to be deducted in calculating the net section modulus, SM_n .

3.5.4 Extent of Midship Scantlings

The items included in the hull girder section modulus amidships are to be extended as necessary to meet the hull girder section modulus required at the location being considered. The required hull girder section modulus can be obtained as M_t/f_p at the location being considered except if $(M_t)_{max}/f_p$ is less than SM_{min} in 3-4/3.5.2. In this case, the required section modulus is to be obtained by multiplying SM_{min} by the ratio of $M_{ti}/(M_t)_{max}$ where M_{ti} is the total bending moment at the location under consideration and $(M_t)_{max}$ is the maximum total bending moment amidships.

3.5.5 Membrane Strain Control

The containment system manufacturer may have explicit limits on hull girder stress that may control the minimum required hull girder section modulus. These limits are to be met in the design of the hull structure.

3.7 Hull Girder Moment of Inertia

The hull girder moment of inertia, I , amidships, is to be not less than:

$$I = L \cdot SM / 33.3 \quad \text{cm}^2 - \text{m}^2 \text{ (in}^2 - \text{ft}^2\text{)}$$

where

- L = length of floating terminal, as defined in 3-1-1/3.1 of the *Marine Vessel Rules*, in m (ft)
 SM = required hull girder section modulus, in $\text{cm}^2\text{-m}$ ($\text{in}^2\text{-ft}$). See 3-4/3.5.

3.9 Hull Girder Ultimate Strength

In addition to the strength requirements specified in 3-4/3.5, the vertical hull girder ultimate strength for either hogging or sagging conditions for the floating liquefied gas terminal design environmental condition (DEC) is to satisfy the limit state as specified below. It need only be applied within the $0.4L$ amidships region.

$$\gamma_s M_s + \gamma_w \beta_{VBM} M_w \leq M_u / \gamma_u$$

where

- M_s = permissible still-water bending moment, in kN-m (tf-m , Ltf-ft)
 M_w = vertical wave-induced bending moment in accordance with 3-3/5.1.1, in kN-m (tf-m , Ltf-ft)
 M_u = hull girder ultimate strength, which may be determined from the equations as given in Chapter 3, Appendix 4, in kN-m (tf-m , Ltf-ft)
 β_{VBM} = ESF for vertical wave-induced bending moment for DEC
 γ_s = load factor for the maximum permissible still-water bending moment, but not to be taken as less than 1.0
 γ_w = load factor for the wave-induced bending moment, but not to be taken as less than below for the given limits
 = 1.3 for $M_s < 0.2M_t$ or $M_s > 0.5M_t$
 = 1.2 for $0.2M_t \leq M_s \leq 0.5M_t$
 M_t = total bending moment, in kN-m (tf-m , Ltf-ft)
 = $M_s + \beta_{VBM} M_w$
 γ_u = safety factor for the vertical hull girder bending capacity, but not to be taken as less than 1.15

3.11 Minimum Scantlings for ESF Approach

When applying the ESF approach in the calculation of a required scantling, the scantling is not to be less than 85% of the scantling determined by the *Marine Vessel Rules* for unrestricted service.

3.13 Loading Manual

A loading manual based on still-water conditions is to be prepared and submitted for review. See 2-1/15 of this Guide for general requirements pertaining to the makeup and issuance of the loading guidance with respect to hull girder strength. A loading instrument is also required.

5 Shearing Strength

5.1 General

The net thickness of the side shell t_s and the net thickness of the longitudinal bulkhead plating t_i , is to be determined based on the total vertical shear force F_t , and the permissible shear stress f_s , given below:

$$t = kFm / If_s \quad \text{mm(in.)}$$

where

- t = t_s or t_i as appropriate (see also 3-4/5.3 and 3-4/5.5)
- k = 10.0 (10.0, 1.0)
- F = $F_t D_s$ or $(F_t + R_i) D_i$ in kN (tf, Ltf)
- F_t = $F_S + \beta_{VSF} F_W$ kN (tf, Ltf)
- m = first moment of the “net” hull girder section, in cm^3 (in^3), about the neutral axis, of the area between the vertical level at which the shear stress is being determined and the vertical extremity of the section under consideration
- I = moment of inertia of the “net” hull girder section at the position considered, in cm^4 (in^4)
- f_s = $11.96/Q$ kN/cm² ($1.220/Q$ tf/cm², $7.741/Q$ Ltf/in²) at sea
 = $10.87/Q$ kN/cm² ($1.114/Q$ tf/cm², $7.065/Q$ Ltf/in²) in port
- Q = material conversion factor
 = 1.0 for ordinary strength steel
 = 0.78 for H32 strength steel
 = 0.72 for H36 strength steel
 = 0.68 for H40 strength steel
- F_S = still-water shear force based on the still-water shear force envelope curve for all anticipated loading conditions in accordance with 3-2-1/3.3 of the *Marine Vessel Rules*, at location considered, in kN (tf, Ltf).
- F_W = vertical wave shear force, in kN (tf, Ltf), as given in 3-3/5.1.3. F_W for in-port condition may be taken as zero.
- β_{VSF} = ESF for vertical shear force, as defined in Chapter 3, Appendix 3
- D_s = shear distribution factor for the side shell
- D_i = shear distribution factor for the longitudinal bulkheads, where i is defined below:
- i = *ob* for outer longitudinal bulkhead (inner skin)
 = *cb* for cofferdam longitudinal bulkhead

D_s and D_{ob} may be obtained from the equations in 3-4/5.3 and 3-4/5.5 when a direct calculation is not available to determine the shear distribution between side shell and outer longitudinal bulkhead and where the outer longitudinal bulkhead is located no further than 0.075B from the side shell.

For the purpose of calculating the required thickness for hull girder shear, the sign of F_t may be disregarded unless algebraic sum with other shear forces, such as local load components, is appropriate.

The nominal design corrosion values given in 3-2/Table 1 for the side shell and longitudinal bulkhead plating are to be added to the “net” thickness.

5.3 Net Thickness of Side Shell Plating

$$t_s = k F_t D_s m / I f_s \text{ mm(in.)}$$

where

D_s = shear distribution factor for side shell, as defined in 3-4/5.3.1 or 3-4/5.3.2 below.

F_t, m, k, I and f_s are as defined in 3-4/5.1 above.

5.3.1 Shear Distribution Factor for Floating Terminals with Two Outer Longitudinal Bulkheads (inner skin only)

$$D_s = 0.384 - 0.167 A_{ob}/A_s - 0.190 b_s/B$$

where

A_{ob} = total projected area of the net outer longitudinal bulkhead (inner skin) plating above inner bottom (one side), in cm^2 (in^2)

A_s = total projected area of the net side shell plating (one side), in cm^2 (in^2)

b_s = distance between outer longitudinal bulkhead (inner skin) and side shell, in m (ft)

B = breadth of the vessel, in m (ft), as defined in 3-1-1/5 of the *Marine Vessel Rules*

5.3.2 Shear Distribution Factor for Floating Terminals with Two Outer and Two Cofferdam Longitudinal Bulkheads

$$D_s = 0.330 - 0.218 A_{ob}/A_s - 0.043b_s/B$$

where A_{ob}, A_s, b_s and B are as defined in 3-4/5.3.1 above.

5.5 Net Thickness of Longitudinal Bulkheads

$$t_i = k(F_t + R_i)D_i m / I f_s \quad \text{mm (in.)}$$

where

D_i = shear distribution factor for longitudinal bulkhead

R_i = local load correction

i = *ob* for outer longitudinal bulkhead (inner skin)

= *cb* for cofferdam longitudinal bulkhead

F_t, m, k, I , and f_s are as defined in 3-4/5.1 above.

The other parameters, depending on the tank configuration of the floating terminal, center tank or two tanks abreast, are defined in 3-4/5.5.1 and 3-4/5.5.2 below.

5.5.1 Floating Terminals with Two Outer Longitudinal Bulkheads (Inner Skin Only)

The net thickness of the outer longitudinal bulkhead plating at the position considered:

$$t_{ob} = kF_t D_{ob} m / I f_s \quad \text{mm(in.)}$$

where

$$D_{ob} = 0.116 + 0.167 A_{ob}/A_s + 0.190 b_s/B$$

$A_s, A_{ob}, b_s, B, F_t, I, k, m$ and f_s are defined above.

5.5.2 Floating Terminals with Two Outer and Two Cofferdam Longitudinal Bulkheads

5.5.2(a) The net thickness of the cofferdam longitudinal bulkhead plating at the position considered:

$$t_{ib} = k(F_t + R_{cb})D_{cb}m/If_s \quad \text{mm (in.)}$$

where

$$R_{cb} = W_c[(2N_{wcb}k_{cb}I/3H_{cb}D_{cb}m) - 1] \geq 0$$

W_c = local load, in kN (tf, Ltf), calculated according to 3-4/5.7 and 3-4/Figure 1B, for membrane tank containment system

= 0.0 for independent tank containment system

N_{wcb} = local load distribution factor for the cofferdam longitudinal bulkhead

$$= (0.66D_{cb} + 0.25)(n - 1)/n$$

n = total number of transverse frame spaces in the center tank

$$k_{cb} = 1 + A^*_{cb}/A_{cb} \leq 1.9$$

A^*_{cb} = total area of the net cofferdam longitudinal bulkhead plating above the lower edge of the strake under consideration, in cm² (in²)

A_{cb} = total projected area of the net cofferdam longitudinal bulkhead plating in cm² (in²)

H_{cb} = depth of the cofferdam longitudinal bulkhead above inner bottom, in cm (in.)

$$D_{cb} = 0.064 + 0.093A_{cb}/A_s + 0.054A_{ob}/A_s - 0.159b_s/B$$

All other parameters are as defined in 3-4/5.3.

5.5.2(b) The net thickness of the outer longitudinal bulkhead plating at the position considered:

$$t_{ob} \geq F_t D_{ob}m/If_s \quad \text{cm(in.)}$$

where

$$D_{ob} = 0.106 - 0.093A_{cb}/A_s + 0.164A_{ob}/A_s + 0.202b_s/B$$

All other parameters are as defined in 3-4/5.3 and 3-4/5.5.

5.7 Calculation of Local Loads

In determining the shear forces at the ends of cargo tanks, the local loads are to be calculated as shown in the following example. The tank arrangement for this example is as shown in 3-4/Figure 1B. The ballast tanks within double bottom and double side are to be considered as being empty in calculating excess liquid head.

5.7.1 Floating Terminals with Two Outer and Two Cofferdam Longitudinal Bulkheads (1 September 2012)

Local load W_c may be denoted by $W_c(f)$ and $W_c(a)$ at the fore and aft ends of the cargo tank, respectively, in kN (tf, Ltf).

$$W_c(f) = W_c(a) = \rho g b_{c1} \ell_c [H_c + 0.71\beta_{VAC}(a_v/g)H_c + 0.47\ell_c \sin(\beta_{PMO}\Phi) - 0.55(\rho_o/\rho)d_f + 0.2(\rho_o/\rho)C_1] \geq 0$$

but need not be taken greater than $\rho g b_{c1} \ell_c H_c$

where

- ρg = Specific weight of the liquid, not to be taken less than 4.9 kN/m³ (0.5 tf/m³, 0.0139 Ltf/ft³)
- $\rho_o g$ = specific weight of sea water, 10.05 kN/m³ (1.025 tf/m³, 0.0286 Ltf/ft³)
- $\ell_c b_{c1}$ = length and breadth, respectively, of the cargo tanks, in m (ft), as shown in 3-4/Figure 1B
- H_c = liquid head in the cargo tank, in m (ft)
- a_v = vertical acceleration amidships with a wave heading angle of 0 degrees, in m/sec² (ft/sec²), as defined in 3-3/5.7.1(c)
- g = acceleration of gravity = 9.8 m/sec² (32.2 ft/sec²)
- ϕ = pitch amplitude in degrees, as defined in 3-3/5.7.1(a)
- d_f = draft, as defined in 3-1-1/9 of the *Marine Vessel Rules*, in m (ft)
- C_1 = as defined in 3-3/5.1.1
- β_{VAC} = ESF for vertical acceleration, as defined in Chapter 3, Appendix 3
- β_{PMO} = ESF for pitch motion, as defined in Chapter 3, Appendix 3

For locations away from the ends of the tanks, R_{cb} and R_{ib} may be determined using the calculated values of W_c at the locations considered.

5.9 Application of 3D FEM (1 June 2014)

The distribution of the total shear stresses in the side shell and longitudinal bulkhead/inner skin bulkhead plating (net thickness) may be calculated using a 3D FEM structural analysis to check the shear strength for all the anticipated loading conditions.

FIGURE 1A
Definition of b_s and Extent for Calculating A_{ob} and A_s - Single Center Cargo Tank

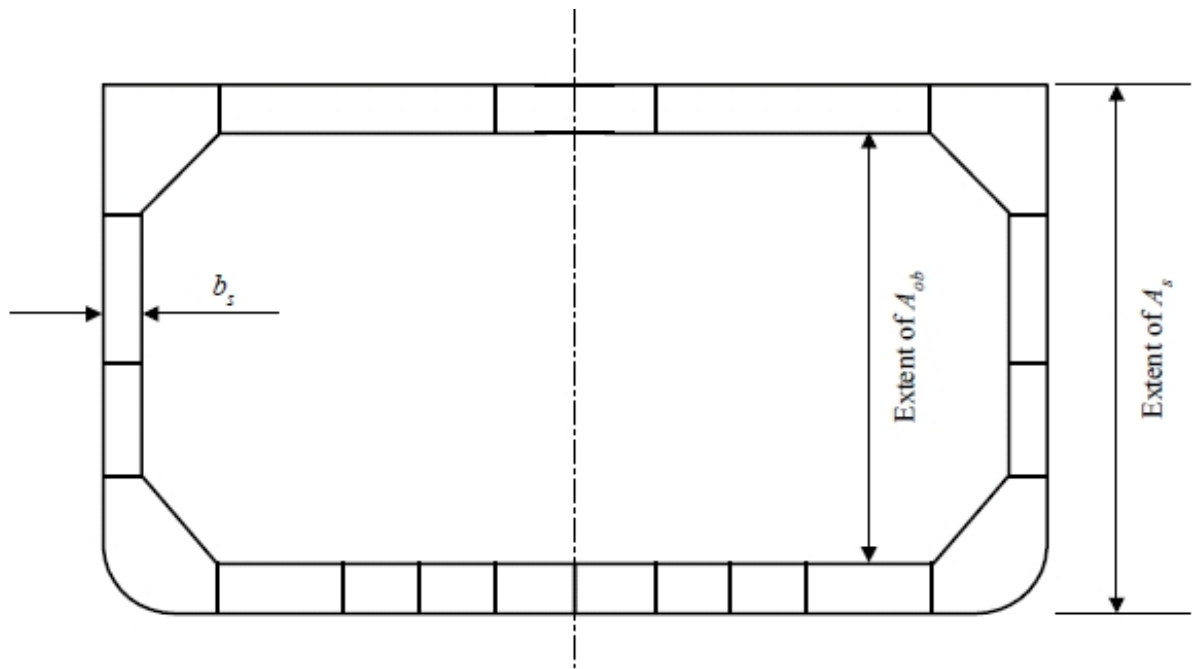

Floating Terminals with Two Longitudinal Bulkheads

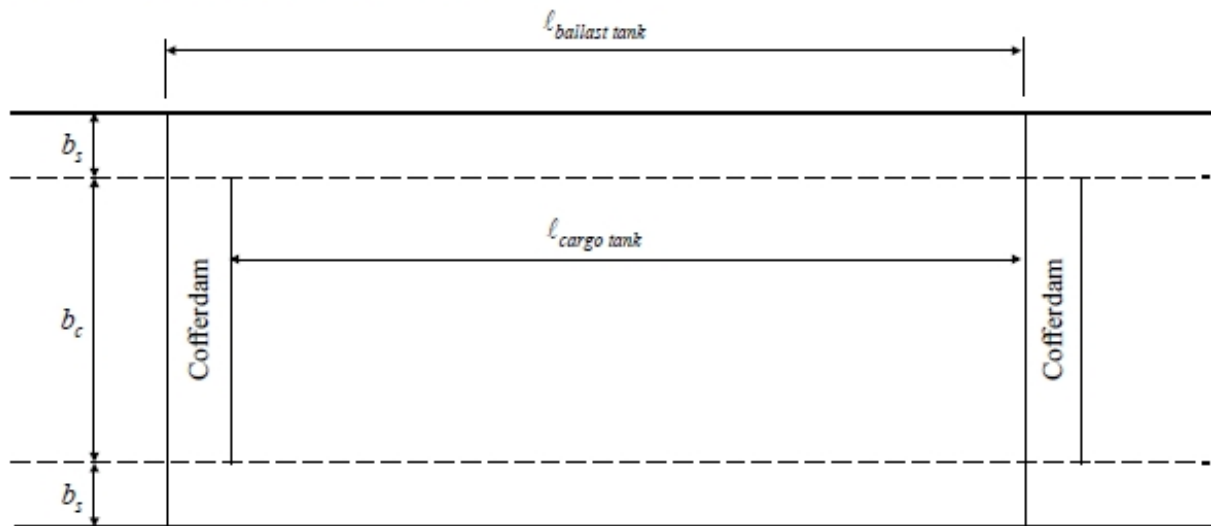
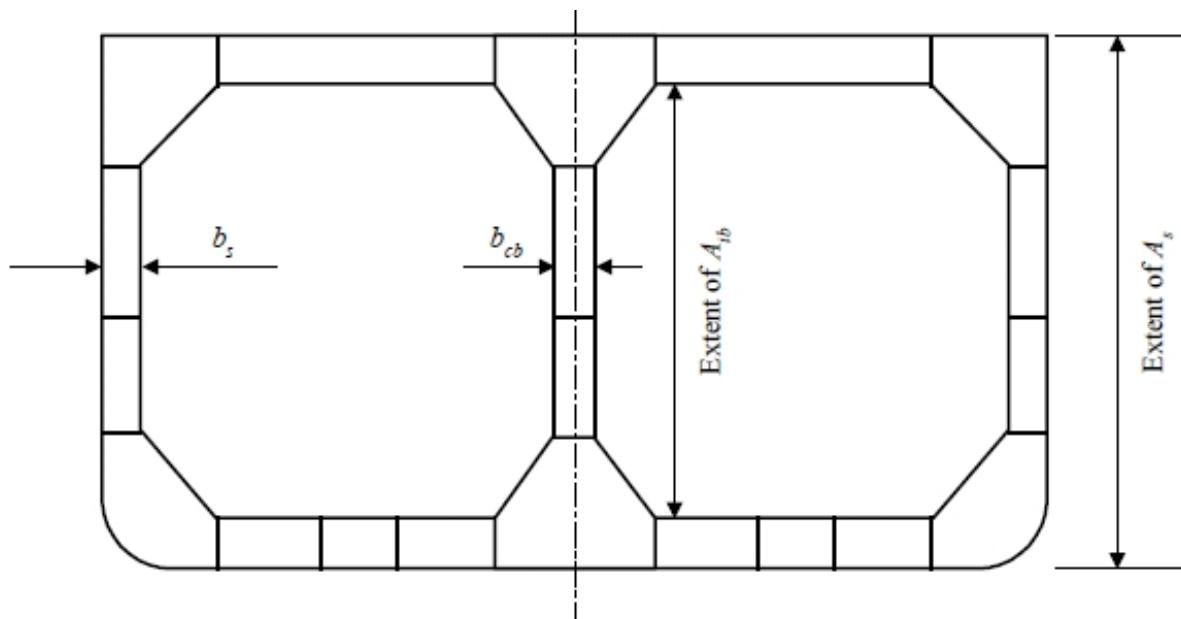
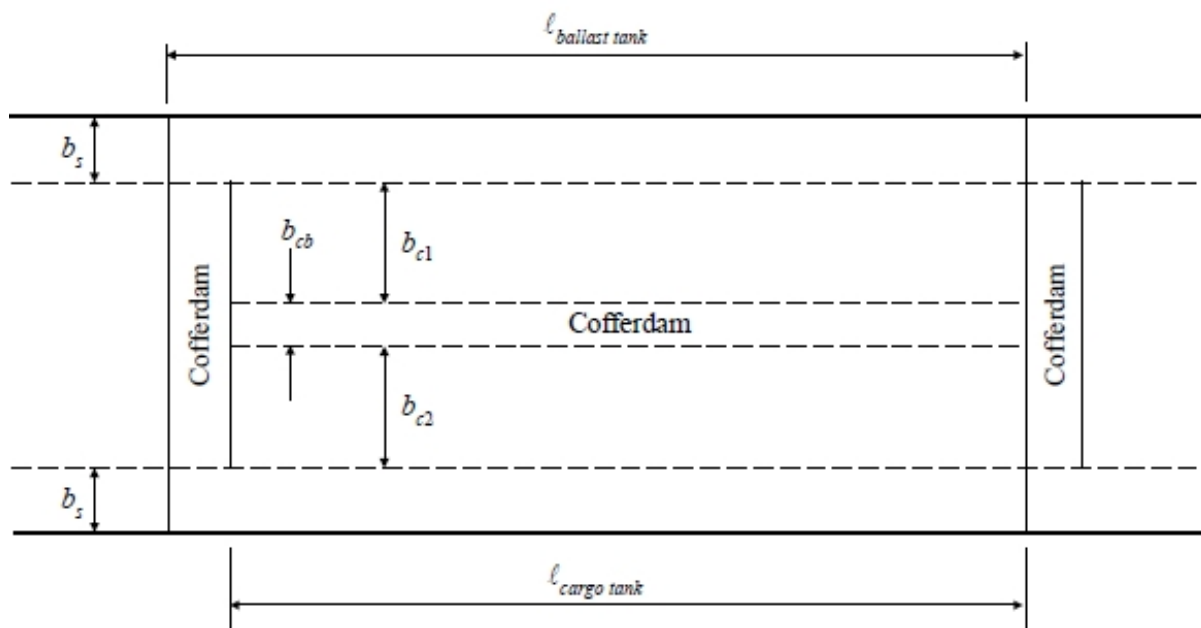

FIGURE 1B
 Definition of b_s and Extent for Calculating A_{ib} and A_s - Two Tanks Abreast



Floating Terminals with Four Longitudinal Bulkheads



7 Double Bottom Structures

7.1 General

7.1.1 Arrangement (1 September 2012)

The arrangement of double bottom girders, floors, stiffening systems and access openings are to be in compliance with Section 3-2-4 of the *Marine Vessel Rules*. In Section 3-2-4 of the *Marine Vessel Rules*, the maximum spacing of solid floors is stated as 3.66 m (12 ft). For FLGTs the

spacing of solid floors in the cargo area is not limited to 3.66 m (12 ft), provided the structure is proven to be adequate by the ISE and TSA analyses. For FLGTs with independent tanks the spacing of the solid floors must be adequate for the proper transfer of loads from the cargo tank supports. For FLGTs with membrane tanks the spacing of the solid floors is to be adequate to prevent the deflection of the plate panels on which the membrane insulation systems are installed from exceeding the maximum allowable deflection as per 3-5/5.1.1 of this Guide. Centerline and side girders are to be fitted as necessary to provide sufficient stiffness and strength for docking loads as well as those specified in Chapter 3, Section 3 of this Guide.

7.1.2 Keel Plate - Net Thickness

The net thickness of the flat plate keel is to be not less than 1.5 mm (0.06 in.) greater than the net thickness required at that location for bottom shell plating (see 3-4/7.3.1). Where the submitted docking plan (see 3-1-2/11 of the *Marine Vessel Rules*) specifies that all docking blocks be arranged away from the keel, the 1.5 mm (0.06 in.) increase in net thickness is not required.

7.1.3 Bottom Shell Plating - Definition

The term “bottom shell plating” refers to the bottom plating from the keel to the upper turn of the bilge extending over 0.4L amidships.

7.1.4 Bilge Longitudinals

Longitudinals around the bilge are to be graded in size from that required for the lowest side longitudinal to that required for the bottom longitudinals. Where longitudinals are omitted in way of the bilge, the bottom and side longitudinals are to be arranged so that the distance between the nearest longitudinal and the turn of the bilge is not more than 0.4s (s is the spacing of bottom (S_b) or side (S_s) longitudinals), as applicable (see 3-4/Figure 2).

FIGURE 2

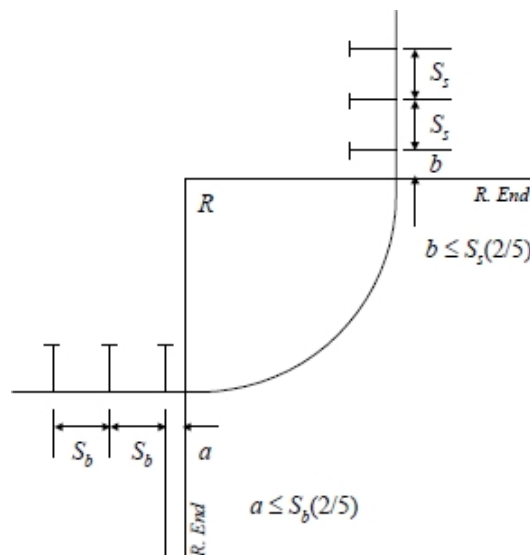

7.3 Bottom Shell and Inner Bottom Plating

The thickness of the bottom shell and inner bottom plating, over the midship 0.4L, is to satisfy the hull girder section modulus requirements in 3-2-1/3.7 of the *Marine Vessel Rules*. The buckling and ultimate strength are to be in accordance with the requirements in 3-5/5. In addition, the net thickness of the bottom shell and inner bottom plating is to be not less than given by the following:

7.3.1 Bottom Shell Plating - Net Thickness (1 June 2014)

The net thickness of the bottom shell plating, t_n , is to be not less than t_1, t_2 nor t_3 specified as follows:

$$t_1 = 0.73s(k_1p/f_1)^{1/2} \quad \text{mm(in.)}$$

$$t_2 = 0.73s(k_2p/f_2)^{1/2} \quad \text{mm(in.)}$$

$$t_3 = cs(S_m f_y/E)^{1/2*} \quad \text{mm(in.)}$$

* The net thickness, t_3 , may be determined based on S_m and f_y of the hull girder strength material required at the location under consideration.

where

s = spacing of bottom longitudinals, in mm (in.)

k_1 = 0.342

k_2 = 0.500

p = $p_a - p_{uh}$ or p_b , whichever is greater, in N/cm² (kgf/cm², lbf/in²)

p_{uh} = $0.12\gamma(h\ell_{wt}\tan\phi_e)^{1/2}$ where $\ell_{wt} \geq 0.20L$

= 0 where $\ell_{wt} \leq 0.15L$

Linear interpolation is to be used for intermediate values of ℓ_{wt} .

Where the top of the double side ballast tank does not extend to the exposed deck, is to be taken as zero.

p_a, p_b = nominal pressures, in N/cm² (kgf/cm², lbf/in²), as defined in load case “a” and “b” in 3-3/Table 3 for bottom plating, respectively

γ = specific weight of the ballast water, 1.005 N/cm²-m (0.1025 kgf/cm²-m, 0.4444 lbf/in²-ft)

h = height of double side ballast tank at vessel’s side, in m (ft)

ℓ_{wt} = length of double side ballast tank, in m (ft), measured at the top of the tank

L = scantling length of vessel, in m (ft), as defined in 3-1-1/3.1 of the *Marine Vessel Rules*

ϕ_e = effective pitch amplitude

= 0.71ϕ

ϕ = pitch amplitude as defined in 3-3/5.7.1

f_1 = permissible bending stress, in the longitudinal direction, in N/cm² (kgf/cm², lbf/in²)

= $(1 - 0.70\alpha_1 SM_{RB}/SM_B)S_m f_y \leq f_{max}$

= $(1 - 0.70\alpha_1 SM_{RB}/SM_B)S_m f_y \leq (0.40 + 0.1(190 - L)/40)S_m f_y$ for $L < 190$ m

f_{max} = $0.40S_m f_y$ within $0.4L$ amidships

= $0.55S_m f_y$ peak bulkhead to the end

Linear interpolation is to be used for the intermediate location.

- $\alpha_1 = S_{m1}f_{y1}/S_mf_y$
 $SM_{RB} =$ reference net hull girder section modulus based on the material factor of the bottom flange of the hull girder, in $\text{cm}^2\text{-m}$ ($\text{in}^2\text{-ft}$)
 $= 0.92SM$
 $SM_B =$ net design hull girder section modulus to the bottom, in $\text{cm}^2\text{-m}$ ($\text{in}^2\text{-ft}$)
 $SM =$ required hull girder section modulus in accordance with 3-4/3.5.1, taking into consideration the material factor of the bottom flange of the hull girder, in $\text{cm}^2\text{-m}$ ($\text{in}^2\text{-ft}$)
 $f_2 =$ permissible bending stress, in the transverse direction, in N/cm^2 (kgf/cm^2 , lbf/in^2)
 $= 0.80S_mf_y$ 0.4L amidships
 $= 1.00S_mf_y$ peak bulkhead to the end
 Linear interpolation is to be used for the intermediate location.
 $S_m =$ strength reduction factor for the bottom plating
 $= 1.0$ for ordinary strength steel
 $= 0.95$ for H32 strength steel
 $= 0.908$ for H36 strength steel
 $S_{m1} =$ strength reduction factor for the bottom flange of the hull girder
 $f_y =$ minimum specified yield point of the bottom plating material, in N/cm^2 (kgf/cm^2 , lbf/in^2)
 $f_{y1} =$ minimum specified yield point of the bottom flange of the hull girder, in N/cm^2 (kgf/cm^2 , lbf/in^2)
 $E =$ modulus of elasticity of the material, may be taken as $2.06 \times 10^7 \text{ N/cm}^2$ ($2.1 \times 10^6 \text{ kgf/cm}^2$, $30 \times 10^6 \text{ lbf/in}^2$) for steel
 $c = 0.7N^2 - 0.2$, not to be less than $0.4Q^{1/2}$
 $N = R_b(Q/Q_b)^{1/2}$
 $R_b = (SM_{RBH}/SM_B)^{1/2}$
 $SM_{RBH} =$ reference net hull girder section modulus for hogging bending moment based on the material factor of the bottom flange of the hull girder, in $\text{cm}^2\text{-m}$ ($\text{in}^2\text{-ft}$)
 $= 0.92SM_H$
 $SM_H =$ required hull girder section modulus in accordance with 3-2-1/3.7.1 and 3-2-1/5.5 of the *Marine Vessel Rules*, for hogging total bending moment based on the material factor of the bottom flange of the hull girder, in $\text{cm}^2\text{-m}$ ($\text{in}^2\text{-ft}$)
 $Q, Q_b =$ material conversion factor in for the bottom shell plating under consideration and the bottom flange of the hull girder, respectively
 $= 1.0$ for ordinary strength steel
 $= 0.78$ for H32 strength steel
 $= 0.72$ for H36 strength steel

* The net thickness, t_3 , may be determined based on S_m and f_y of the hull girder strength material required at the location under consideration.

In addition to the foregoing, the net thickness of the bottom shell plating, outboard of $0.3B$ from the centerline of the vessel, is to be not less than that of the lowest side shell plating required by 3-4/9.1 adjusted for the spacing of the longitudinals and the material factors.

The net thickness of the bottom shell plating in way of the pipe duct space is also to be not less than that of the bottom plating in way of the adjacent space.

7.3.2 Inner Bottom Plating - Net Thickness (1 June 2014)

The net thickness of the inner bottom plating, t_n , is to be not less than t_1, t_2, t_3 or t_4 specified as follows:

$$t_1 = 0.73s(k_1p/f_1)^{1/2} \quad \text{mm(in.)}$$

$$t_2 = 0.73sk(k_2p/f_2)^{1/2} \quad \text{mm(in.)}$$

$$t_3 = cs(S_m f_y / E)^{1/2*} \quad \text{mm(in.)}$$

$$t_4 = 0.73sk(k_2p_{gc}/f)^{1/2} \quad \text{mm(in.)}$$

Where the inner bottom plating is transversely stiffened locally, the net thickness of the inner bottom plating, t_n , is to be not less than t_5 or t_6 in lieu of t_1, t_2, t_3 and t_4 , specified as follows:

$$t_5 = 0.73s_t k(k_2p/f_2)^{1/2} \quad \text{mm(in.)}$$

$$t_6 = 0.73s_t k(k_2p_{gc}/f)^{1/2} \quad \text{mm(in.)}$$

where

s = spacing of inner bottom longitudinals, in mm (in.)

s_t = spacing of transversely stiffened bracket, in mm (in.)

k_1 = 0.342

k_2 = 0.50

k = $(3.075\alpha^{1/2} - 2.077)/(\alpha + 0.272)$ $(1 \leq \alpha \leq 2)$

= 1.0 $(\alpha > 2)$

α = aspect ratio of the panel (longer edge/shorter edge)

p = $p_a - p_{uh}$ or p_b , whichever is greater, in N/cm^2 (kgf/cm^2 , lbf/in^2)

p_a, p_b = nominal pressures, in N/cm^2 (kgf/cm^2 , lbf/in^2), as defined in load case "a" and "b" in 3-3/Table 3 for inner bottom plating, respectively

p_{uh} = defined in 3-4/7.3.1

f_1 = permissible bending stress, in the longitudinal direction, in N/cm^2 (kgf/cm^2 , lbf/in^2)

= $(1 - 0.52\alpha_1 SM_{RB}/SM_B) S_m f_y \leq f_{max}$, where SM_B/SM_{RB} is not to be taken more than 1.4

$$f_{max} = 0.57S_m f_y \quad 0.4L \text{ amidships}$$

$$= 0.65S_m f_y \quad \text{peak bulkhead to the end}$$

Linear interpolation is to be used for the intermediate location.

$$f_2 = \text{permissible bending stress, in the transverse direction, in N/cm}^2 \text{ (kgf/cm}^2 \text{, lbf/in}^2\text{)}$$

$$= 0.85S_m f_y \quad 0.4L \text{ amidships}$$

$$= 1.00S_m f_y \quad \text{peak bulkhead to the end}$$

Linear interpolation is to be used for the intermediate location.

$$f = 0.75f_y$$

$$\alpha_1 = S_{m1}f_{y1}/S_m f_y$$

$$S_m = \text{strength reduction factor obtained from 3-4/7.3.1 for the inner bottom material}$$

$$S_{m1} = \text{strength reduction factor obtained from 3-4/7.3.1 for the bottom flange material}$$

$$f_y = \text{minimum specified yield point of the inner bottom material, in N/cm}^2 \text{ (kgf/cm}^2 \text{, lbf/in}^2\text{)}$$

$$f_{y1} = \text{minimum specified yield point of the bottom flange material, in N/cm}^2 \text{ (kgf/cm}^2 \text{, lbf/in}^2\text{)}$$

$$c = 0.7N^2 - 0.2, \text{ not to be less than } 0.37Q^{1/2}$$

$$N = R_b[(Q/Q_b)(y/y_n)]^{1/2}$$

$$Q, Q_b = \text{material conversion factor for the inner bottom plating under consideration and the bottom flange of the hull girder, respectively}$$

$$= 1.0 \quad \text{for ordinary strength steel}$$

$$= 0.78 \quad \text{for H32 strength steel}$$

$$= 0.72 \quad \text{for H36 strength steel}$$

$$y = \text{vertical distance, in m (ft), measured from the inner bottom to the neutral axis of the hull girder section}$$

$$y_n = \text{vertical distance, in m (ft), measured from the bottom to the neutral axis of the hull girder section}$$

$$p_{gc} = p_o + (p_{gd})_{max} \text{ N/cm}^2 \text{ (kgf/cm}^2 \text{, lbf/in}^2\text{)}$$

$$p_o = \text{cargo tank design vapor pressure in N/cm}^2 \text{ (kgf/cm}^2 \text{, lbf/in}^2\text{), as defined in 3-1/3.11}$$

$$p_{gd} = \alpha_\beta Z_\beta k_3 \rho 10^{-4} \text{ N/cm}^2 \text{ (kgf/cm}^2 \text{, lbf/in}^2\text{)}$$

$$\alpha_\beta = \text{dimensionless acceleration, see 3-3/5.9.2}$$

$$Z_\beta = \text{largest cargo tank liquid head in m (ft) above the point on the inner bottom under consideration, see 3-3/5.9.2}$$

$$k_3 = 9.81(1.0, 69.44)$$

$$\rho = \text{maximum cargo density, in N/m}^3 \text{ (kgf/m}^3 \text{, lbf/ft}^3\text{), at the design temperature, but } \rho \text{ is not to be taken less than } 4900 \text{ N/m}^3 \text{ (500 kgf/m}^3 \text{, 31.214 lbf/ft}^3\text{)}$$

$$SM_{RB} = \text{reference net hull girder section modulus based on the material factor of the bottom flange of the hull girder, in cm}^2\text{-m (in}^2\text{-ft)}$$

	=	$0.92SM$
SM_B	=	net design hull girder section modulus to the bottom, in $\text{cm}^2\text{-m}$ ($\text{in}^2\text{-ft}$)
SM	=	required hull girder section modulus in accordance with 3-4/3.5.1, taking into consideration the material factor of the bottom flange of the hull girder, in $\text{cm}^2\text{-m}$ ($\text{in}^2\text{-ft}$)
R_b	=	$(SM_{RBH}/SM_B)^{1/2}$
SM_{RBH}	=	reference net hull girder section modulus for hogging bending moment based on the material factor of the bottom flange of the hull girder, in $\text{cm}^2\text{-m}$ ($\text{in}^2\text{-ft}$)
	=	$0.92SM_H$
SM_H	=	required hull girder section modulus in accordance with 3-2-1/3.7.1 and 3-2-1/5.5 of the <i>Marine Vessel Rules</i> , for hogging total bending moment based on the material factor of the bottom flange of the hull girder, in $\text{cm}^2\text{-m}$ ($\text{in}^2\text{-ft}$)
E	=	modulus of elasticity of the material, may be taken as $2.06 \times 10^7 \text{ N/cm}^2$ ($2.1 \times 10^6 \text{ kgf/cm}^2$, $30 \times 10^6 \text{ lbf/in}^2$) for steel

* The net thickness, t_3 , may be determined based on S_m and f_y of the hull girder strength material required at the location under consideration.

In addition to the foregoing, the net thickness of the inner bottom plating outboard of $0.3B$ from the centerline, is also to be not less than t_1 , t_2 nor t_5 required by 3-4/13.1 for the lowest strake on the inner skin bulkhead, adjusted for the spacing of the longitudinals and the material factor.

For transversely stiffened inner bottom plating, buckling in transverse direction is to be checked in total strength assessment in lieu of t_3 requirement.

The net thickness of the inner bottom plating in way of a pipe duct space is not to be less than that of the inner bottom plating.

7.5 Bottom, Bilge and Inner Bottom Longitudinals

7.5.1 Bottom Longitudinals - Net Section Modulus (1 June 2014)

The net section modulus of each bottom longitudinal, in association with the effective plating to which it is attached, is to be not less than obtained from the following equation:

$$SM = M/f_b \quad \text{cm}^3(\text{in}^3)$$

where

M	=	$1000ps\ell^2/k$ N-cm (kgf-cm, lbf-in.)
k	=	12 (12, 83.33)
s	=	spacing of longitudinals, in mm (in.)
ℓ	=	span of the longitudinal between effective supports, as shown in 3-4/Figure 3, in m (ft)
p	=	$p_a - p_{uh}$ or p_b , whichever is greater, in N/cm^2 (kgf/cm^2 , lbf/in^2) as specified in 3-4/7.3.1
f_b	=	permissible bending stresses, in N/cm^2 (kgf/cm^2 , lbf/in^2)
	=	$(1.0 - 0.65\alpha_1 SM_{RB}/SM_B) S_m f_y \leq f_{max}$

$$f_{max} = 0.55S_m f_y \quad 0.4L \text{ amidships}$$

$$= 0.70S_m f_y \quad \text{peak bulkhead to the end}$$

Linear interpolation is to be used for the intermediate location.

$$\alpha_1 = S_{m1} f_{y1} / S_m f_y$$

S_m = strength reduction factor, as defined in 3-4/7.3.1, for the material of longitudinals considered

S_{m1} = strength reduction factor, as defined in 3-4/7.3.1, for the bottom flange material

f_y = minimum specified yield point for the material of the longitudinals considered, in N/cm² (kgf/cm², lbf/in²)

f_{y1} = minimum specified yield point of the bottom flange material, in N/cm² (kgf/cm², lbf/in²)

SM_{RB} = reference net hull girder section modulus based on the material factor of the bottom flange of the hull girder, in cm²-m (in²-ft)

$$= 0.92SM$$

SM_B = net design hull girder section modulus to the bottom, in cm²-m (in²-ft)

SM = required hull girder section modulus in accordance with 3-4/3.5.1, taking into consideration the material factor of the bottom flange of the hull girder, in cm²-m (in²-ft)

In addition, the net section modulus of bottom longitudinals, outboard of $0.3B$ from the centerline of the vessel, is to be not less than that of the lowest side longitudinal required by 3-4/9.5, adjusted for the span and spacing of the longitudinals and the material factors.

In determining compliance with the foregoing, an effective breadth, b_e , of attached plating is to be used in calculation of the section modulus of the design longitudinal. b_e is to be obtained from line b) of 3-4/Figure 4.

7.5.2 Bilge Longitudinals - Net Section Modulus

Longitudinals around the bilge, if fitted, are to be graded in size from that required for the lowest side longitudinal to that required for the bottom longitudinals.

7.5.3 Inner Bottom Longitudinals - Net Section Modulus (1 June 2014)

The net section modulus of each inner bottom longitudinal, in association with the effective plating to which it is attached, is to be not less than is required to satisfy each of the following equations:

$$SM = M_1 / f_{b1} \quad \text{cm}^3(\text{in}^3)$$

$$SM = c_{gc} K M_2 / f_{b2} \quad \text{cm}^3(\text{in}^3)$$

where

$$M_1 = 1000ps\ell^2/k \text{ N-cm (kgf-cm, lbf-in.)}$$

$$p = p_a - p_{uh} \text{ or } p_b, \text{ whichever is greater, in N/cm}^2 \text{ (kgf/cm}^2 \text{, lbf/in}^2 \text{), as specified in 3-4/7.3.2}$$

$$s = \text{spacing of longitudinals, in mm (in.)}$$

- ℓ = span of the longitudinal between effective supports, as shown in 3-4/Figure 3, in m (ft)
- k = 12 (12, 83.33)
- f_{b1} = permissible bending stresses, in N/cm² (kgf/cm², lbf/in²)
 = $(1.0 - 0.50\alpha_1 SM_{RB}/SM_B) S_m f_y \leq f_{max}$
- f_{max} = 0.65 $S_m f_y$ 0.4L amidships
 = 0.75 $S_m f_y$ peak bulkhead to the end

Linear interpolation is to be used for the intermediate location.

- α_1 = $S_{m1} f_{y1} / S_m f_y$
- SM_{RB} = reference net hull girder section modulus based on the material factor of the bottom flange of the hull girder, in cm²-m (in²-ft)
 = 0.92 SM
- SM_B = net design hull girder section modulus to the bottom, in cm²-m (in²-ft)
- SM = required hull girder section modulus in accordance with 3-4/3.5.1, taking into consideration the material factor of the bottom flange of the hull girder, in cm²-m (in²-ft)
- S_m = strength reduction factor, as defined in 3-4/7.3.1, for the material of longitudinals considered.
- S_{m1} = strength reduction factor, as defined in 3-4/7.3.1, for the bottom flange material.
- f_y = minimum specified yield point for the material of the longitudinals considered, in N/cm² (kgf/cm², lbf/in²)
- f_{y1} = minimum specified yield point of the bottom flange material, in N/cm² (kgf/cm², lbf/in²)
- c_{gc} = 0.89 for longitudinals in tanks
 = 0.93 for longitudinals in voids
- K = 0.9
- M_2 = $1000 p_{gc} s \ell^2 / k$ N-cm (kgf-cm, lbf-in.)
- p_{gc} = pressure, in N/cm² (kgf/cm², lbf/in²), as obtained from 3-4/7.3.2
- f_{b2} = permissible bending stresses, in N/cm² (kgf/cm², lbf/in²)
 = $S_{gc} f_y$
- S_{gc} = 0.64 for ordinary strength steel
 = 0.53 for H32 strength steel
 = 0.52 for H36 strength steel

In addition, the net section modulus of the inner bottom longitudinals located outboard of 0.3B from the centerline, is also to be not less than required by 3-4/13.5 for the lowest inner skin bulkhead longitudinal, adjusted for the span and spacing of the longitudinals and material factors.

In determining compliance with the foregoing, an effective breadth, b_e , of attached plating is to be used in calculation of the section modulus of the design longitudinal. b_e is to be obtained from line b) of 3-4/Figure 4.

7.7 Double Bottom Girders and Floors (2018)

The minimum scantlings for double bottom girders and floors are to be determined in accordance with 3-4/7.7.2, 3-4/7.7.3, 3-4/7.7.4 and 3-4/7.7.5 as follows. The minimum scantlings of watertight double bottom girders under longitudinal bulkhead are also not to be less than the longitudinal bulkhead scantlings.

For bottom girders and floors with partial girders in way of transverse/cofferdam bulkheads, the minimum scantlings are alternatively determined from a grillage analysis or finite element analysis.

7.7.1 Double Bottom Depth

The depth of the double bottom d_{DB} at centerline is not to be less than obtained by the following equation:

$$d_{DB} = 32b_{DB} \times 10^{-3} + c\sqrt{d} \text{ m (ft)} \quad \text{for } L \leq 427 \text{ m (1400 ft)}$$

where

b_{DB} = unsupported width of the double bottom structure under consideration, in m (ft), as shown in 3-4/Figure 5

c = 0.19 (0.344)

d = molded draft of vessel, in m (ft)

The depth of the double bottom d_{DB} is to be not less than $B/15$ or 2.0 m (6 ft - 6 3/4in.), whichever is lesser. B is the breadth of vessel, in m (ft), as defined in 3-1-1/5 of the *Marine Vessel Rules*.

7.7.2 Double Bottom Centerline Girder - Net Thickness (2018)

The net thickness of the double bottom centerline girder amidships is not to be less than t_1 , t_2 nor t_3 as defined below:

$$\begin{aligned} t_1 &= (4.5\alpha_{DB}L \times 10^{-2} + 4.5) \text{ mm} && \text{within } 0.75L \text{ amidships} \\ &= 0.8(4.5\alpha_{DB}L \times 10^{-2} + 4.5) \text{ mm} && \text{others} \\ &\text{but need not be greater than } (4.5L \times 10^{-2} + 4.5)R \text{ mm} \\ &= (5.4\alpha_{DB}L \times 10^{-4} + 0.177) \text{ in.} && \text{within } 0.75L \text{ amidships} \\ &= 0.8(5.4\alpha_{DB}L \times 10^{-4} + 0.177) \text{ in.} && \text{others} \\ &\text{but need not be greater than } (5.4L \times 10^{-4} + 0.177)R \text{ in.} \\ t_2 &= F_1/(k_1d_b f_s) \text{ mm (in.)} \\ t_3 &= cs(S_m f_y/E)^{1/2} \text{ mm (in.)} \end{aligned}$$

where

α_{DB}	=	$1.45d_{DB}/D_b$ but α_{DB} is not to be taken less than 0.7 nor need be greater than 1.0
d_{DB}	=	depth of double bottom, in m (ft), as obtained from the equation in 3-4/7.7.1
D_b	=	depth of double bottom centerline girder under consideration at vessel's centerline, in m (ft)
d_b	=	actual depth of double bottom centerline girder under consideration at vessel's centerline, in m (ft)
L	=	scantling length of vessel, in m (ft), as defined in 3-1-1/3.1 of the <i>Marine Vessel Rules</i>
R	=	1.0 for ordinary strength steel $f_{ym}/S_m f_{yh}$ for higher strength material
f_{ym}	=	specified minimum yield point for ordinary strength steel, in N/cm ² (kgf/cm ² , lbf/in ²)
f_{yh}	=	specified minimum yield point for higher tensile steel, in N/cm ² (kgf/cm ² , lbf/in ²)
S_m	=	strength reduction factor = 1.0 for ordinary strength steel = 0.95 for H32 strength steel = 0.908 for H36 strength steel
k_1	=	10.0 (10.0, 12.0)
F_1	=	approximate maximum shear force in the center girder, as obtained from the equation given below (see also 3-4/1.3). Alternatively, F_1 may be determined from finite element analyses, as specified in 3-5/9 with the combined load cases in 3-5/9.7. However, F_1 is not to be taken less than 85% of that determined from the equation below, with the exception of the double bottom provided with partial girders or floors: = $1000k_2\alpha_1\gamma n_1 n_2 p \ell_s s_1$ N (kgf, lbf) for $\lambda \leq 1.5$ = $414k_2\gamma n_1 n_2 p b_{DB} s_1$ N (kgf, lbf) for $\lambda > 1.5$
k_2	=	1.0 (1.0, 2.24)
α_1	=	$0.606 - 0.22\lambda$
λ	=	ℓ_s/b_{DB}
γ	=	$3x/\ell_s - 0.5$ but not less than 0.5
n_1	=	$0.0374(s_1/s_f)^2 - 0.326(s_1/s_f) + 1.289$
n_2	=	$1.3 - (s_f/12)$ for SI or MKS Units $1.3 - (s_f/39.37)$ for U.S. Units
ℓ_s	=	unsupported length of the double bottom structures under consideration, in m (ft), as shown in 3-4/Figure 5
b_{DB}	=	unsupported width of the double bottom structure under consideration, in m (ft), as shown in 3-4/Figure 5
s_1	=	sum of one-half of girder spacings on both sides of the center girder, in m (ft)
s_f	=	average spacing of floors, in m (ft)

- x = longitudinal distance from the mid-span of unsupported length(ℓ_s) of the double bottom to the location of the girder under consideration, in m (ft).
- p = nominal pressure, in kN/m² (tf/m², Ltf/ft²), as specified in 3-3/Table 3.
- f_s = permissible shear stresses, in N/cm² (kgf/cm², lbf/in²)
= $0.45S_m f_y$
- f_y = minimum specified yield point of the material, in N/cm² (kgf/cm², lbf/in²)
- c = $0.7N^2 - 0.2$, not to be less than $0.4Q^{1/2}$ but need not be greater than $0.45(Q/Q_b)^{1/2}$
- N = $R_b[(Q/Q_b) (y/y_n)]^{1/2}$
- Q, Q_b = material conversion factor for the bottom girder and the bottom flange of the hull girder, respectively.
= 1.0 for ordinary strength steel
= 0.78 for H32 strength steel
= 0.72 for H36 strength steel
- y = vertical distance, in m (ft), measured from the lower edge of the bottom girder plating to the neutral axis of the hull girder section
- y_n = vertical distance, in m (ft), measured from the bottom to the neutral axis of the section
- s = spacing of longitudinal stiffeners on the girder, in mm (in.)
- R = 1.0 for ordinary mild steel
= $f_{ym}/S_m f_{yh}$ for higher strength material
- f_{ym} = specified minimum yield point for ordinary strength steel, in N/cm² (kgf/cm², lbf/in²)
- f_{yh} = specified minimum yield point for higher tensile steel, in N/cm² (kgf/cm², lbf/in²)
- L = scantling length of vessel, in m (ft), as defined in 3-1-1/3.1 of the *Marine Vessel Rules*
- E = modulus of elasticity of the material, may be taken as 2.06×10^7 N/cm² (2.1×10^6 kgf/cm², 30×10^6 lbf/in²) for steel
- R_b = $(SM_{RBH}/SM_B)^{1/2}$
- SM_{RBH} = reference net hull girder section modulus for hogging bending moment based on the material factor of the bottom flange of the hull girder, in cm²-m (in²-ft)
= $0.92SM_H$
- SM_H = required hull girder section modulus in accordance with 3-2-1/3.7.1 and 3-2-1/5.5 of the *Marine Vessel Rules*, for hogging total bending moment based on the material factor of the bottom flange of the hull girder, in cm²-m (in²-ft)

In addition to the above requirement, the net thickness of the center girder is to be not less than t_4 as specified below:

$$t_4 = F_{1gc} / (k_1 d_b f_{gc}) \quad \text{mm(in.)}$$

where

$$F_{1gc} = \text{hear force in the center girder, as obtained from finite element analyses, as specified in 3-5/9 with the additional IGC load cases in 3-5/9.7}$$

$$f_{gc} = \text{permissible shear stresses, in N/cm}^2 \text{ (kgf/cm}^2 \text{, lbf/in}^2\text{)}$$

$$= 0.5f_y$$

All other parameters are also defined as above.

The net thickness of the centerline girder under the cofferdam bulkhead space is not to be less than t_1, t_2, t_3 nor t_4 as required at $x = \ell_s/2$.

7.7.3 Double Bottom Side Girder - Net Thickness (2018)

The net thickness of the double bottom side girders is to be not less than t_1, t_2 nor t_3 as defined below:

$$t_1 = (2.6\alpha_{DB}L \times 10^{-2} + 4.5) \text{ mm} \quad \text{within } 0.75L \text{ amidships}$$

$$= 0.8(2.6\alpha_{DB}L \times 10^{-2} + 4.5) \text{ mm} \quad \text{others}$$

but need not be greater than $(2.6L \times 10^{-2} + 4.5)R$ mm

$$= (3.1\alpha_{DB}L \times 10^{-4} + 0.177) \text{ in.} \quad \text{within } 0.75L \text{ amidships}$$

$$= 0.8(3.1\alpha_{DB}L \times 10^{-4} + 0.177) \text{ in.} \quad \text{others}$$

but need not be greater than $(3.1L \times 10^{-4} + 0.177)R$ in.

t_1 is not to be less than the thickness given in 3-4/Table 1

$$t_2 = F_2 / (k_1 d_{bg} f_s) \text{ mm (in.)}$$

$$t_3 = c_s (S_m f_y / E)^{1/2} \text{ mm (in.)}$$

where

F_2 = approximate maximum shear force in the side girders under consideration, as obtained from the equation given below (see also 3-4/1.3). Alternatively, F_2 may be determined from finite element analyses, as specified in 3-5/9 with the combined load cases in 3-5/9.7. However, F_2 is not to be taken less than 85% of that determined from the equation below, with the exception of the double bottom provided with partial girders or floors:

$$F_2 = 1000k_2\alpha_2\beta_1\gamma n_3 n_4 p \ell_s s_2 \text{ N (kgf, lbf)} \quad \text{for } \lambda > 1.5$$

$$= 314k_2\beta_1\gamma n_3 n_4 p b_{DB} s_2 \text{ N (kgf, lbf)} \quad \text{for } \lambda > 1.5$$

$$\alpha_2 = 0.49 - 0.187\lambda$$

$$\beta_1 = 1.25 - 5(z_1/b_{DB})^2 \quad \text{for one tank abreast}$$

$$= 1.0 \quad \text{for two tanks abreast}$$

$$n_3 = 1.072 - 0.0715(s_2/s_f)$$

- $n_4 = 1.2 - (s_f/18)$ for SI or MKS Units
 $= 1.2 - (s_f/59.1)$ for U.S. Units
 d_{bg} = actual depth of double bottom girder under consideration, in m (ft)
 s_2 = sum of one-half of girder spacing on both sides of the side girders, in m (ft)
 z_1 = transverse distance from the centerline to the location of the double bottom to the girder under consideration, in m (ft)
 $c = 0.7N^2 - 0.2$, not to be less than $0.4Q^{1/2}$, but need not be greater than $0.45(Q/Q_b)^{1/2}$
 $N = R_b[(Q/Q_b)(y/y_n)]^{1/2}$
 Q, Q_b = material conversion factor in for the bottom girder and the bottom flange of the hull girder, respectively.
 $= 1.0$ for ordinary strength steel
 $= 0.78$ for H32 strength steel
 $= 0.72$ for H36 strength steel
 y = vertical distance, in m (ft), measured from the lower edge of the bottom girder plating to the neutral axis of the hull girder section
 y_n = vertical distance, in m (ft), measured from the bottom to the neutral axis of the section
 s = spacing of longitudinal stiffeners on the girder, in mm (in.)

$\gamma, k_1, k_2, \alpha_{DB}, \ell_s, b_{DB}, \lambda, s_f, p, d_b, f_s, L, R, S_m$ and f_y are as defined in 3-4/7.7.2 above.

In addition to the above requirement, the net thickness of the side girder is to be not less than t_4 as specified below:

$$t_4 = F_{2gc} / (k_1 d_{bg} f_{gc}) \quad \text{mm(in.)}$$

where

- F_{2gc} = shear force in the side girder, as obtained from finite element analyses, as specified in 3-5/9 with the additional IGC load cases in 3-5/9.7
 f_{gc} = permissible shear stresses, in N/cm² (kgf/cm², lbf/in²)
 $= 0.5f_y$

All other parameters are also defined as above.

The net thickness of the side girder under the cofferdam bulkhead space is not to be less than t_1, t_2, t_3 nor t_4 as required at $x = \ell_s/2$.

The net thickness of the double bottom side girders under the longitudinal bulkheads is to be not less than t_1 and t_3 as required above.

7.7.4 Double Bottom Floors - Net Thickness (2018)

The net thickness of double bottom floors is to be not less than t_1 nor t_2 , as specified below:

$$\begin{aligned} t_1 &= (2.6\alpha_{DB}L \times 10^{-2} + 4.5) \text{ mm} && \text{within } 0.75L \text{ amidships} \\ &= 0.8(2.6\alpha_{DB}L \times 10^{-2} + 4.5) \text{ mm} && \text{others} \\ &\text{but need not be greater than } (2.6L \times 10^{-2} + 4.5)R \text{ mm} \\ &= (3.1\alpha_{DB}L \times 10^{-4} + 0.177) \text{ in.} && \text{within } 0.75L \text{ amidships} \\ &= 0.8(3.1\alpha_{DB}L \times 10^{-4} + 0.177) \text{ in.} && \text{others} \end{aligned}$$

but need not be greater than $(3.1L \times 10^{-4} + 0.177)R$ in.

t_1 is not to be less than the thickness given in 3-4/Table 1

$$t_2 = F_3 / (k_1 d_{bf} f_s) \text{ mm (in.)}$$

where

F_3 = approximate maximum shear force in the floors under consideration, as obtained from the equation given below (see also 3-4/1.3). Alternatively, F_3 may be determined from finite element analyses, as specified in 3-5/9 with the combined load cases in 3-5/9.7. However, F_3 is not to be taken less than 85% of that determined from the equation below, with the exception of the double bottom provided with partial girders or floors:

$$= 950 k_2 \alpha_3 \beta_2 p b_{DB} s_3 \text{ N (kgf, lbf)}$$

d_{bf} = actual depth of double bottom floor under consideration, in m (ft)

$$\alpha_3 = 0.5\eta(0.66 - 0.08\eta)$$

$$\beta_2 = 2z_2 / b_{DB} \geq 0.4$$

$$\eta = (\ell_s / b_{DB})(s_g / s_f)^{1/4}$$

s_3 = sum of one-half of floor spacing on both sides of the floor under consideration, in m (ft)

s_g = average spacing of girders, in m (ft)

z_2 = transverse distance from the centerline of the unsupported width b_{DB} of the double bottom to the location of the floor under consideration, in m (ft)

$$f_s = 0.45 S_m f_y \text{ in N/cm}^2 \text{ (kgf/cm}^2, \text{ lbf/in}^2)$$

$\ell_s, k_1, k_2, \alpha_{DB}, b_{DB}, s_f, R, p, d_b, L, S_m$ and f_y are as defined in 3-4/7.7.2 above.

In addition to the above requirement, the net thickness of the floor is to be not less than t_3 as specified below:

$$t_3 = F_{3gc} / (k_1 d_{bf} f_{gc}) \text{ mm(in.)}$$

where

$$F_{3gc} = \text{shear force in the floor, as obtained from finite element analyses, as specified in 3-5/9 with the additional IGC load cases in 3-5/9.7}$$

$$f_{gc} = \text{permissible shear stresses, in N/cm}^2 \text{ (kgf/cm}^2 \text{, lbf/in}^2\text{)}$$

$$= 0.5f_y$$

All other parameters are also defined as above.

The thickness and material properties of double bottom floors in line with the cofferdam bulkheads are to be at least 75% of those provided for the lowest strake of the cofferdam bulkhead plating.

7.7.5 Double Bottom Tank Boundary Girders - Net Thickness

The net thickness of double bottom girders forming boundaries of deep tanks, in addition to complying with 3-4/7.7.2 or 3-4/7.7.3 as appropriate, is to be not less than t_1 nor t_2 as specified below:

$$t_1 = 0.73s(k_1p/f_1)^{1/2} \quad \text{mm(in.)}$$

$$t_2 = 0.73s(k_2p/f_2)^{1/2} \quad \text{mm(in.)}$$

where

$$s = \text{spacing of longitudinal or vertical stiffeners on the girder, in mm (in.)}$$

$$k_1 = 0.342 \text{ for longitudinally stiffened plate}$$

$$= 0.50k^2 \text{ for vertically stiffened plate}$$

$$k_2 = 0.50k^2$$

$$k = (3.075\alpha^{1/2} - 2.077)/(\alpha + 0.272) \quad \text{where } 1 \leq \alpha < 2$$

$$= 1.0 \quad \text{where } \alpha \geq 2$$

$$\alpha = \text{aspect ratio of plate panel (longer edge/shorter edge)}$$

$$p = p_n - p_{uo}$$

$$p_n = \text{nominal pressure, in N/cm}^2 \text{ (kgf/cm}^2 \text{, lbf/in}^2\text{), at lower edge of each plate as specified in 3-3/Table 3 for watertight double bottom girder}$$

$$p_{uo} = 0.0 \text{ where the watertight double bottom girder does not form the boundary of a double side ballast tank}$$

$$= \text{where the watertight double bottom girder forms the boundary of a double side ballast tank that extends to the exposed deck:}$$

$$= 0.24\gamma(h\ell_{wt}b_{wt}\tan\phi_e\tan\theta_e)^{1/3} \quad \text{where } \ell_{wt} \geq 0.20L$$

$$= 0.0 \quad \text{where } \ell_{wt} \leq 0.15L$$

linear interpolation may be used to determine p_{uo} where $0.15L < \ell_{wt} < 0.20L$

$$\gamma = \text{specific weight of the ballast water, 1.005 N/cm}^2\text{-m (0.1025 kgf/cm}^2\text{-m, 0.4444 lbf/in}^2\text{-ft)}$$

$$h = \text{height of double side ballast tank at vessel's side, in m (ft)}$$

$$\ell_{wt} = \text{length of double side ballast tank in m (ft) measured at the top of the tank}$$

b_{wt}	=	breadth of double side ballast tank in m (ft) measured at the top of the tank
ϕ_e	=	effective pitch amplitude as defined in 3-3/5.7.2 with $C_\phi = 0.7$
θ_e	=	effective roll amplitude as defined in 3-3/5.7.2 with $C_\theta = 0.7$
f_1	=	permissible bending stress, in the longitudinal direction, in N/cm ² (kgf/cm ² , lbf/in ²)
	=	$[1 - 0.36(z_1/B) - 0.53\alpha_1(SM_{RB}/SM_B)(y/y_n)]S_m f_y \leq 0.65S_m f_y$
f_2	=	permissible bending stress, in vertical direction, in N/cm ² (kgf/cm ² , lbf/in ²)
	=	$0.90S_m f_y$
α_1	=	$S_{m1} f_{y1} / S_m f_y$
S_m	=	strength reduction factor for the girder material
	=	1.0 for ordinary strength steel
	=	0.95 for HT32 strength steel
	=	0.908 for HT36 strength steel
S_{m1}	=	strength reduction factor for the hull girder bottom flange material of hull girder
f_y	=	minimum specified yield point of the girder material, in N/cm ² (kgf/cm ² , lbf/in ²)
f_{y1}	=	minimum specified yield point of the hull girder bottom flange material, in N/cm ² (kgf/cm ² , lbf/in ²)
y	=	vertical distance, in m (ft), measured from the neutral axis of the hull girder transverse section to the lower edge of each plate where the plating is longitudinally stiffened
	=	vertical distance, in m (ft), measured from the neutral axis of the hull girder transverse section to the mid-depth of the double bottom height where the plating is vertically stiffened
y_n	=	vertical distance, in m (ft), measured from the bottom to the neutral axis of the hull girder section
B	=	vessel breadth, in m (ft), as defined in 3-1-1/5 of the <i>Marine Vessel Rules</i>
SM_{RB}	=	reference net hull girder section modulus based on the material factor of the bottom flange of the hull girder, in cm ² -m (in ² -ft)
	=	$0.92SM$
SM_B	=	net design hull girder section modulus to the bottom, in cm ² -m (in ² -ft)
SM	=	required hull girder section modulus in accordance with 3-4/3.5.1, taking into consideration the material factor of the bottom flange of the hull girder, in cm ² -m (in ² -ft)
z_1	=	transverse distance from the centerline of the unsupported width b_{DB} of the double bottom to the girder under consideration, in m (ft)
b_{DB}	=	unsupported width of the double bottom structure under consideration, in m (ft), as shown in 3-4/Figure 5

7.7.6 Double Bottom Tight Girders - Longitudinal Stiffeners - Net Section Modulus

The net section modulus of each longitudinal on tight double bottom girders, in association with the effective plating to which it is attached, is to be not less than obtained from the following equation:

$$SM = M / f_b \quad \text{cm}^3(\text{in}^3)$$

where

$$M = 1000ps\ell^2/k \text{ N-cm (kgf-cm, lbf-in.)}$$

$$k = 12 (12, 83.33)$$

$$s = \text{spacing of longitudinals, in mm (in.)}$$

$$\ell = \text{span of the longitudinal between effective supports, as shown in 3-4/Figure 3, in m (ft)}$$

$$p = \text{nominal pressure, in kN/m}^2 \text{ (tf/m}^2, \text{ Ltf/ft}^2\text{), as specified in 3-3/Table 3.}$$

$$f_b = \text{permissible bending stresses, in N/cm}^2 \text{ (kgf/cm}^2, \text{ lbf/in}^2\text{)}$$

$$= 1.2[1 - 0.32z/B - 0.53\alpha_1(SM_{RB}/SM_B)(y/y_n)]S_m f_y \leq 0.8S_m f_y$$

$$z = \text{horizontal distance, in m (ft), from the centerline to the girder on which the stiffener is fitted}$$

$$y = \text{vertical distance, in m (ft), measured from the longitudinal to the neutral axis of the hull girder section}$$

$$y_n = \text{vertical distance, in m (ft), measured from the base line to the neutral axis of the hull girder section}$$

SM_{RB} and SM_B are as defined in 3-4/7.3.1.

All other parameters are defined in 3-4/7.5.1

7.9 Structure in Pipe Duct Space

7.9.1 Transverses on Bottom Shell

Bottom transverses in a pipe duct space are to have a section modulus, SM and a cross sectional area, A_s , not less than obtained from the following equations:

$$SM = M / f_b \quad \text{cm}^3(\text{in}^3)$$

$$A_s = F / f_s \quad \text{cm}^2(\text{in}^2)$$

where

$$M = ps\ell^2 10^5 / k_1 \text{ N-cm (kgf-cm, lbf-in.)}$$

$$p = \text{nominal pressure for the bottom transverse, in kN/m}^2 \text{ (tf/m}^2, \text{ Ltf/ft}^2\text{), as specified in 3-3/Table 3.}$$

$$s = \text{spacing of the transverse, in m (ft)}$$

$$\ell = \text{span of the transverse as defined in 3-4/Figure 7, in m (ft)}$$

$$k_1 = 10 (10, 37.2)$$

$$\begin{aligned}
 f_b &= \text{permissible bending stress, in N/cm}^2 \text{ (kgf/cm}^2 \text{, lbf/in}^2\text{)} \\
 &= 0.7 S_m f_y \\
 S_m &= \text{strength reduction factor for the transverses, as defined in 3-4/7.3.1} \\
 f_y &= \text{minimum specified yield point for the transverses, in N/cm}^2 \text{ (kgf/cm}^2 \text{, lbf/in}^2\text{)} \\
 F &= k_2 600 p s \ell \text{ N (kgf, lbf)} \\
 k_2 &= 1.0 \text{ (1.0, 2.24)} \\
 f_s &= \text{permissible shear stress, in N/cm}^2 \text{ (kgf/cm}^2 \text{, lbf/in}^2\text{)} \\
 &= 0.4 S_m f_y
 \end{aligned}$$

The net thickness of the web plate of the transverse is not to be less than t_1 obtained in 3-4/7.7.4, adjusted for the material of the web plate.

7.9.2 Transverses on Inner Bottom Plating

Inner bottom transverses in a pipe duct space are to have a section modulus, SM and a cross sectional area, A_s , not less than obtained from the following equations:

$$SM = c_{gc} K_1 M / f_b \quad \text{cm}^3 \text{ (in}^3\text{)}$$

$$A_s = F / f_s \quad \text{cm}^2 \text{ (in}^2\text{)}$$

where

$$c_{gc} = 0.93$$

$$K_1 = 0.9$$

$$M = p_{gc} s \ell^2 10^6 / k_1 \text{ N-cm (kgf-cm, lbf-in)}$$

$$p_{gc} = p_o + (p_{gd})_{max} \text{ N/cm}^2 \text{ (kgf/cm}^2 \text{, lbf/in}^2\text{)}$$

$$p_o = \text{cargo tank design vapor pressure, in N/cm}^2 \text{ (kgf/cm}^2 \text{, lbf/in}^2\text{), as defined in 3-1/3.11}$$

$$p_{gd} = a_\beta Z_\beta k_3 \rho 10^{-4} \text{ N/cm}^2 \text{ (kgf/cm}^2 \text{, lbf/in}^2\text{)}$$

$$a_\beta = \text{dimensionless acceleration, see 3-3/5.9.2}$$

$$Z_\beta = \text{largest cargo tank liquid head in m (ft) above the point on the inner bottom transverse under consideration, see 3-3/5.9.2}$$

$$k_3 = 9.81 \text{ (1.0, 69.44)}$$

$$\rho = \text{maximum cargo density, in N/m}^3 \text{ (kgf/m}^3 \text{, lbf/ft}^3\text{), at the design temperature, but } \rho \text{ is not to be taken less than } 4900 \text{ N/m}^3 \text{ (500 kgf/m}^3 \text{, 31.214 lbf/ft}^3\text{)}$$

$$s = \text{spacing of the transverse, in m (ft)}$$

$$\ell = \text{span of the transverse as defined in 3-4/7.3.1, in m (ft)}$$

$$k_1 = 10 \text{ (10, 5780)}$$

$$f_b = \text{permissible bending stress, in N/cm}^2 \text{ (kgf/cm}^2 \text{, lbf/in}^2\text{)}$$

$$= S_{gc}f_y$$

$$S_{gc} = 0.64 \quad \text{for Ordinary strength steel}$$

$$= 0.53 \quad \text{for H32 strength steel}$$

$$= 0.52 \quad \text{for H36 strength steel}$$

$$f_y = \text{minimum specified yield point for the transverses, in N/cm}^2 \text{ (kgf/cm}^2, \text{ lbf/in}^2)$$

$$F = k_2 6000 p_{gc} s \ell \text{ N (kgf, lbf)}$$

$$k_2 = 1.0 \text{ (1.0, 0.0145)}$$

$$f_s = \text{permissible shear stress, in N/cm}^2 \text{ (kgf/cm}^2, \text{ lbf/in}^2)$$

$$= 0.4 S_m f_y$$

$$S_m = \text{strength reduction factor for the transverses, as defined in 3-4/7.3.1}$$

The net thickness of the web plate of the transverse is not to be less than t_1 obtained in 3-4/7.7.4, adjusted for the material of the web plate.

The thickness and material properties of the web plate in line with the cofferdam bulkheads are to be at least 75% of those provided for the lowest strake of the cofferdam bulkhead plating.

7.9.3 Vertical Web on Watertight Girder in Double Bottom

A vertical web on a double bottom watertight girder is to have a section modulus, SM , and a cross sectional area, A_s , not less than obtained from the following equations:

$$SM = M/f_b \quad \text{cm}^3(\text{in}^3)$$

$$A_s = F/f_s \quad \text{cm}^2(\text{in}^2)$$

where

$$M = p s \ell^2 10^5 / k_1 \text{ N-cm (kgf-cm, lbf-in)}$$

p = nominal pressure at mid-span of the vertical web, in kN/m^2 (tf/m^2 , Ltf/ft^2), as specified in 3-3/Table 3.

s = spacing of the vertical web, in m (ft)

ℓ = span of the vertical web as defined in 3-4/Figure 7, in m (ft)

$$k_1 = 12 \text{ (12, 44.64)}$$

f_b = permissible bending stress, in N/cm^2 (kgf/cm^2 , lbf/in^2)

$$= 0.6 S_m f_y$$

S_m = strength reduction factor for the material of the vertical web, as defined in 3-4/7.3.1

f_y = minimum specified yield point for the material of the vertical web, in N/cm^2 (kgf/cm^2 , lbf/in^2)

$$F = k_2 500 p s \ell \text{ N (kgf, lbf)}$$

$$k_2 = 1.0 \text{ (1.0, 2.24)}$$

$$\begin{aligned} f_s &= \text{permissible shear stress, in N/cm}^2 \text{ (kgf/cm}^2, \text{ lbf/in}^2\text{)} \\ &= 0.4S_m f_y \end{aligned}$$

The net thickness of the web plate of the vertical web is not to be less than t_1 obtained in 3-4/7.7.4, adjusted for the material of the web plate.

FIGURE 3
Unsupported Span of Longitudinal

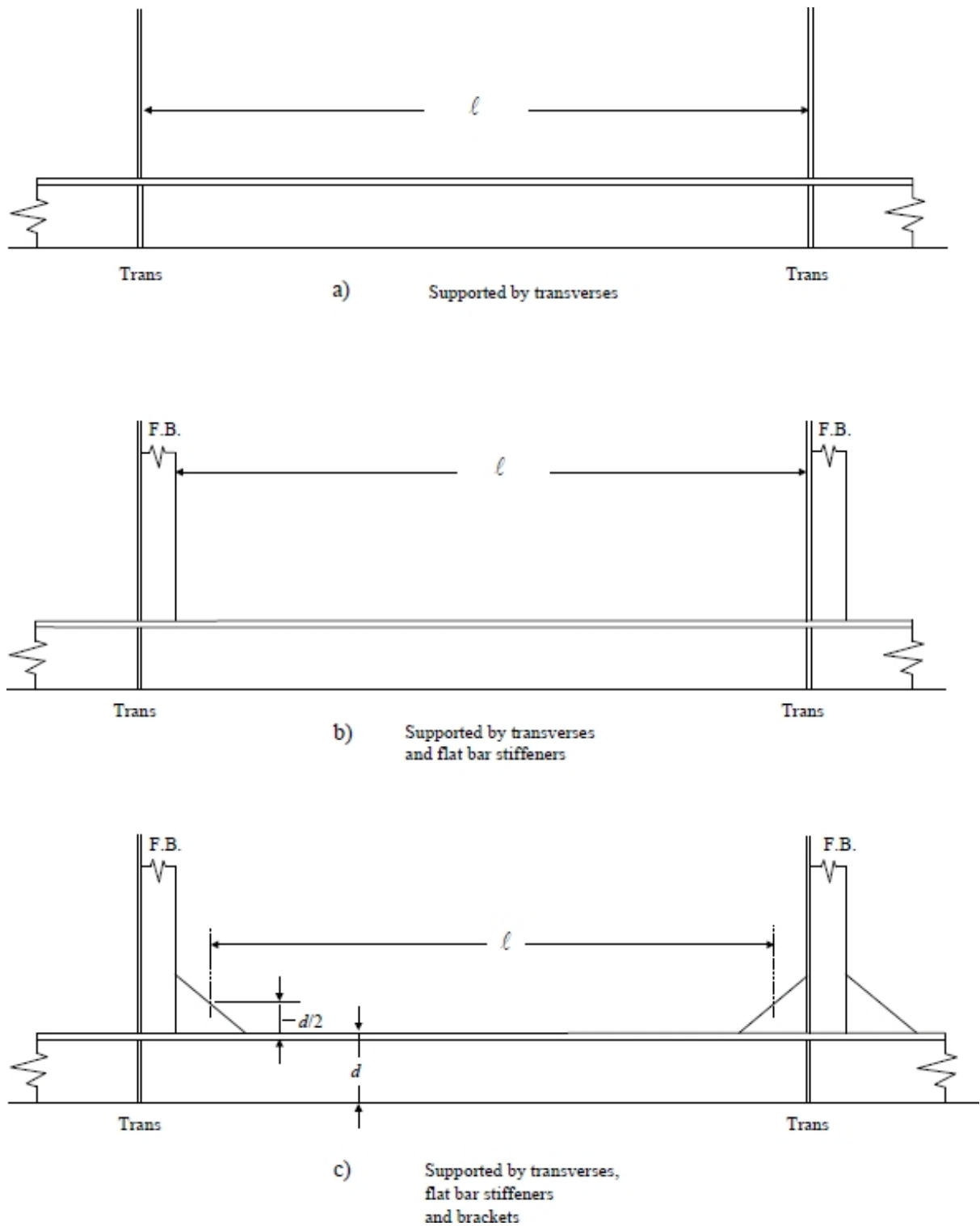
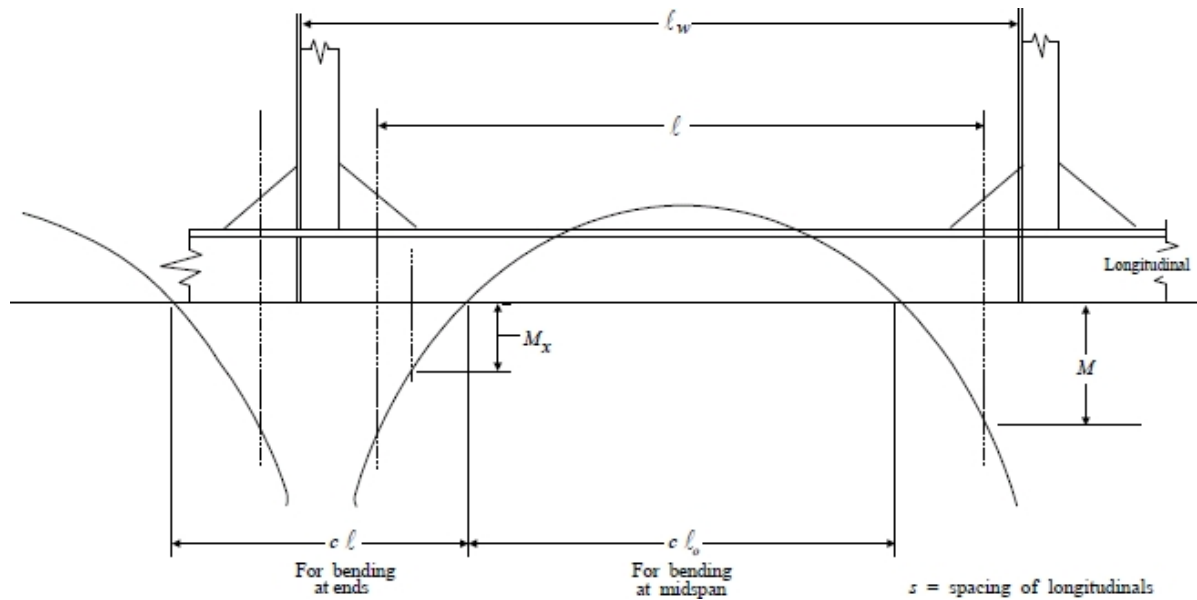

FIGURE 4
Effective Breadth of Plating b_e



a) For bending at midspan

$c l_o / s$	1.5	2	2.5	3	3.5	4	4.5 and greater
b_e / s	0.58	0.73	0.83	0.90	0.95	0.98	1.0

b) For bending at ends

$c l / s$	1	1.5	2	2.5	3	3.5	4.0
b_e / s	0.25	0.35	0.43	0.5	0.55	0.6	0.67

a) is for strength evaluation and b) is for fatigue strength assessment.

TABLE 1
Minimum Net Thickness of Girders and Floors

L meters	t_{min} mm	L feet	t_{min} in.
90	7.5	278	0.29
110	8	344	0.31
150	9	478	0.35
190 and more	10	644 and more	0.40

Alternatively, t_{min} may be determined from the following equation:
 $t_{min} = 2.5L \cdot 10^{-2} + 5.25 \text{ mm}$ ($t_{min} = 3.0L10^{-4} + 0.2067 \text{ in.}$)
 Where L is scantling length in m (ft) but need not be taken greater than 190 m (644 ft)

FIGURE 5
 Definitions of ℓ_s and b_{DB}

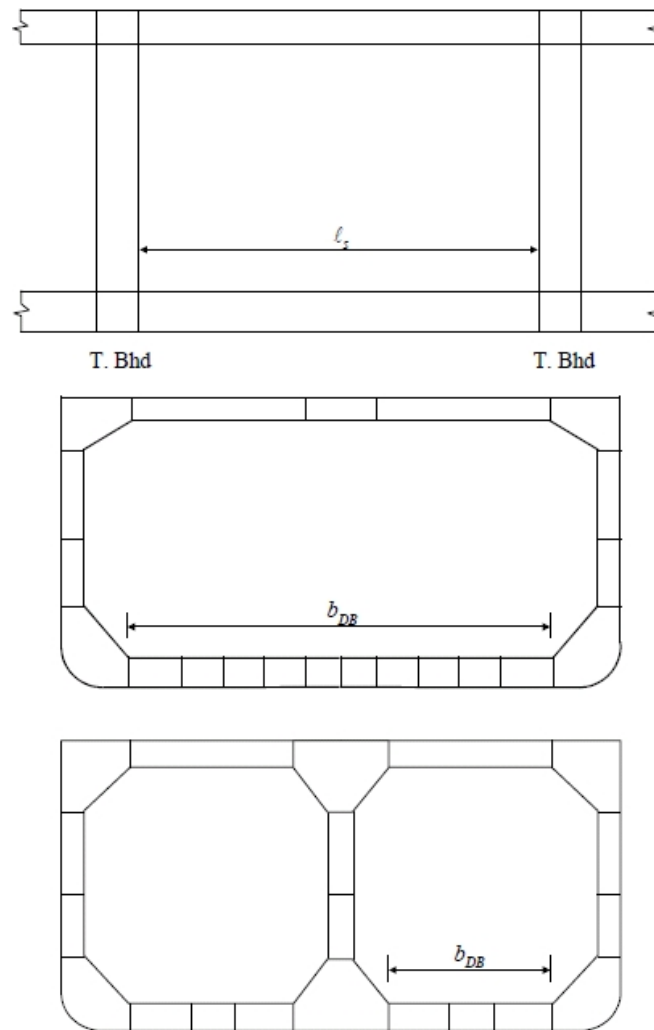

9 Side Shell and Deck

9.1 Side Shell Plating (1 June 2014)

The net thickness of the side shell plating over the midship $0.4L$, in addition to complying with 3-4/5.3, is to be not less than t_1 , t_2 , t_3 nor t_4 , as specified below:

$$t_1 = 0.73s (k_1 p / f_1)^{1/2*} \text{ mm (in.)}$$

$$t_2 = 0.73s (k_2 p / f_2)^{1/2*} \text{ mm (in.)}$$

$$t_3 = cs (S_m f_y / E)^{1/2**} \text{ mm (in.)}$$

$$t_4 = 0.73s (k_2 p_i / f_2)^{1/2} \text{ mm (in.)}$$

Note:

* The net thickness t_1 and t_2 as calculated for each plate, need not exceed the values calculated at the upper turn of the bilge, adjusted for the spacing of the longitudinals and material factors.

** The net thickness, t_3 , may be determined based on S_m and f_y of the hull girder strength material required at the location under consideration.

where

s = spacing of side longitudinals, in mm (in.)

k_1 = 0.342

k_2 = 0.50

p = $p_a - p_{uo}$ or p_b , whichever is greater, in N/cm^2 (kgf/cm^2 , lbf/in^2)

p_{uo} = $0.24\gamma(h\ell_{wt}b_{wt}\tan\phi_e\tan\theta_e)^{1/3}$ where $\ell_{wt} \geq 0.20L$

= 0 where $\ell_{wt} \leq 0.15L$

Linear interpolation is to be used for intermediate values of ℓ_{wt} .

Where the top of the double side ballast tank does not extend to the exposed deck, p_{uo} is to be taken as zero.

p_a, p_b = nominal pressures at the lower edge of each plate, in N/cm^2 (kgf/cm^2 , lbf/in^2), as defined in load case “a” and “b” in 3-3/Table 3 for side shell plating adjacent to ballast tank; and as defined in load case “b” in 3-3/Table 3 for side shell plating adjacent to passage way or void space, but are not to be less than 65% of those calculated at upper turn of bilge.

b_{wt} = breadth at tank top of double side ballast tank, in m (ft)

ϕ_e = effective pitch amplitude, as defined in 3-3/5.7.2 with $C_\phi = 0.7$

θ_e = effective roll amplitude, as defined in 3-3/5.7.2 with $C_\theta = 0.7$

L = scantling length of vessel, in m (ft), as defined in 3-1-1/3.1 of the *Marine Vessel Rules*

γ = specific weight of ballast water, $1.005 N/cm^2\cdot m$ ($0.1025 kgf/cm^2\cdot m$, $0.4444 lbf/in^2\cdot ft$)

h = height of double side ballast tank at vessel’s side, in m (ft)

ℓ_{wt} = length of double side ballast tank in m (ft) measured at the top of the tank

f_1 = permissible bending stress in the longitudinal direction:

$$= [0.86 - 0.50\alpha_1(SM_{RB}/SM_B)(y/y_b)]S_m f_y$$

$$\leq f_{max} \quad \text{for } L \geq 190 \text{ m (623 ft), below neutral axis}$$

$$\leq [0.43 + 0.17(190 - L)/40]S_m f_y, \quad \text{for } L < 190 \text{ m (623 ft), below neutral axis}$$

SM_B/SM_{RB} is not to be taken more than 1.4.

$$= f_{max} \quad \text{for } L \geq 190 \text{ m (623 ft), above neutral axis}$$

$$= [0.43 + 0.17(190 - L)/40]S_m f_y \quad \text{for } L < 190 \text{ m (623 ft), above neutral axis}$$

$$f_{max} = 0.43S_m f_y \quad 0.4L \text{ amidships}$$

$$= 0.65S_m f_y \quad \text{Aft end to the aft peak bulkhead}$$

$$= 0.60S_m f_y \quad \text{Fore peak bulkhead to the fore end}$$

Linear interpolation is to be used for the intermediate location.

$$f_2 = \text{permissible bending stress, in the vertical direction, in N/cm}^2 \text{ (kgf/cm}^2 \text{, lbf/in}^2\text{)}$$

$$= 0.85S_m f_y \quad 0.4L \text{ amidships}$$

$$= 0.85S_m f_y \quad \text{Fore peak bulkhead to the fore end}$$

$$= 1.00S_m f_y \quad \text{Aft end to the aft peak bulkhead}$$

Linear interpolation is to be used for the intermediate location.

$$\alpha_1 = S_{m1} f_{y1} / S_m f_y$$

S_m = strength reduction factor obtained from 3-4/7.3.1 for the steel grade of side shell plating material

S_{m1} = strength reduction factor obtained from 3-4/7.3.1 for the steel grade of bottom flange material

f_y = minimum specified yield point of side shell material, in N/cm² (kgf/cm², lbf/in²)

f_{y1} = minimum specified yield point of the bottom flange material, in N/cm² (kgf/cm², lbf/in²)

SM_{RD} = reference net hull girder section modulus based on the material factor of the upper deck flange (inner and upper decks) of the hull girder, in cm²-m (in²-ft)

$$= 0.92SM$$

SM = required gross hull girder section modulus at upper deck at side in accordance with 3-4/3.5.1, based on the material factor of the upper deck flange (inner and upper decks) of the hull girder, in cm²-m (in²-ft)

SM_D = net design hull girder section modulus amidships at the upper deck, in cm²-m (in²-ft)

$$c = 0.7N^2 - 0.2, \text{ not to be less than } 0.4Q^{1/2}$$

N = $R_d(Q/Q_d)^{1/2}$ for the sheer strake

$$= R_d[(Q/Q_d)(y_a/y_n)]^{1/2}$$
 for other locations above the neutral axis
$$= R_b[(Q/Q_b)(y_a/y_n)]^{1/2}$$
 for locations below the neutral axis

R_d = $(SM_{RDS}/SM_D)^{1/2}$

R_b = $(SM_{RBH}/SM_B)^{1/2}$

Q, Q_d = material conversion factor in 3-4/5 for the side shell plating under consideration and the upper flange (inner and upper decks) of the hull girder, respectively.

Q_b = material conversion factor in 3-4/5.1 for the bottom flange of the hull girder.

y = vertical distance, in m (ft), measured from the neutral axis of the hull girder transverse section to the lower edge of the side shell strake under consideration.

y_a = vertical distance, in m (ft), measured from the neutral axis of the hull girder transverse section to the lower edge (upper edge) of the side shell strake, where the strake under consideration is below (above) the neutral axis.

y_b = vertical distance, in m (ft), measured from the upper turn of the bilge to the neutral axis of the hull girder transverse section.

- y_n = vertical distance, in m (ft), measured from the bottom (upper deck) to the neutral axis of the hull girder transverse section, where the strake under consideration is below (above) the neutral axis
- SM_{RDS} = reference net hull girder section modulus at upper deck at side for sagging bending moment, based on the material factor of the upper deck flange (inner and upper decks) of the hull girder, in $\text{cm}^2\text{-m}$ ($\text{in}^2\text{-ft}$)
 = $0.92SM_S$
- SM_S = required hull girder section modulus at upper deck at side in accordance with 3-4/3.5.1 for sagging total bending moment based on the material factor of the upper flange (inner and upper decks) of the hull girder, in $\text{cm}^2\text{-m}$ ($\text{in}^2\text{-ft}$)
- SM_{RB} = reference net hull girder section modulus based on the material factor of the bottom flange of the hull girder, in $\text{cm}^2\text{-m}$ ($\text{in}^2\text{-ft}$)
 = $0.92SM_B$
- SM_B = net design hull girder section modulus to the bottom, in $\text{cm}^2\text{-m}$ ($\text{in}^2\text{-ft}$)
- E = modulus of elasticity of the material, may be taken as $2.06 \times 10^7 \text{ N/cm}^2$ ($2.1 \times 10^6 \text{ kgf/cm}^2$, $30 \times 10^6 \text{ lbf/in}^2$) for steel
- R_b = $(SM_{RBH}/SM_B)^{1/2}$
- SM_{RBH} = reference net hull girder section modulus for hogging bending moment based on the material factor of the bottom flange of the hull girder, in $\text{cm}^2\text{-m}$ ($\text{in}^2\text{-ft}$)
 = $0.92SM_H$
- SM_H = required hull girder section modulus in accordance with 3-2-1/3.7.1 and 3-2-1/5.5 of the *Marine Vessel Rules*, for hogging total bending moment based on the material factor of the bottom flange of the hull girder, in $\text{cm}^2\text{-m}$ ($\text{in}^2\text{-ft}$)
- p_i = pressure, in N/cm^2 (kgf/cm^2 , lbf/in^2)
 = $0.88(0.098L + 90.2D/L - 9.8)$ for SI units
 = $0.88(0.01L + 9.02D/L - 1.0)$ for MKS units
 = $0.88(0.04335L + 130.9D/L - 14.223)$ for US units
 for the side shell plating located $\geq 3 \text{ m}$ (10 ft) above the summer load line, p_i may be reduced by 20%
- D = depth of vessel, in m (ft), as defined in 3-1-1/7.1 of the *Marine Vessel Rules*

Note:

* The net thickness t_1 and t_2 as calculated for each plate, need not exceed the values calculated at the upper turn of the bilge, adjusted for the spacing of the longitudinals and material factors.

** The net thickness, t_3 , may be determined based on S_m and f_y of the hull girder strength material required at the location under consideration.

In addition, the net thickness of the side shell plating subject to side offloading is not to be taken less than t_5 obtained from the following equation:

$$t_5 = 90(s/1000 + 0.7)[Bd/(S_m f_y)^2]^{1/4} + t_k \text{ mm}$$

$$t_5 = 7.3(s/39.4 + 0.7)[Bd/(S_m f_y)^2]^{1/4} + t_k \text{ in.}$$

where

s	=	spacing of side longitudinal stiffeners, in mm (in)
B	=	breadth of installation, as defined in 3-1-1/5 of the <i>Marine Vessel Rules</i> , in m (ft)
d	=	molded draft, as defined in 3-1-1/9 of the <i>Marine Vessel Rules</i> , in m (ft)
t_k	=	0.5 mm (0.02 in.) for mild steel
	=	1.0 mm (0.04 in.) for Grade H32 steel
	=	1.5 mm (0.06 in.) for Grade H36 steel
	=	2.0 mm (0.08 in.) for Grade H40 steel

All other parameters are as defined above.

The net thickness, t_5 , is to be applied to the following extent of the side shell plating:

- *Longitudinal extent.* Between a section aft of amidships where the breadth at the waterline exceed $0.9B$, and a section forward of amidships where the breadth at the waterline exceeds $0.6B$.
- *Vertical extent.* Between 300 mm below the lowest ballast waterline to $0.25d$ or 2.2 m, whichever is greater, above the summer load line.

Alternatively, in lieu of the t_5 requirements above, side shell strength calculations may be submitted to demonstrate the structural adequacy of the side shell to the impact absorbing characteristics of fenders or equivalent, and their arrangement.

9.3 Sheerstrake

The minimum width, b , of the sheerstrake throughout the amidships $0.4L$ is to be obtained from the following equation:

$$b = 5.0 L \times 10^{-3} + k \text{ m (ft)}$$

where

L	=	scantling length of vessel, in m (ft), as defined in 3-1-1/3.1 of the <i>Marine Vessel Rules</i> , but need not be taken greater than 200 m (656 ft) in the above equation
k	=	0.8 (2.625)

In general, the thickness of the sheerstrake is not to be less than the thickness of the adjacent side shell plating. The thickness of the sheerstrake is to be increased 25% in way of breaks of superstructures, but this increase need not exceed 6.35 mm (0.25 in.).

9.5 Deck Plating

9.5.1 Upper Deck - Net Thickness (1 June 2014)

The net thickness of the upper deck plating is not to be less than is required to meet the hull girder section modulus requirement in 3-2-1/3.7 of the *Marine Vessel Rules*. The buckling and ultimate strength are to be in accordance with the requirements in 3-5/5. In addition, the net thickness of the upper deck plating, over the midship $0.4L$, is not to be less than t_1 , t_2 nor t_3 as specified below:

$$t_1 = 0.73s(k_1 p / f_1)^{1/2} \text{ mm (in.)}$$

$$t_2 = 0.73s(k_2p/f_2)^{1/2} \text{ mm (in.)}$$

$$t_3 = cs(S_m f_y/E)^{1/2*} \text{ mm (in.)}$$

where

- s = spacing of deck longitudinals, in mm (in.)
- k_1 = 0.342
- k_2 = 0.50
- p = 2.06 N/cm² (0.21 kgf/cm², 2.987 lbf/in²), in way of void space between upper deck and inner deck
 In no case is p to be taken less than 2.06 N/cm² (0.21 kgf/cm², 2.987 lbf/in²).
- f_1 = permissible bending stress, in the longitudinal direction, in N/cm² (kgf/cm², lbf/in²)
 = 0.30 $S_m f_y$, for upper deck
- S_m = strength reduction factor for the upper deck plating material under consideration and the strength reduction factor for the upper flange of the hull girder, respectively
 = 1.0 for ordinary strength steel
 = 0.95 for H32 strength steel
 = 0.908 for H36 strength steel
- f_y = minimum specified yield point of upper deck plating material, in N/cm² (kgf/cm², lbf/in²)
- f_2 = permissible bending stress, in the transverse direction, in N/cm² (kgf/cm², lbf/in²)
 = 0.80 $S_m f_y$
- c = where the inner deck is not installed: 0.4 L amidships
 0.5 (0.6 + 0.0015 L) for SI or MKS Units
 0.5 (0.6 + 0.00046 L) for U.S. Units
 c is not to be taken less than (0.7 N^2 - 0.2) for installations having length less than 267 m (876 ft)
 = where the inner deck is installed: 0.4 L amidships
 = 0.7 N^2 - 0.2, not to be less than 0.40 $Q^{1/2}$
 = 0.30 $Q^{1/2}$ Peak bulkhead to the end

Linear interpolation is to be used for the intermediate location.

$$N = R_d(Q/Q_d)^{1/2}$$

$$R_d = (SM_{RDS}/SM_D)^{1/2}$$

Q, Q_d = material conversion factor in 3-4/5 for the upper deck plating under consideration and the upper flange (inner and upper deck) of the hull girder, respectively

E = modulus of elasticity of the material, may be taken as 2.06 × 10⁷ N/cm² (2.1 × 10⁶ kgf/cm², 30 × 10⁶ lbf/in²) for steel

- SM_{RDS} = reference net hull girder section modulus at upper deck at side for sagging bending moment, based on the material factor of the upper flange (inner and upper deck) of the hull girder, in $\text{cm}^2\text{-m}$ ($\text{in}^2\text{-ft}$)
- = $0.92SM_S$
- SM_S = required hull girder section modulus at upper deck at side in accordance with 3-4/3.5.1 for sagging total bending moment based on the material factor of the upper flange (inner and upper deck) of the hull girder, in $\text{cm}^2\text{-m}$ ($\text{in}^2\text{-ft}$).
- SM_D = net design hull girder section modulus amidships at the upper deck at side, in $\text{cm}^2\text{-m}$ ($\text{in}^2\text{-ft}$)

Note:

* The net thickness, t_3 , may be determined based on S_m and f_y of the hull girder strength material required at the location under consideration.

The t_3 requirement for a floating offshore liquefied gas terminal may be adjusted based on the ratio M_r , where: $M_r = (\text{maximum sagging still-water bending moment} + \text{sagging wave bending moment for the on-site DEC}) / (\text{maximum sagging still-water bending moment} + \text{wave sagging bending moment for North Atlantic environment})$. The sagging wave bending moment may be obtained from 3-3/5.1.1.

M_r	Adjusted t_3
$M_r < 0.7$	$0.85 * t_3$
$0.7 \leq M_r \leq 1.0$	$(0.5 + M_r/2) * t_3$
$M_r > 1.0$	$1.0 * t_3$

The required deck area is to be maintained throughout the midship $0.4L$ of the vessel. From these locations to the ends of the vessel the deck area may be gradually reduced in accordance with 3-2-1/11.3 of the *Marine Vessel Rules*.

9.5.2 Inner Deck - Net Thickness (1 September 2012)

The net thickness of the inner deck plating, t_n , is to be not less than needed to meet the hull girder section modulus requirement in 3-2-1/3.7 of the *Marine Vessel Rules*. The buckling and ultimate strength are to be in accordance with the requirements in 3-5/5. Additionally, the net thickness of the inner deck plating, t_n , is to be not less than t_1, t_2, t_3 nor t_4 specified as follows:

$$t_1 = 0.73s(k_1p/f_1)^{1/2} \text{ mm (in.)}$$

$$t_2 = 0.73sk(k_2p/f_2)^{1/2} \text{ mm (in.)}$$

$$t_3 = cs(S_m f_y / E)^{1/2*} \text{ mm (in.)}$$

$$t_4 = 0.73sk(k_2p_{gc}/f)^{1/2} \text{ mm (in.)}$$

Where the inner deck plating is transversely stiffened locally, the net thickness of the inner deck plating, t_n , is to be not less than t_5 or t_6 , specified as follows:

$$t_5 = 0.73s_t k(k_2p/f_1)^{1/2} \text{ mm (in.)}$$

$$t_6 = 0.73s_t k (k_2 p_{gc}/f)^{1/2} \text{ mm (in.)}$$

where

- s = spacing of inner deck longitudinals, in mm (in.)
- s_t = spacing of inner deck transverse stiffeners, in mm (in.)
- k_1 = 0.342
- k = $(3.075\sqrt{\alpha} - 2.077)/(\alpha + 0.272)$ ($1 \leq \alpha \leq 2$)
 = 1.0 ($\alpha > 2$)
- α = aspect ratio of the plate panel (longer edge/shorter edge)
- p = p_n in way of cargo tank
 In no case is p to be taken less than 2.50 N/cm² (0.255 kgf/cm², 3.626 lbf/in²) for cargo tank.
- p_n = nominal pressure, in N/cm² (kgf/cm²lbf/in²), as defined in 3-3/Table 3 for deck plating.
- f_1 = permissible bending stress, in the longitudinal direction, in N/cm² (kgf/cm², lbf/in²)
 = $[1.0 - 0.82\alpha_2]S_m f_y \leq 0.18S_m f_y$,
- f_2 = permissible bending stress, in the transverse direction, in N/cm² (kgf/cm², lbf/in²)
 = 0.80 $S_m f_y$
- f = permissible bending stress, in N/cm² (kgf/cm², lbf/in²)
 = 0.70 f_y
- α_2 = $S_{m2} f_{y2}/S_m f_y$
- S_m, S_{m2} = strength reduction factor for the inner deck plating material under consideration and the strength reduction factor for the upper flange (inner and upper deck) of the hull girder, respectively
 = 1.0 for ordinary strength steel
 = 0.95 for H32 strength steel
 = 0.908 for H36 strength steel
- f_y = minimum specified yield point of inner deck plating material, in N/cm² (kgf/cm², lbf/in²)
- f_{y2} = minimum specified yield point of the upper flange (inner and upper deck) of the hull girder, in N/cm² (kgf/cm², lbf/in²)
- c = $0.7N^2 - 0.2$, not to be less than $0.37Q^{1/2}$
- N = $R_d(Q/Q_d)^{1/2}$
- R_d = $(SM_{RDS}/SM_D)^{1/2}$
- Q, Q_d = material conversion factor for the inner deck plating under consideration and the upper flange (inner and upper deck) of the hull girder, respectively
 = 1.0 for ordinary strength steel

- γ = 0.78 for H32 strength steel
- γ = 0.72 for H36 strength steel
- E = modulus of elasticity of the material, may be taken as 2.06×10^7 N/cm² (2.1×10^6 kgf/cm², 30×10^6 lbf/in²) for steel
- SM_{RDS} = reference net hull girder section modulus at upper deck at side for sagging bending moment, based on the material factor of the upper flange (inner and upper deck) of the hull girder, in cm²-m (in²-ft)
- SM_{RDS} = $0.92SM_S$
- SM_S = required hull girder section modulus at upper deck at side in accordance with 3-4/3.5.1 for sagging total bending moment based on the material factor of the upper flange (inner and upper deck) of the hull girder, in cm²-m (in²-ft).
- SM_D = net design hull girder section modulus amidships at the upper deck at side, in cm²-m (in²-ft)
- p_{gc} = $p_o + (p_{gd})_{max}$ N/cm² (kgf/cm², lbf/in²)
- p_o = cargo tank design vapor pressure in N/cm² (kgf/cm², lbf/in²)
- p_{gd} = $a_\beta Z_\beta k_3 \rho 10^{-4}$ N/cm² (kgf/cm², lbf/in²)
- a_β = dimensionless acceleration, see 3-3/5.9.2
- Z_β = largest cargo tank liquid head in m (ft) above the point on the inner deck under consideration, see 3-3/5.9.2
- k_3 = 9.81(1.0, 69.44)
- ρ = maximum cargo density, in N/m³ (kgf/m³, lbf/ft³), at the design temperature, but ρ is not to be taken less than 4900 N/m³ (500 kgf/m³, 31.214 lbf/ft³)

Note:

* The net thickness, t_3 , may be determined based on S_m and f_y of the hull girder strength material required at the location under consideration.

The t_3 requirement for a floating offshore liquefied gas terminal may be adjusted based on the ratio M_r , where: $M_r = (\text{maximum sagging still-water bending moment} + \text{sagging wave bending moment for the on-site DEC}) / (\text{maximum sagging still-water bending moment} + \text{wave sagging bending moment for North Atlantic environment})$. The sagging wave bending moment may be obtained from 3-3/5.1.1.

M_r	Adjusted t_3
$M_r < 0.7$	$0.85 * t_3$
$0.7 \leq M_r \leq 1.0$	Varies linearly between $0.85 * t_3$ and t_3
$M_r > 1.0$	$1.0 * t_3$

The net thickness of the sloping side and tank top plates of the inner deck is also to comply with the requirements for t_1 and t_2 in 3-4/13.1.

The required deck area is to be maintained throughout the midship $0.4L$ of the vessel. From these locations to the ends of the vessel the deck area may be gradually reduced in accordance with 3-2-1/11.3 of the *Marine Vessel Rules*.

9.5.3 Underdeck Passageway (Second Deck) - Net Thickness

The net thickness of the passage deck is to be not less than t_1 , t_2 , t_3 , nor t_4 , as specified below:

$$t_1 = 9.0 \text{ mm} \quad \text{for } L \geq 200 \text{ m}$$

$$= 0.02L + 5.0 \text{ mm} \quad \text{for } 200 \text{ m} \geq L \geq 150 \text{ m}$$

$$t_1 = 0.354 \text{ in.} \quad \text{for } L \geq 656 \text{ ft}$$

$$= 0.00024L + 0.2 \text{ in.} \quad \text{for } 656 \text{ ft} \geq L \geq 492 \text{ ft}$$

$$t_2 = 0.73s(k_1p/f_1)^{1/2} \text{ mm (in.)}$$

$$t_3 = 0.73sk(k_2p/f_2)^{1/2} \text{ mm (in.)}$$

$$t_4 = cs(S_m f_y/E)^{1/2} \text{ mm (in.)}$$

where

$$s = \text{spacing of longitudinals, in mm (in.)}$$

$$k_1 = 0.342$$

$$k_2 = 0.50$$

$$k = \frac{(3.075(\alpha)^{1/2} - 2.077)}{(\alpha + 0.272)} \quad (1 \leq \alpha \leq 2)$$

$$= 1.0 \quad (\alpha > 2)$$

$$\alpha = \text{aspect ratio of the panel (longer edge/shorter edge)}$$

$$p = p_a - p_{uh}, \text{ in N/cm}^2 \text{ (kgf/cm}^2, \text{ lbf/in}^2)$$

p_a is nominal pressure, in N/cm² (kgf/cm², lbf/in²), as defined in 3-3/Table 3.

p_{uh} is also defined in 3-4/7.3.1.

$$c = 0.7N^2 - 0.2, \text{ not to be less than } 0.2$$

$$N = R_d[(Q/Q_d)(y/y_n)]^{1/2}$$

$$R_d = (SM_{RDS}/SM_D)^{1/2}$$

$$f_1 = \text{permissible bending stress, in the longitudinal direction, in N/cm}^2 \text{ (kgf/cm}^2, \text{ lbf/in}^2)$$

$$= [1.0 - 0.67\alpha_2(SM_{RD}/SM_D)(y/y_n)]S_m f_y \leq 0.65S_m f_y$$

$$f_2 = \text{permissible bending stress, in the transverse direction, in N/cm}^2 \text{ (kgf/cm}^2, \text{ lbf/in}^2)$$

$$= 0.90S_m f_y$$

$$\alpha_2 = S_{m2} f_{y2}/S_m f_y$$

$$S_m = \text{strength reduction factor of the longitudinal bulkhead plating}$$

S_{m2}	=	strength reduction factor for the upper flange (inner and upper deck) of the hull girder
f_y	=	minimum specified yield point of the second deck plating, in N/cm ² (kgf/cm ² , lbf/in ²)
f_{y2}	=	minimum specified yield point of the upper flange (inner and upper deck) of the hull girder, in N/cm ² (kgf/cm ² , lbf/in ²)
Q, Q_d	=	material conversion factor for the second deck plating and the upper flange (inner and upper deck) of the hull girder, respectively
y	=	vertical distance, in m (ft), measured from the second deck plating under consideration to the neutral axis of the hull girder section
y_n	=	vertical distance, in m (ft), measured from the upper deck at side to the neutral axis of the hull girder section
SM_{RD}	=	reference net hull girder section modulus at upper deck at side based on material factor of the upper flange (inner and upper decks) of the hull girder, in cm ² -m (in ² -ft)
	=	$0.92SM$
SM	=	required gross hull girder section modulus at upper deck at side in accordance with 3-4/3.5.1, based on the material factor of the upper flange (inner and upper decks) of the hull girder, in cm ² -m (in ² -ft)
SM_{RDS}	=	reference net hull girder section modulus at upper deck at side for sagging bending moment, based on the material factor of the upper flange (inner and upper deck) of the hull girder, in cm ² -m (in ² -ft)
	=	$0.92SM_S$
SM_S	=	required hull girder section modulus at upper deck at side in accordance with 3-4/3.5.1 for sagging total bending moment based on the material factor of the upper flange (inner and upper deck) of the hull girder, in cm ² -m (in ² -ft).
SM_D	=	net design hull girder section modulus amidships at the upper deck at side, in cm ² -m (in ² -ft)

9.7 Deck and Side Longitudinals (1 June 2014)

The net section modulus of each individual side or deck longitudinal, in association with the effective plating to which it is attached, is to be not less than obtained from the following equation:

$$SM = M / f_b \quad \text{cm}^3(\text{in}^3)$$

where

$$M = 1000ps^2/k \text{ N-cm (kgf-cm, lbf-in)}$$

$$k = 12 (12, 83.33)$$

$$p = p_a - p_{uo} \text{ or } p_b$$

whichever is greater, for side longitudinals, in N/cm² (kgf/cm², lbf/in²)

$$= p_n - p_{uh}$$

for second deck longitudinals in ballast tank, in N/cm² (kgf/cm², lbf/in²)

$$= p_n$$

for deck longitudinal in cargo tank, in N/cm² (kgf/cm², lbf/in²)

In no case is p to be taken less than 2.06 N/cm^2 (0.21 kgf/cm^2 , 2.987 lbf/in^2) for ballast tank and void space, nor 2.50 N/cm^2 (0.255 kgf/cm^2 , 3.626 lbf/in^2) for cargo tank.

p_a, p_b = nominal pressures, in N/cm^2 (kgf/cm^2 , lbf/in^2), as defined in load case “a” and “b”, at the side longitudinal considered, in 3-3/Table 3 for side longitudinals, respectively

p_n = nominal pressure, in N/cm^2 (kgf/cm^2 , lbf/in^2), as defined in 3-3/Table 3 for deck longitudinals.

p_{uo} = $0.24\gamma(h\ell_{wt}b_{wt}\tan\phi_e\tan\theta_e)^{1/3}$ where $\ell_{wt} \geq 0.20L$

= 0 where $\ell_{wt} \leq 0.15L$

Linear interpolation is to be used for intermediate values of ℓ_{wt} .

Where the top of the double side ballast tank does not extend to the exposed deck, p_{uo} is to be taken as zero.

p_{uh} = $0.12\gamma(h\ell_{wt}\tan\phi_e)^{1/2}$ where $\ell_{wt} \geq 0.20L$

= 0 where $\ell_{wt} \leq 0.15L$

Linear interpolation is to be used for intermediate values of ℓ_{wt} .

Where the top of the double side ballast tank does not extend to the exposed deck, p_{uh} is to be taken as zero.

γ = specific weight of the ballast water, $1.005 \text{ N/cm}^2\text{-m}$ ($0.1025 \text{ kgf/cm}^2\text{-m}$, $0.4444 \text{ lbf/in}^2\text{-ft}$)

h = height of double side ballast tank at vessel’s side, in m (ft)

ℓ_{wt} = length of double side ballast tank in m (ft) measured at the top of the tank

L = scantling length of vessel, in m (ft), as defined in 3-1-1/3.1 of the *Marine Vessel Rules*

ϕ_e = effective pitch amplitude, as defined in 3-3/5.7.2 with $C_\phi = 0.7$

θ_e = effective roll amplitude, as defined in 3-3/5.7.2 with $C_\theta = 0.7$

s = spacing of longitudinals, in mm (in.)

ℓ = span of the longitudinal between effective supports, as shown in 3-4/Figure 3, in m (ft)

f_b = permissible bending stresses, in N/cm^2 (kgf/cm^2 , lbf/in^2)

= $[1.0 - 0.82\alpha_2(SM_{RD}/SM_D)(y/y_n)]S_m f_y \leq 0.60S_m f_y$ for upper deck longitudinal

= $[1.0 - 0.82\alpha_2(SM_{RD}/SM_D)(y/y_n)]S_m f_y \leq 0.30S_m f_y$ for inner deck longitudinal

= $[1.0 - 0.67\alpha_2(SM_{RD}/SM_D)(y/y_n)]S_m f_y \leq 0.45S_m f_y$ for second deck longitudinal

= $1.0[0.86 - 0.52\alpha_1(SM_{RB}/SM_B)(y/y_n)]S_m f_y \leq f_{max}$ for side longitudinals below neutral axis

= $2.0[0.86 - 0.52\alpha_2(SM_{RD}/SM_D)(y/y_n)]S_m f_y \leq f_{max}$ for side longitudinals above neutral axis

f_{max} = $0.75S_m f_y$ 0.4L amidships

= $0.90S_m f_y$ Aft end to the aftpeak bulkhead

= $0.85S_m f_y$ Forepeak bulkhead to the fore end

Linear interpolation is to be used for the intermediate location.

α_2 = $S_{m2} f_{y2} / S_m f_y$

S_m, f_y and α_1 are as defined in 3-4/7.5.

S_{m2} = strength reduction factor as obtained from 3-4/7.3.1 for the steel grade of upper flange (inner and upper decks) of the hull girder.

f_{y2} = minimum specified yield point of the upper flange (inner and upper decks) material of the hull girder, in N/cm² (kgf/cm², lbf/in²)

SM_{RD} = reference net hull girder section modulus at upper deck at side based on the material factor of the upper flange (inner and upper decks) of the hull girder, in cm²-m (in²-ft)
 = 0.92SM

SM_D = net design hull girder section modulus at upper deck at side, in cm²-m (in²-ft)

SM_{RB} and SM_B are as defined in 3-4/7.3.1.

y = vertical distance in m (ft) measured from the neutral axis of the hull girder section to the longitudinal under consideration at its connection to the associated plate but need not to be taken greater than a distance to the upper deck or inner deck at side, respectively

SM = required hull girder section modulus at upper deck at side in accordance with 3-2-1/3.7 and 3-2-1/5.5 of the *Marine Vessel Rules*, based on the material factor of the upper flange (inner and upper decks) of the hull girder, in cm²-m (in²-ft).

y_n = vertical distance, in m (ft), measured from the upper deck at side to the neutral axis of the section.

The net section modulus of inner deck longitudinals located outboard of 0.3B from the centerline of the tank is also to be not less than SM_1 of the uppermost longitudinal on the upper sloping bulkhead required by 3-4/13.5 adjusted for the span and spacing of the longitudinal and the material factors.

In addition, each inner deck longitudinal is also to have a section modulus, SM , not less than obtained from the following equations:

$$SM = c_{gc}K_1M/f_b \quad \text{cm}^3(\text{in}^3)$$

$$M = 1000p_{gc}s\ell^2/k \quad \text{N-cm(kgf-cm, lbf-in.)}$$

where

$$k = 12 (12, 83.33)$$

$$s = \text{spacing of longitudinals, in mm (in.)}$$

$$\ell = \text{span of the longitudinal between effective supports, as shown in 3-4/Figure 3, in m (ft)}$$

$$c_{gc} = \text{adjustment factor for corrosion of longitudinals in tanks}$$

$$= 0.90$$

$$= \text{adjustment factor for corrosion of longitudinals in void spaces}$$

$$= 0.94$$

$$K_1 = 0.9$$

$$p_{gc} = p_o + (p_{gd})_{max} \text{ N/cm}^2 \text{ (kgf/cm}^2 \text{, lbf/in}^2 \text{)}$$

$$p_o = \text{cargo tank design vapor pressure in N/cm}^2 \text{ (kgf/cm}^2 \text{, lbf/in}^2 \text{), as defined in 3-1/3.11}$$

$$p_{gd} = a_{\beta} Z_{\beta} k_3 \rho 10^{-4} \text{ N/cm}^2 \text{ (kgf/cm}^2, \text{ lbf/in}^2\text{)}$$

$$a_{\beta} = \text{dimensionless acceleration, see 3-3/5.9.2}$$

$$Z_{\beta} = \text{largest cargo tank liquid head, in m (ft), above the point on the inner deck longitudinal under consideration, see 3-3/5.9.2}$$

$$k_3 = 9.81(1.0, 69.44)$$

$$\rho = \text{maximum cargo density, in N/m}^3 \text{ (kgf/m}^3, \text{ lbf/ft}^3\text{), at the design temperature, but } \rho \text{ is not to be taken less than } 4900 \text{ N/m}^3 \text{ (500 kgf/m}^3, \text{ 31.214 lbf/ft}^3\text{)}$$

$$f_b = \text{permissible bending stresses, in N/cm}^2 \text{ (kgf/cm}^2, \text{ lbf/in}^2\text{)}$$

$$= S_{gc} f_y$$

$$S_{gc} = 0.64 \quad \text{for ordinary strength steel}$$

$$= 0.53 \quad \text{for Grade H32}$$

$$= 0.52 \quad \text{for Grade H36}$$

In determining compliance with the foregoing, an effective breadth, b_e , of attached plating is to be used in the calculation of the section modulus of the design longitudinal. b_e is to be obtained from line b) of 3-4/ Figure 4.

The net moment of inertia about the neutral axis of deck longitudinals and side longitudinals within the region of $0.1D_s$ from the upper deck, in association with the effective plating ($b_{wL}t_n$), is to be not less than obtained from the following equation:

$$i_o = k A_e \ell^2 f_y / E \quad \text{cm}^4 \text{ (in}^4\text{)}$$

where

$$k = 1220 \text{ (1220, 17.57)}$$

$$A_e = \text{net sectional area of the longitudinal with the associated effective plating } b_{wL}t_n, \text{ in cm}^2 \text{ (in}^2\text{)}$$

$$b_{wL} = cs$$

$$c = 2.25/\beta - 1.25\beta^2 \quad \text{for } \beta \geq 1.25$$

$$= 1.0 \quad \text{for } \beta < 1.25$$

$$\beta = (f_y/E)^{1/2} s/t_n$$

$$t_n = \text{net thickness of the plate, in mm (in.)}$$

$$D_s = \text{depth from the bottom to the upper deck at side, in m (ft).}$$

ℓ , s , and f_y are as defined in 3-4/7.5.

E is as defined in 3-4/7.3.1.

11 Side Shell and Deck - Main Supporting Members

11.1 General (2018)

The main supporting members, such as transverses and girders, are to be arranged and designed with sufficient stiffness to provide support to the vessel's hull structures. In general, the deck transverses, side transverses and bottom floors are to be arranged in one plane to form continuous transverse rings. Deck girders, where fitted, are to generally extend throughout the cargo tank spaces and are to be effectively supported at the transverse bulkheads. For deck girders and transverses with partial girders in way of transverse/cofferdam bulkheads, the minimum scantlings are alternatively determined from a grillage analysis or finite element analysis.

Generous transitions are to be provided at the intersections of main supporting members to provide smooth transmission of loads and to minimize the stress concentrations. Abrupt changes in sectional properties and sharp re-entrant corners are to be avoided. It is recommended that the intersection of the inner skin and inner bottom be accomplished by using generous sloping or large radiused bulkheads.

The thickness of the main supporting members required by this Guide is considered as the requirements of initial scantlings for deck transverses, deck girder, side transverses, side stringers and horizontal and vertical webs on transverse bulkheads, and may be reduced provided that the strength of the resultant design is verified with the subsequent total strength assessment in Chapter 3, Section 5. The structural properties of the main supporting members are to comply with the failure criteria specified in 3-5/3.

11.3 Deck Transverses

11.3.1 Depth of Double Deck

In general, the depth of the double deck at the vessel's centerline is to be not less than 80 mm/m (0.96 in./ft) of the span, ℓ_d , of the double deck transverse as shown in 3-4/Figure 6 and is to be of sufficient depth to provide ready access.

11.3.2 Web Thickness of Deck Transverses

The net web thickness of deck transverses is to be not less than obtained from the following equations:

$$t_1 = F_1 / (k_1 d_t f_s) \text{ mm (in.) but need not be taken less than 9.0 mm (0.35 in.)}$$

where

F_1 = shear force in the double deck transverse, as obtained from the equation given below.
 The required scantling t_1 may be reduced to 85%, but need not be taken less than 9.0 mm (0.35 in.), provided the strength is verified in the total strength assessment:

$$= 600k_2\beta_2 p \ell_d s_d \text{ N (kgf, lbf)}$$

$$k_1 = 10.0 (10.0, 12.0)$$

$$k_2 = 1.0 (1.0, 2.24)$$

$$\beta_2 = 2(z/\ell_d)$$

d_t = actual depth of the double deck transverse, in m (ft), as defined in 3-4/Figure 6

p = nominal pressure at the mid-span of the double deck transverse at the mid-hold location, in kN/m² (tf/m², Ltf/ft²), as specified in 3-3/Table 3.

In no case is p to be taken less than 2.05 N/cm² (0.255 kgf/cm², 3.626 lbf/in²)

ℓ_d = span of the double deck transverse, in m (ft), as shown in 3-4/Figure 6

- z = distance from the centerline of the span of the double deck transverse, ℓ_d , to the location of the double deck transverse under consideration, in m (ft), as shown in 3-4/ Figure 6
- s_d = spacing of the double deck transverse under consideration, in m (ft)
- f_s = permissible shear stresses, in N/cm² (kgf/cm², lbf/in²)
 = $0.45 S_m f_y$
- f_y = minimum specified yield point of the material, in N/cm² (kgf/cm², lbf/in²)
- S_m = strength reduction factor
 = 1.0 for ordinary strength steel
 = 0.95 for H32 strength steel
 = 0.908 for H36 strength steel

In addition to the above requirement, the net thickness of the double deck transverses is to be not less than t_2 as specified below:

$$t_2 = F_2 / (k_4 d_t f_s) \quad \text{mm (in.)}$$

where

- F_2 = shear force in the deck transverse, as obtained from finite element analyses, as specified in 3-5/9 with the additional IGC load cases in 3-5/9.7
- k_4 = 10.0 (10.0, 64.3)
- p_{gc} = $p_o + (p_{gd})_{max}$ N/cm² (kgf/cm², lbf/in²)
- p_o = cargo tank design vapor pressure in N/cm² (kgf/cm², lbf/in²), as defined in 3-1/3.11
- p_{gd} = $\alpha_\beta Z_\beta k_3 \rho 10^{-4}$ N/cm² (kgf/cm², lbf/in²)
- α_β = dimensionless acceleration, see 3-3/5.9.2
- Z_β = largest cargo tank liquid head, in m (ft), above the point on the inner deck at the mid-span of the double deck transverse (ℓ_d) at the mid-hold, see 3-3/5.9.2
- k_3 = 9.81(1.0, 69.44)
- ρ = maximum cargo density, in N/m³ (kgf/m³, lbf/ft³), at the design temperature, but ρ is not to be taken less than 4900 N/m³ (500 kgf/m³, 31.214 lbf/ft³)
- f_s = permissible shear stresses, in N/cm² (kgf/cm², lbf/in²)
 = $0.5 f_y$

All other parameters are also defined as above.

11.5 Deck Girders

11.5.1 Web Thickness of Deck Girder (2018)

The net web thickness of deck girders is to be not less than obtained from the following equation:

$$t_1 = 0.012L + 7.2 \text{ mm}$$

$$= 0.144L \times 10^{-3} + 0.283 \text{ in.}$$

but t_1 need not be taken greater than 10.5 mm (0.413 in.)

$$t_2 = F_1 / (k_1 d_g f_s) \text{ mm (in.)}$$

$$t_3 = c s (S_m f_y / E)^{1/2} \text{ mm (in.)}$$

where

F_1 = shear force in the double deck girders, as obtained from the equation given below. The required scantling t_2 may be reduced to 85% provided the strength is verified in the total strength assessment:

$$= 400 k_2 \alpha_1 \gamma_1 p \ell_s s_g \text{ N (kgf, lbf)}$$

$$\alpha_1 = 0.88 - 0.194(\ell_s / \ell_d)$$

$$\gamma_1 = 2(x / \ell_s)$$

d_g = actual depth of the double deck girder under consideration, in m (ft), as defined in 3-4/ Figure 6

ℓ_s = span of the double deck girder, in m (ft), as shown in 3-4/ Figure 6

ℓ_d = span of the double deck transverse, in m (ft), as shown in 3-4/ Figure 6

x = longitudinal distance from the mid-span of unsupported span (ℓ_s) of the double deck structure to the location of the deck girder under consideration, in m (ft)

s_g = sum of one-half of fully extended deck girder spacing on both sides of the deck girder under consideration, in m (ft)

$$c = 0.7N^2 - 0.2, \text{ not to be less than } 0.40Q^{1/2}$$

s = spacing of longitudinals, in mm (in.)

f_s = permissible shear stresses, in N/cm² (kgf/cm², lbf/in²)

$$= 0.45 S_m f_y$$

S_m = strength reduction factor, obtained from 3-4/7.3.1 for the steel grade of the deck girder

f_y = minimum specified yield point of the material for the deck girder, in N/cm² (kgf/cm², lbf/in²)

$$N = R_d [(Q / Q_d)(y / y_n)]^{1/2}$$

Q = material conversion factor defined in 3-4/5 for the deck girder under consideration

y = vertical distance, in m (ft), measured from the neutral axis of the hull girder transverse section to the upper edge of the deck girder under consideration

y_n = vertical distance, in m (ft), measured from the upper deck at side to the neutral axis of the section

The net thickness, t_3 , may be determined based on S_m and f_y of the hull girder strength material required at the location under consideration.

E is as defined in 3-4/7.3.1 R_d and Q_d are as defined in 3-4/9.1.

All other parameters are also defined in 3-4/11.3.2.

In addition to the above requirement, the net thickness of the deck girder is to be not less than t_4 as specified below:

$$t_4 = F_2 / (k_4 d_g f_s) \quad \text{mm(in.)}$$

where

F_2 = shear force in the deck girder, as obtained from finite element analyses, as specified in 3-5/9 with the additional IGC load cases in 3-5/9.7

k_4 = 10.0 (10.0, 64.3)

f_s = permissible shear stresses, in N/cm² (kgf/cm², lbf/in²)
 = 0.5 f_y

All other parameters are defined as above and in 3-4/11.3.2.

11.7 Side Transverses

11.7.1 Width of Double Side

In general, the width of the double side is to be not less than 120 mm/m (1.44 in/ft) of the span, ℓ_t , of the double side transverse as shown in 3-4/Figure 6 and is to be of sufficient width to provide ready access.

11.7.2 Web Thickness of Double Side Transverses

The net thickness of double side transverses is to be not less than obtained from the following equation:

$$t_1 = 0.012L + 7.2 \quad \text{mm}$$

$$= 0.144L \times 10^{-3} + 0.283 \quad \text{in.}$$

but t_1 need not be taken greater than 10.5 mm (0.413 in.)

$$t_2 = F_1 / (k_1 d_s f_s) \quad \text{mm (in.)}$$

where

L = length of the vessel, in m (ft), as defined in 3-1-1/3.1 of the *Marine Vessel Rules*

F_1 = shear force in the double side transverse, as obtained from the equation given below. The required scantling t_2 may be reduced to 85% provided the strength is verified in the total strength assessment:

$$= 560k_2\beta_2 p \ell_t s_t \text{ N (kgf, lbf)}$$

k_1 = 10.0 (10.0, 12.0)

k_2 = 1.0 (1.0, 2.24)

β_2 = $1 - 1.6(y_t/\ell_t)$ for $y_t/\ell_t \leq 0.25$

= 0.6 for $0.25 < y_t/\ell_t < 0.9$

- $= -0.3 + (y_t/\ell_t)$ for $y_t/\ell_t \geq 0.9$
- d_s = actual depth of the double side transverse, in m (ft), as defined in 3-4/Figure 6
- p = nominal pressure at the mid-span of the double side transverse at the mid-hold location, in kN/m^2 (tf/m^2 , Ltf/ft^2), as specified in 3-3/Table 3.
- ℓ_t = span of the double side transverse, in m (ft), as shown in 3-4/Figure 6
- y_t = distance from the lower end of the double side transverse to the location under consideration, in m (ft), as shown in 3-4/Figure 6
- s_t = spacing of the double side transverse under consideration, in m (ft)
- f_s = permissible shear stresses, in N/cm^2 (kgf/cm^2 , lbf/in^2)
- $= 0.45S_m f_y$
- f_y = minimum specified yield point of the material, in N/cm^2 (kgf/cm^2 , lbf/in^2)
- S_m = strength reduction factor
- $= 1.0$ for ordinary strength steel
- $= 0.95$ for H32 strength steel
- $= 0.908$ for H36 strength steel

In addition to the above requirement, the net thickness of the double side transverses is to be not less than t_3 as specified below:

$$t_3 = F_2 / (k_4 d_s f_s) \quad \text{mm(in.)}$$

where

- F_2 = shear force in the side transverse, as obtained from finite element analyses, as specified in 3-5/9 with the additional IGC load cases in 3-5/9.7
- k_4 = 10.0 (10.0, 64.3)
- $p_{gc} = p_o + (p_{gd})_{max}$ N/cm^2 (kgf/cm^2 , lbf/in^2)
- p_o = cargo tank design vapor pressure in N/cm^2 (kgf/cm^2 , lbf/in^2), as defined in 3-1/3.11
- $p_{gd} = a_\beta Z_\beta k_3 \rho 10^{-4}$ N/cm^2 (kgf/cm^2 , lbf/in^2)
- a_β = dimensionless acceleration, see 3-3/5.9.2
- Z_β = largest cargo tank liquid head in m (ft) above the point on the inner skin bulkhead at the mid-span of the double side transverse (ℓ_t) at the mid-hold, see 3-3/5.9.2
- k_3 = 9.81(1.0, 69.44)
- ρ = maximum cargo density, in N/m^3 (kgf/m^3 , lbf/ft^3), at the design temperature, but ρ is not to be taken less than 4900 N/m^3 (500 kgf/m^3 , 31.214 lbf/ft^3)
- f_s = permissible shear stresses, in N/cm^2 (kgf/cm^2 , lbf/in^2)
- $= 0.5f_y$

All other parameters are also defined as above.

11.7.3

The net thickness of the web portions of side transverses in the bilge part and the top side part is to be not less than t_1 as required in 3-4/11.7.2 above and the net thickness in the lower portion of the bilge part is also to be not less than t_1 as required in 3-4/7.7.4.

11.9 Side Stringers

11.9.1 Side Stringers

The net thickness of side stringers in double side structures is not to be less than t_1 , t_2 or t_3 as specified below:

$$\begin{aligned} t_1 &= 0.012L + 7.2 \text{ mm} \\ &= 0.144L \times 10^{-3} + 0.283 \text{ in.} \\ &\text{but } t_1 \text{ need not be taken greater than } 10.5 \text{ mm (0.413 in.)} \end{aligned}$$

$$t_2 = F_1 / (k_1 d_s f_s) \text{ mm (in.)}$$

$$t_3 = cs(S_m f_y / E)^{1/2} \text{ mm (in.)}$$

where

F_1 = shear force in the double side stringer, as obtained from the equation given below. The required scantling t_2 may be reduced to 85% provided the strength is verified in the total strength assessment:

$$= 240k_2\gamma_1\beta_2p\ell_t s_s \text{ N (kgf, lbf)}$$

$$\gamma_1 = -0.5 + 3(x/\ell_s) \geq 0.6$$

$$\beta_2 = 2.5(y_s/h_s) \quad \text{for } y_s/h_s \leq 0.4$$

$$= 1.0 \quad \text{for } 0.4 < y_s/h_s < 0.75$$

$$= 4(1 - y_s/h_s) \quad \text{for } y_s/h_s \geq 0.75$$

d_s = actual depth of the side stringer, in m(ft), as defined in 3-4/Figure 6

x = longitudinal distance from the mid-span of the side stringer to the location under consideration, in m (ft)

y_s = distance from the inner bottom to the side stringer under consideration, in m (ft), as shown in 3-4/Figure 6

h_s = distance from the inner bottom to the upper deck at side, as shown in 3-4/Figure 6

ℓ_t = span of the side stringer, in m (ft), as shown in 3-4/Figure 6

s_s = sum of one half of fully extended stringer spacing on both sides of the side stringer under consideration, in m (ft)

Spacing of the side stringers at the upper corner of the lower sloping bulkhead and the lower corner of the upper sloping bulkhead is to be taken $s_{s\ell}$ and s_{su} as defined in 3-4/Figure 6, respectively.

$$c = 0.7N^2 - 0.2, \text{ not to be less than } 0.30Q^{1/2}$$

- s = spacing of longitudinals, in mm (in.)
- f_s = permissible shear stresses, in N/cm² (kgf/cm², lbf/in²)
 = $0.45 S_m f_y$
- S_m = strength reduction factor, obtained from 3-4/7.3.1 for the steel grade of the side stringer
- f_y = minimum specified yield point of the side stringer material, in N/cm² (kgf/cm², lbf/in²)
- N = $R_d[(Q/Q_d)(y/y_n)]^{1/2}$ for side stringers above neutral axis
 = $R_b[(Q/Q_b)(y/y_n)]^{1/2}$ for side stringers below neutral axis
- Q = material conversion factor in 3-4/5 for the side stringer under consideration
- y = vertical distance, in m (ft), measured from the neutral axis of the hull girder transverse section to the side stringer under consideration

The net thickness, t_3 , may be determined based on S_m and f_y of the hull girder strength material required at the location under consideration.

E , R_b and Q_b are as defined in 3-4/7.3.1. R_d , Q_d and y_n are as defined in 3-4/9.1.

All other parameters are also defined in 3-4/11.7.2.

In addition to the above requirement, the net thickness of the side stringers is to be not less than t_4 as specified below:

$$t_4 = F_2 / (k_4 d_s f_s) \quad \text{mm(in.)}$$

where

- F_2 = shear force in the side stringers, as obtained from finite element analyses, as specified in 3-5/9 with the additional IGC load cases in 3-5/9.7
- k_4 = 10.0 (10.0, 64.3)
- f_s = permissible shear stresses, in N/cm² (kgf/cm², lbf/in²)
 = $0.5 f_y$

All other parameters are defined as above and in 3-4/11.7.2.

11.9.2 Watertight Side Stringer

Where the side stringer forms tank boundaries, the net thickness of the boundary plating is also to be not less than t_5 and t_6 specified as follows in addition to in 3-4/11.9.1:

$$t_5 = 0.73s(k_1 p / f_1)^{1/2} \quad \text{mm(in.)}$$

$$t_6 = 0.73sk(k_2 p / f_2)^{1/2} \quad \text{mm(in.)}$$

where

- s = spacing of longitudinals, in mm (in.)
- k_1 = 0.342

$$k_2 = 0.50$$

$$k = (3.075(\alpha)^{1/2} - 2.077)/(\alpha + 0.272) \quad (1 \leq \alpha \leq 2)$$

$$= 1.0 \quad (\alpha > 2)$$

α = aspect ratio of the panel (longer edge/shorter edge)

$$p = p_a - p_{uh}, \text{ in N/cm}^2 \text{ (kgf/cm}^2, \text{ lbf/in}^2)$$

p_a is nominal pressure, in N/cm² (kgf/cm², lbf/in²), as defined in 3-3/Table 3 for watertight side stringer.

p_{uh} is also defined in 3-4/7.3.1.

$$f_1 = \text{permissible bending stress, in the longitudinal direction, in N/cm}^2 \text{ (kgf/cm}^2, \text{ lbf/in}^2)$$

$$= [1.0 - 0.67\alpha_1(SM_{RB}/SM_B)(y/y_n) \quad \text{below neutral axis}$$

$$]S_m f_y \leq 0.65S_m f_y$$

$$= [1.0 - 0.67\alpha_2(SM_{RD}/SM_D)(y/y_n) \quad \text{above neutral axis}$$

$$]S_m f_y \leq 0.65S_m f_y$$

$$f_2 = \text{permissible bending stress, in the transverse direction, in N/cm}^2 \text{ (kgf/cm}^2, \text{ lbf/in}^2)$$

$$= 0.90S_m f_y$$

$$\alpha_1 = S_{m1} f_{y1} / S_m f_y$$

S_m = strength reduction factor obtained from 3-4/7.3.1 for the inner bottom

S_{m1} = strength reduction factor obtained from 3-4/7.3.1 for the bottom flange of the hull girder

f_y = minimum specified yield point of the inner bottom, in N/cm² (kgf/cm², lbf/in²)

f_{y1} = minimum specified yield point of the bottom flange of the hull girder, in N/cm² (kgf/cm², lbf/in²)

y = vertical distance, in m (ft), measured from the inner bottom to the neutral axis of the hull girder section

y_n = vertical distance, in m (ft), measured from the bottom to the neutral axis of the hull girder section

SM_{RB}, SM_B, R_b, Q_b and E are as defined in 3-4/7.3.1.

11.11 Side Frame

11.11.1 Side Frame

For floating liquefied gas terminals having topside tanks and bottom wing tanks with single side structure, the section modulus, SM_F , in cm³ (in³), is not to be less than that obtained from the following equation:

$$SM_F = 2.7sh_1\ell_f^2Q \quad \text{cm}^3$$

$$SM_F = 0.00143sh_1\ell_f^2Q \quad \text{in}^3$$

where

- s = frame spacing, in m (ft)
 $h_1 = 1.19 C_1 + P(d_s - h_p)$ m
 $= 3.9044 C_1 + P(d_s - h_p)$ ft
 $P = (d_B - d_s + 0.714C_1)/(d_B - d_s)$ m for $h_p \leq d_s$
 $= (d_B - d_s + 2.342C_1)/(d_B - d_s)$ ft for $h_p \leq d_s$
 $= 1.0$ for $h_p > d_s$
 d_s = draft amidships for full load condition, in m (ft)
 h_p = distance from base line to the mid-span of the side frame, in m (ft)
 d_B = bilge radius, in m (ft)
 C_1 = as defined in 3-3/5.1.1
 ℓ_f = unsupported span of frames, in m (ft), as shown in 3-4/Figure 6d
 Q = material conversion factor in 3-4/5.1 for the side frame under consideration

11.11.2 Frame Section

Frames are to be fabricated as symmetrical sections with integral upper and lower brackets. Their brackets are to be soft toed. The side frame flange is to be curved (not knuckled) at the transition to integral brackets. The radius of curvature is not to be less than r , in mm (in.), given by:

$$r = \frac{0.4b_f^2}{t_f}$$

Where b_f and t_f are the flange width and net flange thickness of the brackets, respectively, in mm (in.). The end of the flange is to be sniped.

The web depth to thickness ratio is to comply with the proportion limits given in 3-A2/11.9. The ratio of outstanding flange breadth to thickness is not to exceed $10/\sqrt{Q}$.

11.11.3 Section Modulus of Brackets

The net section modulus of the lower and upper brackets at the top of the lower wing tank and the bottom of the upper wing tank, as indicated in 3-4/Figure 6d, in association with the effective shell plating to which they are attached, is not to be less than obtained from the following equation:

$$SM_E = c_2 h_3^2 SM_F / (c_1 \ell_f^2) \text{ in cm}^3 \text{ (in}^3\text{)}$$

where

- $c_2 = 1.1$
 $h_3 =$ vertical distance, in m (ft), between the top of lower wing tank and the bottom of upper wing tank as shown in 3-4/Figure 6d
 $SM_F =$ required net section modulus of the side frame in 3-4/11.11.1
 $c_1 = 1 - 4(d/\ell_s) \geq 0.65$

Brackets are to be fitted in the lower and upper wing tanks in line with every side frame. These brackets are to be stiffened against buckling.

11.13 Web Stiffeners and Tripping Brackets

11.13.1 Web Stiffeners

In general, web stiffeners are to be fitted for the full depth of the webs of the main supporting member at every longitudinal.

Special attention is to be given to the stiffening of web plate panels close to change in contour of the web or where higher strength steel is used.

Web stiffener attachment to the deep webs, longitudinals, and stiffeners is to be effected by continuous welds.

Where depth/thickness ratio of the web plating exceeds 200, a stiffener is to be fitted parallel to the flange or face plate at approximately one-quarter depth of the web from the flange or face plate.

Alternative system of web-stiffening of the main supporting members may be considered based on the structural stability of the web and satisfactory levels of the shear stresses in the welds of the longitudinals to the web plates.

11.13.2 Tripping Bracket

Tripping brackets, arranged to support the flanges, are to be fitted at intervals of about 3 m (9.84 ft), close to any changes of section, and in line with the flanges of struts.

11.15 Slots and Lightening Holes

When slots and lightening holes are cut in transverses, webs, floors, stringers and girders, they are to be kept well clear of other openings. The slots are to be neatly cut and well rounded. Lightening holes are to be located midway between the slots and at about one-third of the depth of the web from the shell, deck or bulkhead. Their diameters and the depth of the slots for longitudinals are not to exceed one-third the depth of the web. In general, lightening holes are not to be cut in those areas of webs, floors, stringers, girders, and transverses where the shear stresses are high. Similarly, slots for longitudinals are to be provided with filler plates or other reinforcement in these same areas. Where it is necessary to cut openings in highly stressed areas, they are to be effectively compensated. Continuous fillet welds are to be provided at the connection of the filler plates to the web and at the connection of the filler plate to the longitudinals.

FIGURE 6
Definition of Parameters for Deck and Side Structure

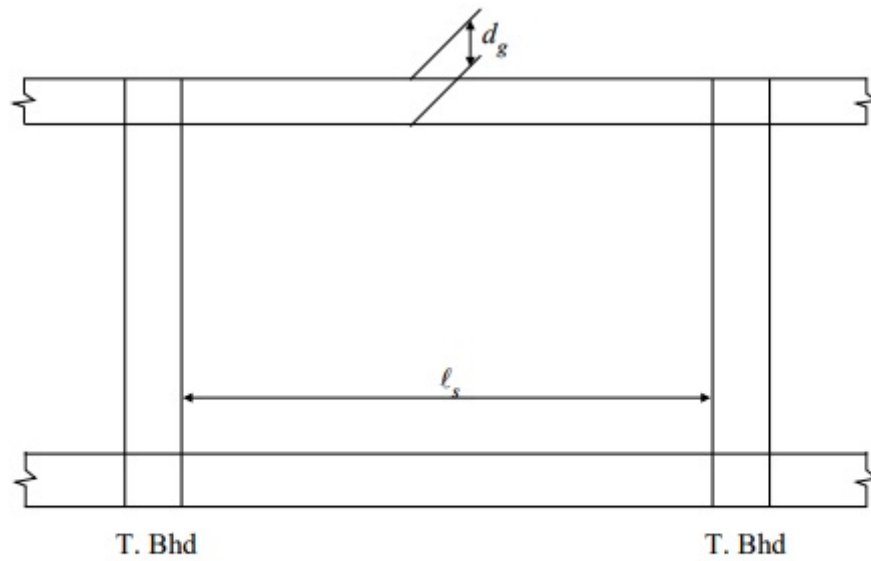

a) Longitudinal Cross-Section

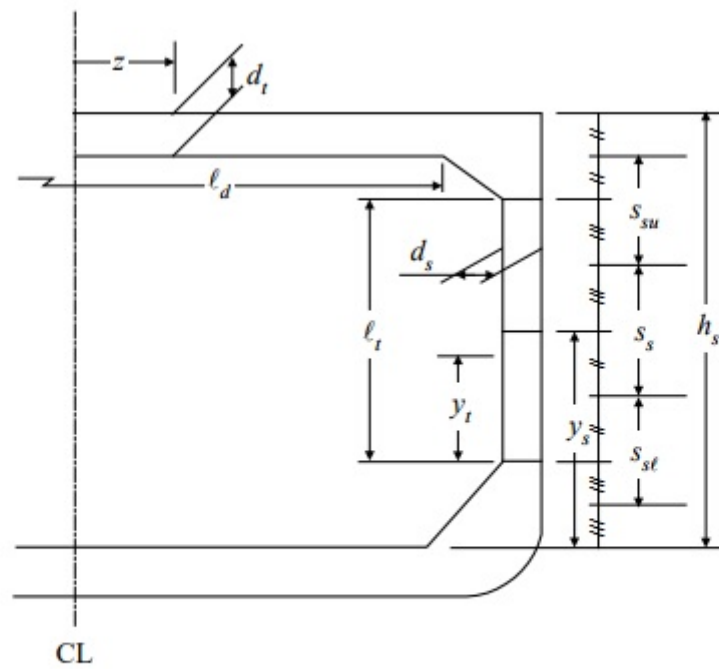

b) Single Centerline Tank Cross-Section

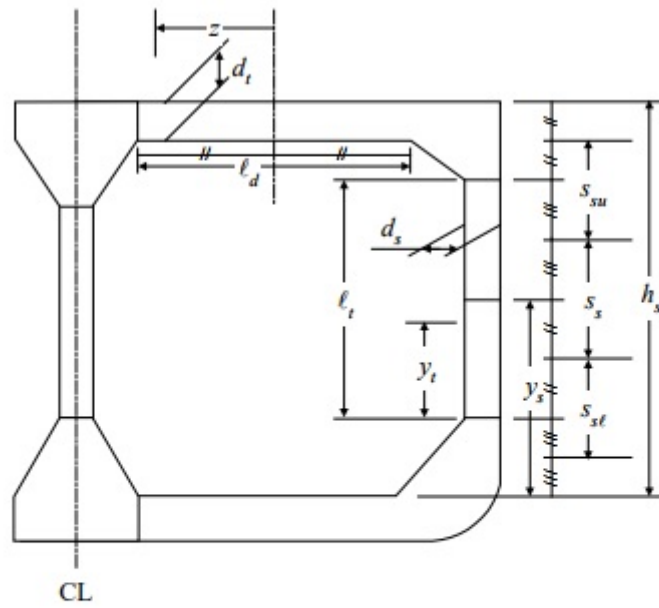

c) Two Tanks Abreast with CL Cofferdam Bulkhead

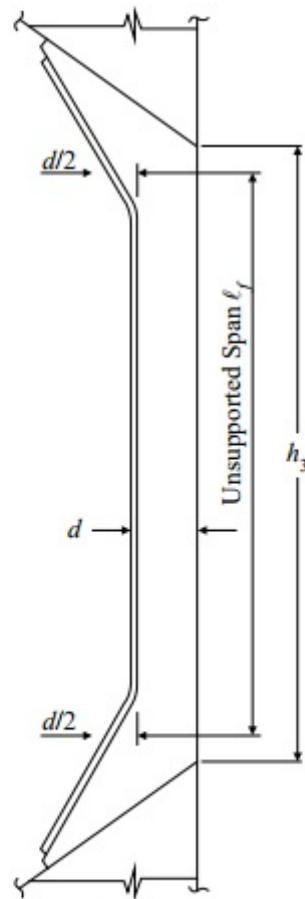

d) Side Frame

FIGURE 7
Effectiveness of Brackets

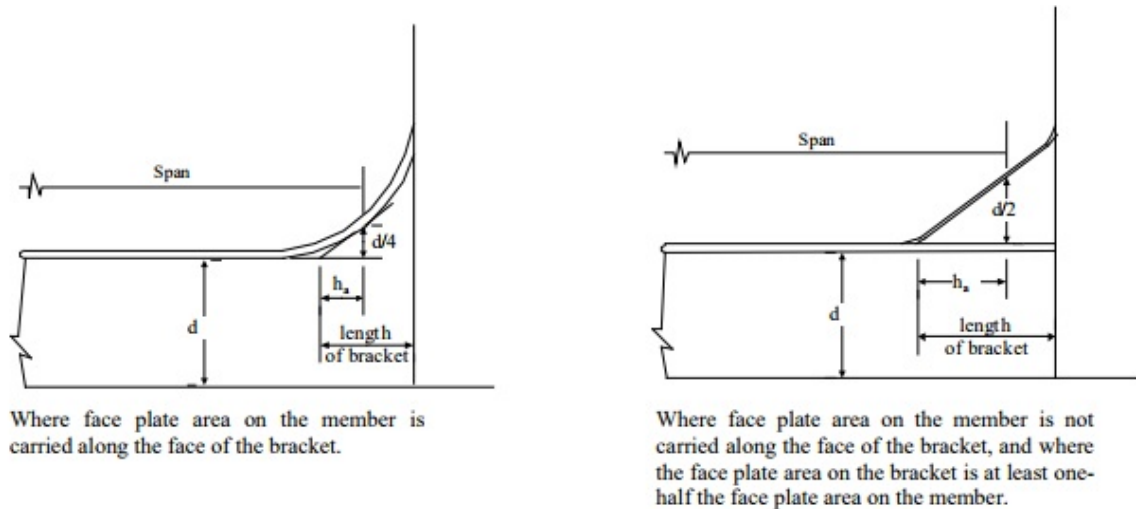

Brackets are not to be considered effective beyond the point where the arm of the girder or web is 1.5 times the arm on the bulkhead or base.

13 Longitudinal and Transverse Bulkheads

13.1 Longitudinal Bulkhead Plating

The net thickness of the longitudinal bulkhead plating, in addition to complying with 3-4/5.5, is to be not less than t_1 , t_2 , t_3 , nor t_4 , as specified below:

$$t_1 = 0.73s(k_1p/f_1)^{1/2} \text{ mm (in.)}$$

$$t_2 = 0.73sk(k_2p/f_2)^{1/2} \text{ mm (in.)}$$

$$t_3 = cs(S_m f_y/E)^{1/2} \text{ mm (in.)}$$

$$t_4 = 0.73sk(k_3p_{gc}/f)^{1/2} \text{ mm (in.)}$$

Where the inner skin bulkhead plating is transversely stiffened locally, the net thickness of the bulkhead plating is not to be less than t_5 or t_6 in lieu of t_1 , t_2 , t_3 and t_4 , as specified below:

$$t_5 = 0.73s_t k(k_2p/f_2)^{1/2} \text{ mm (in.)}$$

$$t_6 = 0.73s_t k(k_3p_{gc}/f)^{1/2} \text{ mm (in.)}$$

but not less than 9.5 mm (0.37 in.) where

s = spacing of longitudinal bulkhead longitudinals, in mm (in.)

s_t = spacing of transversely stiffened bracket, in mm (in.)

k_1 = 0.342

k_2 = 0.5

$$k_3 = 0.5$$

$$k = (3.075(\alpha)^{1/2} - 2.077)/(\alpha + 0.272) \quad (1 \leq \alpha \leq 2)$$

$$= 1.0 \quad (\alpha > 2)$$

α = aspect ratio of the panel (longer edge/shorter edge)

p = pressure at the lower edge of each plate, p_i , or maximum slosh pressure, p_s , whichever is greater, in N/cm² (kgf/cm², lbf/in²).

In no case is p to be taken less than 2.06 N/cm² (0.21 kgf/cm², 2.987 lbf/in²) for ballast tanks nor 2.50 N/cm² (0.255 kgf/cm², 3.626 lbf/in²) for cargo tanks.

$$p_i = p_n \quad \text{in cargo tanks, in N/cm}^2 \text{ (kgf/cm}^2 \text{, lbf/in}^2\text{)}$$

$$= p_n - p_{uo} \quad \text{in ballast tanks, in N/cm}^2 \text{ (kgf/cm}^2 \text{, lbf/in}^2\text{)}$$

p_n is nominal pressure, in N/cm² (kgf/cm², lbf/in²), at the lower edge of each plate, as defined in 3-3/Table 3 for longitudinal bulkhead plating.

p_{uo} is defined in 3-4/9.1.

The net thickness, t_3 , may be determined based on S_m and f_y of the hull girder strength material required at the location under consideration.

$$p_s = k_s p_{is}, \text{ not to be taken less than } k_s p_{is(mid)}$$

p_{is} = nominal slosh pressure, as specified in 3-3/11.5.1

$p_{is(mid)}$ = nominal slosh pressure at the mid-tank of the bulkhead at the same height at the point under consideration

$$k_s = 1.0$$

f_1 = permissible bending stress, in the longitudinal direction, in N/cm² (kgf/cm², lbf/in²)

$$= [1 - 0.28z/B - 0.52\alpha_1(SM_{RB}/SM_B)(y/y_n)]S_m f_y \quad \text{below neutral axis}$$

$$= [1 - 0.28z/B - 0.52\alpha_2(SM_{RD}/SM_D)(y/y_n)]S_m f_y \quad \text{above neutral axis}$$

$$\alpha_1 = S_{m1} f_{y1} / S_m f_y$$

$$\alpha_2 = S_{m2} f_{y2} / S_m f_y$$

S_m = strength reduction factor for the material of the longitudinal bulkhead plating obtained from 3-4/7.3.1

f_y = minimum specified yield point of the longitudinal bulkhead plating, in N/cm² (kgf/cm², lbf/in²)

z = transverse distance, in m (ft), measured from the centerline of the section to the bulkhead strake under consideration

y_n = vertical distance, in m (ft), measured from the deck (bottom) to the neutral axis of the section, when the strake under consideration is above (below) the neutral axis.

f_2 = permissible bending stress, in the vertical direction, in N/cm² (kgf/cm², lbf/in²)

$$= 0.85 S_m f_y$$

$$c = 0.7N^2 - 0.2$$

c for the top strake is not to be taken less than $0.4Q^{1/2}$, but need not be greater than 0.45.
 c for other strakes is not to be taken less than 0.33, but need not be greater than $0.45(Q/Q_d)^{1/2}$ for the strake above the neutral axis nor $0.45(Q/Q_b)^{1/2}$ for the strake below the neutral axis.

- N = $R_d [(Q/Q_d)(y/y_n)]^{1/2}$ for strake above the neutral axis
 = $R_b[(Q/Q_b)(y/y_n)]^{1/2}$ for strake below the neutral axis
- y = vertical distance, in m (ft), measured from the neutral axis of the hull girder transverse section to the upper edge (lower edge) of the bulkhead strake, when the strake under consideration is above (below) the neutral axis for N
 = vertical distance, in m (ft), measured from the neutral axis of the hull girder transverse section to the lower edge of the bulkhead strake under consideration for f_1 .
- Q = material conversion factor in 3-4/5.1 for the longitudinal bulkhead plating
- B = breadth of vessel, in m (ft), as defined in 3-1-1/5 of the *Marine Vessel Rules*.
- p_{gc} = $p_o + (p_{gd})_{max}$ N/cm² (kgf/cm², lbf/in²)
- p_o = cargo tank design vapor pressure in N/cm² (kgf/cm², lbf/in²), as defined in 3-1/3.11
- p_{gd} = $a_\beta Z_\beta k_3 \rho 10^{-4}$ N/cm² (kgf/cm², lbf/in²)
- a_β = dimensionless acceleration, see 3-3/5.9.2
- Z_β = largest cargo tank liquid head, in m (ft), above the point on the inner skin bulkhead plates under consideration, see 3-3/5.9.2
- k_3 = 9.81(1.0, 69.44)
- ρ = maximum cargo density, in N/m³ (kgf/m³, lbf/ft³), at the design temperature, but ρ is not to be taken less than 4900 N/m³ (500 kgf/m³, 31.214 lbf/ft³)
- f = permissible bending stress, in N/cm² (kgf/cm², lbf/in²)
 = $0.75f_y$

SM_{RB}, SM_B, R_b, Q_b and E are as defined in 3-4/7.3.1.

S_{m1} and f_{y1} are as defined in 3-4/7.5.

R_d and Q_d are as defined in 3-4/9.1.

SM_{RD}, SM_D, S_{m2} and f_{y2} are as defined in 3-4/9.5.

13.3 Transverse Bulkhead Plating

The net thickness of transverse bulkhead plating is to be not less than t as specified below:

$$t = 0.73sk(k_2p/f_2)^{1/2} \text{ mm (in.) but not less than 9.5 mm (0.37 in.)}$$

where

- s = spacing of transverse bulkhead stiffeners, in mm (in.)
 k_2 = 0.50

$$k = (3.075(\alpha)^{1/2} - 2.077)/(\alpha + 0.272) \quad (1 \leq \alpha \leq 2)$$

$$= 1.0 \quad (\alpha > 2)$$

α = aspect ratio of the panel (longer edge/shorter edge)

p = p_i or maximum slosh pressure, p_s , whichever is greater, in N/cm² (kgf/cm², lbf/in²)

In no case is p to be taken less than 2.06 N/cm² (0.21 kgf/cm², 2.987 lbf/in²) for ballast tanks nor 2.50 N/cm² (0.255 kgf/cm², 3.626 lbf/in²) for cargo tanks.

$$p_i = p_n \quad \text{in cargo tanks, in N/cm}^2 \text{ (kgf/cm}^2 \text{, lbf/in}^2\text{)}$$

$$= p_n - p_{uh} \quad \text{in ballast tanks, in N/cm}^2 \text{ (kgf/cm}^2 \text{, lbf/in}^2\text{)}$$

p_n is nominal pressure, in N/cm² (kgf/cm², lbf/in²), at the lower edge of each plate, as defined in 3-3/Table 3 for transverse bulkhead plating.

p_{uh} is defined in 3-4/7.3.1.

$$p_s = k_s p_{is}, \text{ not to be taken less than } k_s p_{is(mid)}$$

$$p_{is} = \text{nominal slosh pressure, as specified in 3-3/11.5.1}$$

$$p_{is(mid)} = \text{nominal slosh pressure at the centerline of the bulkhead at the same height as the point under consideration.}$$

$$k_s = 1.0$$

$$f_2 = \text{permissible bending stress, in N/cm}^2 \text{ (kgf/cm}^2 \text{, lbf/in}^2\text{)}$$

$$= 0.85 S_m f_y$$

S_m and f_y are as defined in 3-4/7.3.1.

The net thickness of transverse bulkhead plating in the center tank, outboard of 0.3B from the centerline of the tank, is also to be not less than as obtained from the above equation with the following substituted for p and f_2 :

$$p = \text{nominal pressure, in N/cm}^2 \text{ (kgf/cm}^2 \text{, lbf/in}^2\text{) as specified for inner skin longitudinal bulkhead structure (item 6 case a) in 3-3/Table 3, at the lower edge level of each transverse bulkhead plate.}$$

$$f_2 = S_m f_y, \text{ in N/cm}^2 \text{ (kgf/cm}^2 \text{, lbf/in}^2\text{)}$$

In addition to the above requirements, the net thickness of the transverse bulkhead plating in the cargo tank is not to be less than t as specified below:

$$t = 0.73sk(k_2 p_{gc}/f)^{1/2} \text{ mm (in.)}$$

where

$$s = \text{spacing of stiffeners, in mm (in.)}$$

$$k_2 = 0.50$$

$$p_{gc} = p_o + (p_{gd})_{max} \text{ N/cm}^2 \text{ (kgf/cm}^2 \text{, lbf/in}^2\text{)}$$

- p_o = cargo tank design vapor pressure in N/cm^2 (kgf/cm^2 , lbf/in^2), as defined in 3-1/3.11
- p_{gd} = $a_\beta Z_\beta k_3 \rho 10^{-4}$ N/cm^2 (kgf/cm^2 , lbf/in^2)
- a_β = dimensionless acceleration, see 3-3/5.9.2
- Z_β = largest cargo tank liquid head in m (ft) above the point on the transverse bulkhead plates under consideration, see 3-3/5.9.2
- k_3 = 9.81(1.0, 69.44)
- ρ = maximum cargo density, in N/m^3 (kgf/m^3 , lbf/ft^3), at the design temperature, but ρ is not to be taken less than 4900 N/m^3 (500 kgf/m^3 , 31.214 lbf/ft^3)
- f = permissible bending stress, in N/cm^2 (kgf/cm^2 , lbf/in^2)
 = $0.75f_y$

All other parameters are as defined above.

13.5 Longitudinals and Vertical/Horizontal Stiffeners

The net section modulus of each individual longitudinal or vertical/horizontal stiffener on inner skin and transverse bulkheads, in association with the effective plating to which it is attached, is to be not less than obtained from the following equation:

$$SM_2 = M/f_b \text{ cm}^3 (\text{in}^3)$$

$$M = 1000c_1 p s \ell^2 / k \text{ N-cm (kgf-cm, lbf-in)}$$

where

- k = 12 (12, 83.33)
- c_1 = 1.0 for longitudinals and horizontal stiffeners
 = $1 + \gamma \ell / 10p$ for vertical stiffeners
- γ = specific weight of the liquid, not to be taken less than $0.49 \text{ N/cm}^2\text{-m}$ ($0.05 \text{ kgf/cm}^2\text{-m}$, $0.2168 \text{ lbf/in}^2\text{-ft}$) for liquid cargo and than $1.005 \text{ N/cm}^2\text{-m}$ ($0.1025 \text{ kgf/cm}^2\text{-m}$, $0.4444 \text{ lbf/in}^2\text{-ft}$) for ballast water
- s = spacing of longitudinals or vertical/horizontal stiffeners, in mm (in.)
- ℓ = span of longitudinals or stiffeners between effective supports, in m (ft)
- p = pressure, p_p , in N/cm^2 (kgf/cm^2 , lbf/in^2), at the longitudinal or stiffener considered, as specified in 3-4/13.1 and 3-4/13.3, or maximum slosh pressure, p_s , whichever is greater. For vertical stiffeners, pressure is to be taken at the middle of span of each stiffener.
- p_s = $c_3 p_{is}$ not to be taken less than $c_3 p_{is(mid)}$
- $p_{is(mid)}$ = nominal slosh pressure at the mid-tank of the bulkhead at the same height as the point under consideration
- p_{is} = nominal slosh pressure, as specified in 3-3/11.5.1
- c_3 = 1.0
- f_b = permissible bending stresses, in N/cm^2 (kgf/cm^2 , lbf/in^2).
 = $0.70S_m f_y$ for transverse bulkhead stiffeners

$$= 1.4[1.0 - 0.28(z/B) - 0.52\alpha_1(SM_{RB}/SM_B)(y/y_n)]S_m f_y \leq 0.90S_m f_y \quad \text{for longitudinal of inner skin bulkhead below neutral axis}$$

$$= 2.2[1.0 - 0.28(z/B) - 0.52\alpha_2(SM_{RD}/SM_D)(y/y_n)]S_m f_b \leq 0.90S_m f_y \quad \text{for longitudinal of inner skin bulkhead above neutral axis}$$

z = transverse distance, in m (ft), measured from the centerline of the vessel to the longitudinal under consideration at its connection to the associated plate

B = breadth of vessel, in m (ft), as defined in 3-1-1/5 of the *Marine Vessel Rules*

$S_m f_y$ and α_1 are as defined in 3-4/7.5.

$\alpha_2, y, y_n, SM_{RD}$ and SM_D are as defined in 3-4/9.5.

SM_{RB} and SM_B are as defined in 3-4/7.3.1.

The effective breadth of plating, b_e , is as defined in line b) of 3-4/Figure 4.

The net section modulus of transverse bulkhead stiffeners in the center tank, located outboard of $0.3B$ from the centerline of the tank, is also to be not less than as obtained from the above equation with the following substituted for p and f_2 :

p = nominal pressure, in N/cm^2 (kgf/cm^2 , lbf/in^2), as specified for inner skin longitudinal bulkhead structure (item 6 case “a”) in 3-3/Table 3 at each transverse bulkhead stiffener level.

f_b = $S_m f_y$, in N/cm^2 (kgf/cm^2 , lbf/in^2)

In addition, each longitudinal or stiffener is also to have a section modulus not less than obtained from the following equations:

$$SM_2 = c_{gc} K_1 M f_b \text{ cm}^3 \text{ (in}^3\text{)}$$

$$M = 1000 p_{gc} s \ell^2 / k \text{ N-cm (kgf-cm, lbf-in)}$$

where

k = 12 (12, 83.33)

s = spacing of longitudinal/stiffener, in mm (in.)

ℓ = span of the longitudinal or stiffener between effective supports, as shown in 3-4/Figure 3, in m (ft)

c_{gc} = adjustment factor for corrosion of longitudinals/stiffeners in tanks

= 0.90

= adjustment factor for corrosion of longitudinals/stiffeners in void spaces

= 0.94

K_1	=	0.9
p_{gc}	=	$p_o + (p_{gd})_{max}$ N/cm ² (kgf/cm ² , lbf/in ²)
p_o	=	cargo tank design vapor pressure, in N/cm ² (kgf/cm ² , lbf/in ²), as defined in 3-1/3.11
p_{gd}	=	$a_\beta Z_\beta k_3 \rho 10^{-4}$ N/cm ² (kgf/cm ² , lbf/in ²)
a_β	=	dimensionless acceleration, see 3-3/5.9.2
Z_β	=	largest cargo tank liquid head in m (ft) above the point on the bulkhead longitudinal or stiffener under consideration, see 3-3/5.9.2
k_3	=	9.81(1.0, 69.44)
ρ	=	maximum cargo density, in N/m ³ (kgf/m ³ , lbf/ft ³), at the design temperature, but ρ is not to be taken less than 4900 N/m ³ (500 kgf/m ³ , 31.214 lbf/ft ³)
f_b	=	permissible bending stresses, in N/cm ² (kgf/cm ² , lbf/in ²)
	=	$S_{gc} f_y$
S_{gc}	=	0.64 for ordinary strength steel
	=	0.53 for H32 strength steel
	=	0.52 for H36 strength steel

The net moment of inertia of longitudinals on the inner skin bulkhead, with the associated effective plating, within the region of 0.1Ds from the upper deck is to be not less than i_o , as specified in 3-4/9.7 of this Guide.

13.7 Longitudinal Stool Plating (1 September 2012)

The net thickness of the longitudinal stool plating is to be not less than t_1, t_2, t_3 as specified below:

$$t_1 = 0.73s(k_1 p / f_1)^{1/2} \text{ mm (in.)}$$

$$t_2 = 0.73s(k_2 p / f_2)^{1/2} \text{ mm (in.)}$$

$$t_3 = cs(S_m f_y / E)^{1/2} \text{ mm (in.)}$$

but not less than 9.5 mm (0.37 in.) where

s = spacing of longitudinals on stool plating, in mm (in.)

k_1 = 0.342

k_2 = 0.5

k = $(3.075(\alpha)^{1/2} - 2.077) / (\alpha + 0.272)$ ($1 \leq \alpha \leq 2$)

= 1.0 ($\alpha > 2$)

α = aspect ratio of the panel (longer edge/shorter edge)

p = pressure at the lower edge of each plate, p_i , in N/cm² (kgf/cm², lbf/in²).

p_n is nominal pressure, in N/cm² (kgf/cm², lbf/in²), on stool plating as defined in 3-3/Table 3 for longitudinal stool plating.

The net thickness, t_3 , may be determined based on S_m and f_y of the hull girder strength material required at the location under consideration.

f_1 = permissible bending stress, in the longitudinal direction, in N/cm² (kgf/cm², lbf/in²)

$$= [1 - 0.52\alpha_1(SM_{RB}/SM_B)(y/y_n)]S_m f_y \quad \text{below neutral axis}$$

$$= [1 - 0.52\alpha_2(SM_{RD}/SM_D)(y/y_n)]S_m f_y \quad \text{above neutral axis}$$

$$\alpha_1 = S_{m1}f_{y1}/S_m f_y$$

$$\alpha_2 = S_{m2}f_{y2}/S_m f_y$$

S_m = strength reduction factor for the material of the longitudinal stool plating obtained from 3-4/7.3.1

f_y = minimum specified yield point of the longitudinal stool plating, in N/cm² (kgf/cm², lbf/in²)

y_n = vertical distance, in m (ft), measured from the deck (bottom) to the neutral axis of the section, when the stool plating under consideration is above (below) the neutral axis.

f_2 = permissible bending stress, in the vertical direction, in N/cm² (kgf/cm², lbf/in²)

$$= 0.85S_m f_y$$

c = $0.7N^2 - 0.2$, not to be taken less than $0.3Q^{1/2}$.

N = $R_d[(Q/Q_d)(y/y_n)]^{1/2}$ for plate above the neutral axis

$$= R_b[(Q/Q_b)(y/y_n)]^{1/2} \quad \text{for plate below the neutral axis}$$

y = vertical distance, in m (ft), measured from the neutral axis of the hull girder section to the longitudinal stool plating under consideration

Q = material conversion factor in 3-4/5.1 for the longitudinal stool plating

SM_{RB}, SM_B, R_b, Q_b and E are as defined in 3-4/7.3.1.

S_{m1} and f_{y1} are as defined in 3-4/7.5.

R_d and Q_d are as defined in 3-4/9.1.

SM_{RD}, SM_D, S_{m2} and f_{y2} are as defined in 3-4/9.5.

13.9 Longitudinal Stiffeners on Longitudinal Stool Plate (1 September 2012)

The net section modulus of each individual longitudinal stiffener on longitudinal stool plating, in association with the effective plating to which it is attached, is to be not less than obtained from the following equation:

$$SM_2 = M/f_b \text{ cm}^3 \text{ (in}^3\text{)}$$

$$M = 1000c_1ps\ell^2/k \text{ N-cm (kgf-cm, lbf-in)}$$

where

$$k = 12 \text{ (12, 83.33)}$$

$$c_1 = 1.0$$

- s = spacing of longitudinals or vertical/horizontal stiffeners, in mm (in.)
 = span of longitudinals or stiffeners between effective supports, in m (ft)
- p = pressure, p_p , in N/cm² (kgf/cm², lbf/in²), at the longitudinal or stiffener considered, as specified in 3-4/13.1 and 3-4/13.3.
- f_b = permissible bending stresses, in N/cm² (kgf/cm², lbf/in²).
 = $1.4[1.0 - 0.52\alpha_1(SM_{RB}/SM_B)(y/y_n)]S_m f_y \leq 0.90S_m f_y$ for longitudinals below neutral axis
 = $2.2[1.0 - 0.52\alpha_2(SM_{RD}/SM_D)(y/y_n)]S_m f_y \leq 0.90S_m f_y$ for longitudinals above neutral axis
- z = transverse distance, in m (ft), measured from the centerline of the vessel to the longitudinal under consideration at its connection to the associated plate
- B = breadth of vessel, in m (ft), as defined in 3-1-1/5 of the *Marine Vessel Rules*

$S_m f_y$ and α_1 are as defined in 3-4/7.5.

$\alpha_2, y, y_n, SM_{RD}$ and SM_D are as defined in 3-4/9.5.

SM_{RB} and SM_B are as defined in 3-4/7.3.1.

The effective breadth of plating, b_e , is as defined in line b) of 3-4/Figure 4.

15 Transverse Bulkheads - Main Supporting Members

15.1 General

The main supporting members of transverse cofferdam bulkheads are to be arranged and designed as indicated in 3-4/11.1.

In general, the width of a transverse cofferdam is to be not less than 90 mm/m (1.08 in./ft) of the lesser of the breadth, b , or the depth, h , of the tank as shown in 3-4/Figure 8 and is to be of sufficient width to provide ready access.

15.3 Vertical Webs (2018)

The net thickness of the vertical webs is to be not less than t_1 as defined below:

$$t_1 = F_1 / (k_1 d_v f_s) \text{ mm (in.)} \quad \text{but not to be less than 11.0 mm (0.433 in.)}$$

where

F_1 = shear force in the vertical web, as obtained from the equation given below. The required scantling t_1 may be reduced to 85%, but not to be less than 11.0 mm (0.433 in.), provided the strength is verified in the total strength assessment:

$$= 750k_2\eta_1\gamma_1\beta_1p\ell_v s_v \text{ N (kgf, lbf)}$$

$$k_1 = 10.0 (10.0, 12.0)$$

$$k_2 = 1.0 (1.0, 2.24)$$

$$\eta_1 = 1 - (b_\ell h_\ell + b_u h_u) / bh \quad \text{for one tank abreast}$$

$$= 1 - (b_\ell + b_u) / b \quad \text{for two tanks abreast}$$

$$\gamma_1 = 1.0 - 2.5(y_v / \ell_v) \quad 0.5 \leq \gamma_1 \leq 1.0$$

$$\beta_1 = \text{for one tank abreast}$$

$$= 1.0 \quad \text{for } z_v / b \leq 0.15$$

$$= 1.2(1 - z_v / b) \geq 0.65, \text{ need not be greater than } 1.0 \quad \text{for } z_v / b > 0.15$$

$$= \text{for two tanks abreast}$$

$$= 0.65$$

b = breadth of the tank in m (ft), as defined in 3-4/Figure 8

h = depth of the tank in m (ft), as defined in 3-4/Figure 8

b_ℓ = width of the lower sloping bulkhead in m (ft), as defined in 3-4/Figure 8

h_ℓ = height of the lower sloping bulkhead in m (ft), as defined in 3-4/Figure 8

b_u = width of the upper sloping bulkhead in m (ft), as defined in 3-4/Figure 8

h_u = height of the upper sloping bulkhead in m (ft), as defined in 3-4/Figure 8

d_v = actual depth of the vertical web, in m (ft)

p = nominal pressure at the mid-depth of the tank at the tank's centerline, in kN/m² (tf/m², Ltf/ft²), as specified in 3-3/Table 3.

ℓ_v = span of the vertical web under consideration, in m (ft), as shown in 3-4/Figure 8

y_v = distance from the inner bottom to the location of the vertical web under consideration, in m (ft), as shown in 3-4/Figure 8

z_v = distance from the tank's centerline to the location of the vertical web under consideration, in m (ft), as shown in 3-4/Figure 8

s_v = spacing of the vertical web under consideration, in m (ft), as shown in 3-4/Figure 8

f_s = permissible shear stresses, in N/cm² (kgf/cm², lbf/in²)

$$= 0.45 S_m f_y$$

f_y = minimum specified yield point of the material for the vertical web, in N/cm² (kgf/cm², lbf/in²)

S_m = strength reduction factor

$$= 1.0 \quad \text{for ordinary strength steel}$$

$$= 0.95 \quad \text{for H32 strength steel}$$

$$= 0.908 \quad \text{for H36 strength steel}$$

$$= 0.875 \quad \text{for H40 strength steel}$$

In addition to the above requirement, the net thickness of the vertical webs is to be not less than t_2 as specified below:

$$t_2 = F_2 / (k_4 d_c f_s) \text{ mm (in.) but not to be less than 11.0 mm (0.433 in.)}$$

where

F_2 = shear force in the vertical web, as obtained from finite element analyses, as specified in 3-5/9 with the additional IGC load cases in 3-5/9.7

k_4 = 10.0 (10.0, 64.3)

p_{gc} = $p_o + (p_{gd})_{max}$ N/cm² (kgf/cm², lbf/in²)

p_o = cargo tank design vapor pressure in N/cm² (kgf/cm², lbf/in²), as defined in 3-1/3.11

p_{gd} = $a_\beta Z_\beta k_3 \rho 10^{-4}$ N/cm² (kgf/cm², lbf/in²)

a_β = dimensionless acceleration, see 3-3/5.9.2

Z_β = largest cargo tank liquid head in m (ft) above the point at the mid-depth of the tank at the tank's centerline on the transverse bulkhead, see 3-3/5.9.2

k_3 = 9.81 (1.0, 69.44)

ρ = maximum cargo density, in N/m³ (kgf/m³, lbf/ft³), at the design temperature, but ρ is not to be taken less than 4900 N/m³ (500 kgf/m³, 31.214 lbf/ft³)

f_s = permissible shear stresses, in N/cm² (kgf/cm², lbf/in²)
 = $0.5 f_y$

All other parameters are also defined as above.

15.5 Horizontal Web

15.5.1 Fully Extended Horizontal Webs (2018)

The net thickness of the horizontal webs which fully extend from side to side is to be not less than t_1 as defined below:

$$t_1 = F_1 / (k_1 d_h f_s) \text{ mm (in.) but not to be less than 9.5 mm (0.374 in.)}$$

where

F_1 = shear force in the horizontal web, as obtained from the equation given below. The required scantling t_1 may be reduced to 85%, but not to be less than 9.5 mm (0.374 in.), provided the strength is verified in the total strength assessment:

$$= 585 k_2 \eta_2 \gamma_2 \beta_2 c_u c_1 p_h s_h \alpha \text{ N (kgf, lbf)}$$

k_1 = 10.0 (10.0, 12.0)

k_2 = 1.0 (1.0, 2.24)

d_h = actual depth of the horizontal web, in m (ft)

η_2 = $1 - (h + h_u) / h$

- $\gamma_2 = -0.5 + 5(y_h/h) \geq 0.55$ for $y_h/h \leq 0.3$
 $= 1$ for $0.3 < y_h/h < 0.5$
 $= 2 - 2(y_h/h) \geq 0.60$ for $y_h/h \geq 0.5$
- $\beta_2 = 2z_h/b \geq 0.4$
- $c_u = 1 + 1.5(1 - y_u/h_u)^2$ for uppermost horizontal web
 $= 1.0$ for other horizontal webs
- $y_u =$ distance from the inner deck to the uppermost horizontal web, in m (ft), as shown in 3-4/Figure 8
- $c_1 =$ adjustment factor for fitting of effective partial webs as defined in 3-4/15.5.2
 $= 1/\{1 + c_2(t_p/t_h) [1 - (y_p/s_1)^{0.5}]^{1.25}\}$ where effective partial webs are fitted on above and below the horizontal web under consideration, c_1 may be obtained by multiplying that for each partial web.
 $= 1.0$ where an effective partial web is not fitted
- $c_2 = 2(z_h - z_p)/d_h$ $0 \leq c_2 \leq 1.0$
- $z_h =$ distance from the tank's centerline to the location of the horizontal web under consideration, in m (ft), as shown in 3-4/Figure 8
- $z_p =$ distance from the tank's centerline to the inboard end of the effective partial web, in m (ft), as shown in 3-4/Figure 8
- $t_p =$ actual net thickness of an effective partial web at the location under consideration, in mm (in.)
- $t_h =$ actual net thickness of the horizontal web at the location under consideration, in mm (in.)
- $y_p =$ distance from the effective partial web to the horizontal web under consideration, in m (ft), as shown in 3-4/Figure 8
- $s_1 =$ distance between the fully extended horizontal webs where the effective partial web is located, in m (ft), as shown in 3-4/Figure 8
- $p =$ nominal pressure at the mid-depth of the tank at the tank's centerline, in kN/m² (tf/m², Ltf/ft²), as specified in 3-3/Table 3.
- $\ell_h =$ span of the horizontal web under consideration, in m (ft), as shown in 3-4/Figure 8
- $y_h =$ distance from the inner bottom to the location of the horizontal web under consideration, in m (ft), as shown in 3-4/Figure 8
- $s_h =$ sum of one-half of fully extended horizontal web spacing of the horizontal web under consideration, in m (ft), as shown in 3-4/Figure 8
- For the horizontal web located between h_l above the inner bottom and h_u below the inner deck, s_h need not be taken greater than $(h - h - h_u)/2$
- For the horizontal webs in way of slanted longitudinal bulkhead or inner deck plating, suitable adjustment may be made for the reduced area supported by the horizontal webs.
- $\alpha = 0.95(h/b) + 0.01$

$$f_s = \text{permissible shear stresses, in N/cm}^2 \text{ (kgf/cm}^2 \text{, lbf/in}^2\text{)}$$

$$= 0.45 S_m f_y$$

b, h, b_w, h_w, f_y and S_m are defined in 3-4/15.3 above.

In addition to the above requirement, the net thickness of the horizontal webs is to be not less than t_2 as specified below:

$$t_2 = F_2 / (k_4 d_h f_s) \text{ mm (in.) but not to be less than 9.5 mm (0.374 in.)}$$

where

$$F_2 = \text{shear force in the horizontal web, as obtained from finite element analyses, as specified in 3-5/9 with the additional IGC load cases in 3-5/9.7}$$

$$k_4 = 10.0 \text{ (10.0, 64.3)}$$

$$p_{gc} = p_o + (p_{gd})_{max} \text{ N/cm}^2 \text{ (kgf/cm}^2 \text{, lbf/in}^2\text{)}$$

$$p_o = \text{cargo tank design vapor pressure, in N/cm}^2 \text{ (kgf/cm}^2 \text{, lbf/in}^2\text{), as defined in 3-1/3.11}$$

$$p_{gd} = a_\beta Z_\beta k_3 \rho 10^{-4} \text{ N/cm}^2 \text{ (kgf/cm}^2 \text{, lbf/in}^2\text{)}$$

$$a_\beta = \text{dimensionless acceleration, see 3-3/5.9.2}$$

$$Z_\beta = \text{largest cargo tank liquid head, in m (ft), above the at the mid-depth of the tank at the tank's centerline on the transverse bulkhead, see 3-3/5.9.2}$$

$$k_3 = 9.81 \text{ (1.0, 69.44)}$$

$$\rho = \text{maximum cargo density, in N/m}^3 \text{ (kgf/m}^3 \text{, lbf/ft}^3\text{), at the design temperature, but } \rho \text{ is not to be taken less than 4900 N/m}^3 \text{ (500 kgf/m}^3 \text{, 31.214 lbf/ft}^3\text{)}$$

$$f_s = \text{permissible shear stresses, in N/cm}^2 \text{ (kgf/cm}^2 \text{, lbf/in}^2\text{)}$$

$$= 0.5 f_y$$

$$k = 1.0 \text{ (1.0, 0.269)}$$

All other parameters are also defined as above.

15.5.2 Effective Partial Webs

Where a partial horizontal web is fitted between h_p above the inner bottom and h_u below the inner deck and is extended to at least two vertical webs from the inner skin bulkhead on each side, the partial horizontal web may be considered effective in the scantling determination of the fully extended horizontal web in 3-4/15.5.1 and the net thickness of the partial horizontal web is to be not less than t_1 as defined below:

$$t_1 = F_1 / (k_1 d_h f_s) \text{ mm (in.) but not to be less than 9.5 mm (0.374 in.)}$$

where

$$F_1 = \text{shear force in the partial horizontal web, as obtained from the equation given below. The required scantling } t_1 \text{ may be reduced to 85\%, but not to be less than 9.5 mm (0.374 in.), provided the strength is verified in the total strength assessment:}$$

$$= 293 k_2 a \eta_2 \beta_2 p b s_1 \alpha \text{ N (kgf, lbf)}$$

$$d_h = \text{actual depth of the partial horizontal web, in m (ft)}$$

$$f_s = \text{permissible shear stresses, in N/cm}^2 \text{ (kgf/cm}^2 \text{, lbf/in}^2)$$

$$= 0.45S_m f_y$$

All other parameters are defined in 3-4/15.5.1 above.

In addition to the above requirement, the net thickness of the partial webs is to be not less than t_2 as specified below:

$$t_2 = F_2 / (k_4 d_h f_s) \text{ mm (in.) but not to be less than 9.5 mm (0.374 in.)}$$

where

$$F_2 = \text{shear force in the partial horizontal web, as obtained from finite element analyses, as specified in 3-5/9 with the additional IGC load cases in 3-5/9.7}$$

$$k_4 = 10.0 \text{ (10.0, 64.3)}$$

$$f_s = \text{permissible shear stresses, in N/cm}^2 \text{ (kgf/cm}^2 \text{, lbf/in}^2)$$

$$= 0.5f_y$$

All other parameters are defined above and in 3-4/15.5.1.

15.5.3 Other Partial Webs

The net thickness of the partial horizontal webs other than in 3-4/15.5.2 is to be not less than t_1 nor t_2 as specified in 3-4/15.5.2 using F_1 and F_2 as obtained from the following:

$$F_1 = \text{shear force in the partial horizontal web, as obtained from the equation given below. The required scantling } t_1 \text{ may be reduced to 85\%, but not less than } t_1 \text{ nor } t_2 \text{ as specified in 3-4/15.5.2, provided the strength is verified in the total strength assessment:}$$

$$= 293k_2\eta_2\gamma_3\beta_2pb_p s_1\alpha \text{ N (kgf, lbf)}$$

$$F_2 = \text{shear force in the partial horizontal web, as obtained from finite element analyses, as specified in 3-5/9 with the additional IGC load cases in 3-5/9.7}$$

where

$$k_4 = 10.0 \text{ (10.0, 64.3)}$$

$$\gamma_3 = 0.5 \quad \text{for a partial horizontal web as extended to one vertical web from the tank boundary bulkhead on each side}$$

$$= 1.0 \quad \text{for a partial horizontal web as extended to at least two vertical webs from the tank boundary bulkhead on each side}$$

$$b_p = \text{breadth of the tank at the partial web under consideration in m (ft), as defined in 3-4/ Figure 8}$$

All other parameters are defined above.

15.7 Stiffeners, Tripping Brackets, Slots and Lightning Holes

Requirements for these items are given in 3-4/11.13 and 3-4/11.15.

FIGURE 8
Transverse Bulkhead Structures

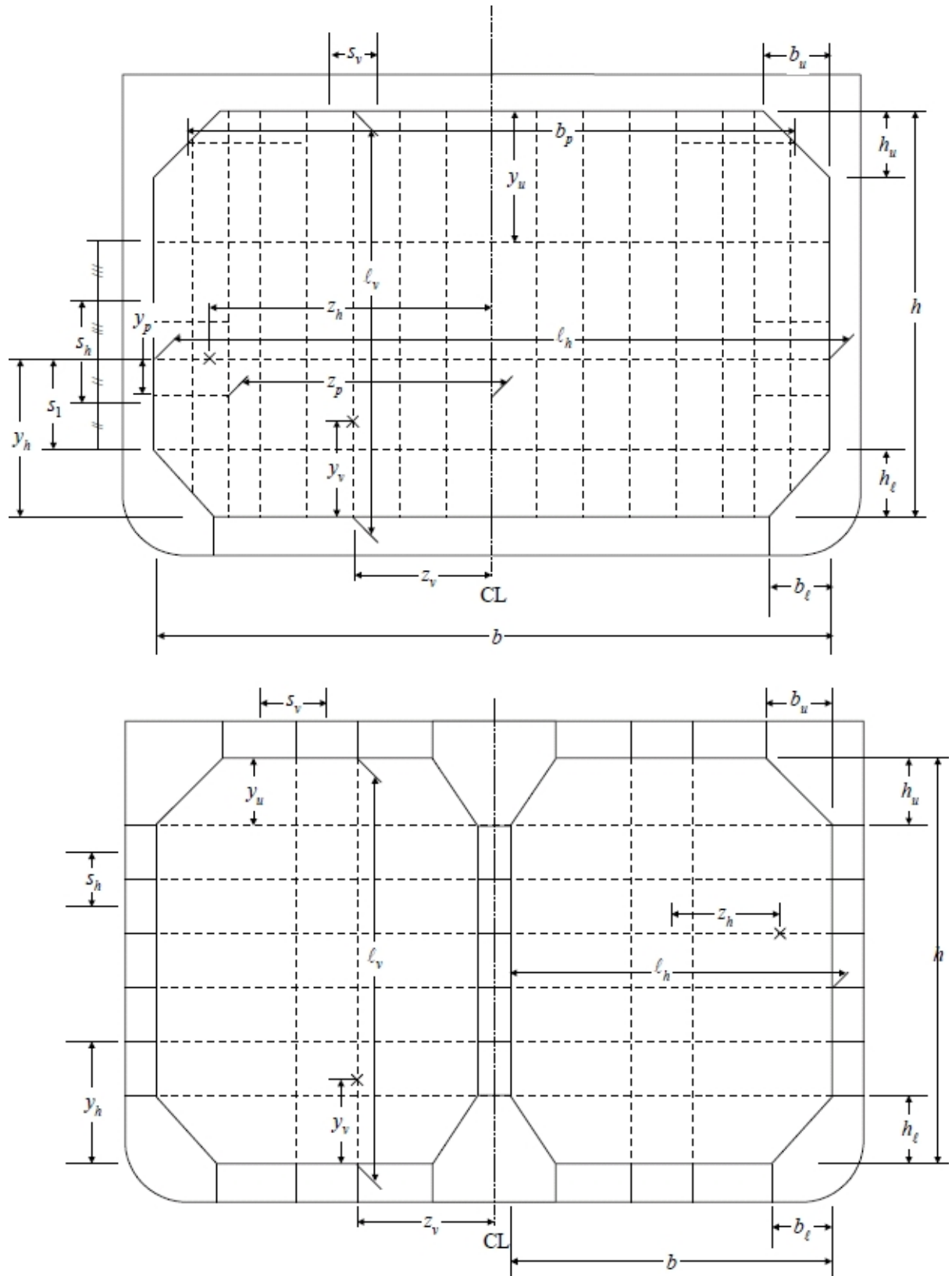

17 Independent Cargo Tank Structures

17.1 General (1 September 2012)

The scantlings of the cargo tank are to comply with the scantling requirements taking into account the internal pressure as indicated in 3-4/17.3.2 and any corrosion allowance required by 3-4/17.3.3.

17.3 Allowable Stresses and Corrosion Allowances

17.3.1 Allowable Stresses (1 September 2012)

For independent tanks primarily constructed of plane surfaces, the stresses for primary and secondary members (stiffeners, web frames, stringers, girders) when calculated by classical analysis procedures are not to exceed the lower of $R_m/2.66$ or $R_e/1.33$ for carbon- manganese steels and aluminum alloys, where

R_e = specified minimum yield stress at room temperature, in N/mm^2 (kgf/mm^2 , psi). If the stress-strain curve does not show a defined yield stress, the 0.2% proof stress applies.

R_m = specified minimum tensile strength at room temperature, in N/mm^2 (kgf/mm^2 , psi)

For welded connections in aluminum alloys the respective values of R_e or R_m in annealed conditions are to be used.

17.3.2 Scantling Requirements (1 September 2012)

The scantlings of independent tanks are not to be less than that required below:

17.3.2(a) Plating

i) *Steel*. The plating thickness is to be not less than t_s below:

$$t_s = 0.73sk(k_1p/f_1)^{1/2} \text{ mm (in.) but not less than 8.5 mm (0.33 in.)}$$

where

s = spacing of transverse bulkhead stiffeners, in mm (in.)

k_1 = 0.50

k = $(3.075(\alpha)^{1/2} - 2.077)/(\alpha + 0.272)$ $1 \leq \alpha \leq 2$
 = 1.0 $\alpha > 2$

α = aspect ratio of the panel (longer edge/shorter edge)

p = p_{gc} or maximum sloshing pressure, p_s , whichever is greater, in N/cm^2 (kgf/cm^2 , lbf/in^2)

In no case is p to be taken less than 2.50 N/cm^2 (0.255 kgf/cm^2 , 3.626 lbf/in^2).

p_{gc} = $p_o + (p_{gd})_{max}$ N/cm^2 (kgf/cm^2 , lbf/in^2)

p_o = cargo tank design vapor pressure in N/cm^2 (kgf/cm^2 , lbf/in^2), as defined in 3-1/3.11

p_{gd} = $\alpha_\beta Z_\beta k_3 \rho 10^{-4}$ N/cm^2 (kgf/cm^2 , lbf/in^2)

α_β = dimensionless acceleration, see 3-3/5.9.2

- Z_{β} = largest cargo tank liquid head in m (ft) above the point on the plates under consideration, see 3-3/5.9.2
- p_s = $k_s p_{is}$, not to be taken less than $k_s p_{is(mid)}$
- p_{is} = nominal sloshing pressure, as specified in 3-3/13.5.1
- $p_{is(mid)}$ = nominal sloshing pressure at the mid-tank of the bulkhead at the same height as the point under consideration.
- k_s = 1.0
- f_1 = permissible bending stress, in N/cm² (kgf/cm², lbf/in²)
 = $0.95 S_m f_y$
- ρ = maximum cargo density, in N/m³ (kgf/m³, lbf/ft³), at the design temperature, but ρ is not to be taken less than 4900 N/m³ (500 kgf/m³, 31.214 lbf/ft³)

All other parameters are as defined above.

ii) *Aluminum Alloy.* The plating thickness is to be obtained from the following equation:

$$t_a = [t_s] \left(\frac{\sigma_s}{\sigma_a} \right)^{\frac{1}{2}}$$

where

- t_a = required thickness of aluminum, in mm (in.)
- t_s = required thickness of steel based on mild steel
- σ_s = specified minimum yield stress of mild steel at room temperature, in N/mm² (kgf/mm², psi)
- σ_a = specified minimum yield stress of aluminum at room temperature, in N/mm² (kgf/mm², psi). If the stress-strain curve does not show a defined yield stress, the 0.2% proof stress applies.

17.3.2(b) Stiffeners.

Each of the stiffeners in steel or aluminum alloy in association with the plating to which it is attached is not to have a section modulus less than that required by the following equation

$$SM_R = M / \sigma_a$$

where

- M = $1000 K_1 c p s \ell^2 / k$ N-cm (kgf-cm, lbf-in)
- c = 1.0 for longitudinal and horizontal stiffeners
 = $1 + \gamma \ell / 10 p$ for vertical stiffeners
- K_1 = 1.0 for non-corrosive cargoes
 = 1.1 for corrosive cargoes
- k = 12 (12, 83.33)
- γ = specific weight of the liquid, not to be taken less than 0.49 N/cm²-m (0.05 kgf/cm²-m, 0.2168 lbf/in²-ft)

s	=	spacing of longitudinals or vertical/horizontal stiffeners, in mm (in.)
ℓ	=	span of longitudinals or stiffeners between effective supports, in m (ft)
p_{gc}	=	$p_o + (p_{ga})_{max}$ N/cm ² (kgf/cm ² , lbf/in ²)
p_o	=	cargo tank design vapor pressure in N/cm ² (kgf/cm ² , lbf/in ²), as defined in 3-1/3.11
p_{ga}	=	$a_{\beta}Z_{\beta}k_3\rho 10^{-4}$ N/cm ² (kgf/cm ² , lbf/in ²)
a_{β}	=	dimensionless acceleration, see 3-3/5.9.2
Z_{β}	=	largest cargo tank liquid head in m (ft) above the point on the bulkhead longitudinal or stiffener under consideration, see 3-3/5.9.2
k_3	=	9.81 (1.0, 69.44)
ρ	=	maximum cargo density, in N/m ³ (kgf/m ³ , lbf/ft ³), at the design temperature, but ρ is not to be taken less than 4900 N/m ³ (500 kgf/m ³ , 31.214 lbf/ft ³)
p	=	pressure, p_{gc} , in N/cm ² (kgf/cm ² , lbf/in ²), at the longitudinal or stiffener considered, as specified in 3-4/17.3.2(a), or maximum sloshing pressure, p_s , whichever is greater. For vertical stiffeners, pressure is to be taken at the middle of span of each stiffener.
p_s	=	c_3p_{is} , not to be taken less than $c_3p_{is(mid)}$
$p_{is(mid)}$	=	nominal slosh pressure at the mid-tank of the bulkhead at the same height as the point under consideration
p_{is}	=	nominal sloshing pressure, as specified in 3-3/13.5.1
c_3	=	1.0
σ_a	=	allowable stress not exceeding the lower of $R_m/2.66$ or $R_e/1.33$ for steel or aluminum alloy, respectively and R_m and R_e , as defined in 3-4/17.3.1

The effective breadth of plating, b_e , is as defined in line b) of 3-4/Figure 4.

The above section modulus requirements for cargo tank stiffeners in way of vertical supports, anti-pitch chocks and anti-roll chocks are to be increased by 25%.

If the tank spaces on both sides of the longitudinal bulkheads are always loaded to the same level, the initial scantlings may be taken as 90% of the required values in 3-4/17.3.2(a) for plating and 3-4/17.3.2(b) for stiffeners. However, the reduction in the required thickness is not more than 1 mm (0.04 in.).

The scantlings of the cargo tank structure are to be verified for compliance with the yielding and buckling requirements in Chapter 3, Section 5.

17.3.2(c) Corrugated Bulkheads. Corrugated bulkheads are not to be used for primary barriers.

17.3.2(d) Webs and Girders.

Webs and girders in steel and aluminum alloy in association with the plating to which it is attached are not to have a section modulus less than that required by the following equation:

$$SM_R = SMK_1K_3/\sigma_a$$

where

$$SM = 4.74chs\ell^2 \text{ cm}^3$$

$$= 0.025chs\ell^2 \text{ in}^3$$

$$c = 1.50$$

h = vertical distance, in m (ft), from the middle of s in the case of girders and from the middle of ℓ in the case of webs to the same heights to which for the stiffeners is measured

s = sum of half lengths (on each side of girder nor web) of the frames or stiffeners supported, in m (ft)

ℓ = span of web and girders between effective supports, in m (ft), as shown in 3-4/Figure 3, in m

$$K_3 = 124 \text{ N/mm}^2 (12.6 \text{ kgf/mm}^2, 17900 \text{ psi})$$

K_1 and σ_a are defined in 3-4/17.3.2(b) above.

17.3.2(e) Nontight Bulkheads. Nontight bulkheads in cargo tanks are to be fitted in line with transverse webs or other structures with equivalent rigidity. They are to be suitably stiffened. Openings in the nontight bulkhead are to have generous radii. The thickness of nontight bulkheads is to be not less than 6.5 mm (0.26 in.). Section moduli of stiffeners and webs may be half of requirements in 3-4/17.3.2(b) and 3-4/17.3.2(d) with = 0.6 and 1.0, respectively.

Alternatively, the opening ratio and scantlings may be determined by an acceptable method of engineering analysis.

17.3.3 Corrosion Allowances

No corrosion allowance is generally required in addition to the thickness resulting from the structural analysis. However, where there is no environmental control around the cargo tank, such as inerting, or where the cargo is of a corrosive nature, a suitable corrosion allowance is to be provided.

Note:

Special attention to stress corrosion cracking (SCC) is needed when cargo tanks are to be designed to carry anhydrous ammonia. SCC may cause cracking without visible reduction in plate thickness. See 5C-8-17/12 of the *Marine Vessel Rules* for details of the SCC phenomena and prevention for such cargo tanks.

19 Supports

Independent cargo tanks are to be supported by the hull in a manner which will prevent bodily movement of the tanks under static and dynamic loads while allowing contraction and expansion of the tanks under temperature variations and hull deflections without undue stressing of the tanks and of the hull.

In general, the protruding part of a support (chock) is to be fitted to the cargo tanks to prevent potential problems associated with undue tightness at the contact surfaces due to shrinkage of the cargo tanks under low cargo temperature.

CHAPTER 3 Structural Design Requirements

SECTION 5 Total Strength Assessment

1 General Requirements

1.1 General

In assessing the adequacy of the structural configuration and the initially selected scantlings, the strength of the hull girder and the individual structural member or element is to be in compliance with the failure criteria specified in 3-5/3 below. In this regard, the structural response is to be calculated by performing a structural analysis, as specified in 3-5/9, or by other equivalent and effective means. Due consideration is to be given to structural details, as specified in 3-4/1.5.

1.3 Loads and Load Cases

In determination of the structural response, the combined load cases given in 3-3/9.3 are to be considered together with sloshing loads specified in 3-3/11. Deck loads as specified in Chapter 3, Section 7 are also to be considered. If this information is not yet available, the deck loads as indicated in 3-3/17 are to be used. Bowflare/bottom slamming and other loads, as specified in 3-3/15, are also to be considered as necessary.

1.5 Stress Components

The total stress, in stiffened plate panels, is divided into the following three categories:

1.5.1 Primary

Primary stresses are those resulting from hull girder bending. The primary bending stresses may be determined by simple beam method using the specified total vertical and horizontal bending moments and the effective net hull girder section modulus at the section considered. These primary stresses, designated by f_{L1} (f_{L1V} , f_{L1H} for vertical and horizontal bending, respectively), may be regarded as uniformly distributed across the thickness of plate elements, at the same level measuring from the relevant neutral axis of the hull girder.

1.5.2 Secondary

Secondary stresses are those resulting from bending of large stiffened panels between longitudinal and transverse bulkheads, due to local loads in an individual cargo or ballast tank.

The secondary bending stresses, designated by f_{L2} or f_{T2} , are to be determined by performing a 3D FEM analysis as outlined in this section.

For stiffened hull structures, there is another secondary stress due to the bending of longitudinals or stiffeners with the associated plating between deep supporting members or floors. The latter secondary stresses are designated by f_{L2}^* or f_{r2}^* , and may be approximated by simple beam theory.

The secondary stresses, f_{L2} , f_{T2} , f_{L2}^* or f_{r2}^* , may be regarded as uniformly distributed in the flange plating and face plates.

1.5.3 Tertiary

Tertiary stresses are those resulting from the local bending of plate panels between stiffeners. The tertiary stresses, designated by f_{L3} or f_{T3} , can be calculated from classic plate theory. These stresses are referred to as point stresses at the surface of the plate.

3 Failure Criteria - Yielding

3.1 General

The calculated stresses in the hull structure are to be within the limits given below for all the combined load cases specified in 3-3/9.3.1.

3.3 Structural Members and Elements

For all structural members and elements, such as longitudinals/stiffeners, web plates and flanges, the combined effects of all the calculated stress components are to satisfy the following limits.

$$f_i \leq S_m f_y$$

where

- f_i = stress intensity
= $(f_L^2 + f_T^2 - f_L f_T + 3 f_{LT}^2)^{1/2}$ N/cm² (kgf/cm², lbf/in²)
- f_L = calculated total in-plane stress in the longitudinal direction including primary and secondary stresses
= $f_{L1} + f_{L2} + f_{L2}^*$ N/cm² (kgf/cm², lbf/in²)
- f_{L1} = direct stress due to the primary (hull girder) bending, N/cm² (kgf/cm², lbf/in²)
- f_{L2} = direct stress due to the secondary bending between bulkheads in the longitudinal direction, N/cm² (kgf/cm², lbf/in²)
- f_{L2}^* = direct stress due to local bending of longitudinal between transverses in the longitudinal direction, N/cm² (kgf/cm², lbf/in²)
- f_T = calculated total direct stress in the transverse/vertical direction, including secondary stresses
= $f_{T1} + f_{T2} + f_{T2}^*$ N/cm² (kgf/cm², lbf/in²)
- f_{LT} = calculated total in-plane shear stress, N/cm² (kgf/cm², lbf/in²)
- f_{T1} = direct stress due to sea and cargo load in the transverse/vertical direction, N/cm² (kgf/cm², lbf/in²)
- f_{T2} = direct stress due to the secondary bending between bulkheads in the transverse/vertical direction, N/cm² (kgf/cm², lbf/in²)
- f_{T2}^* = direct stress due to local bending of stiffeners in the transverse/vertical direction, N/cm² (kgf/cm², lbf/in²)
- f_y = specified minimum yield point, N/cm² (kgf/cm², lbf/in²)
- S_m = strength reduction factor, as defined in 3-4/7.3.1

For this purpose, f_{L2}^* and f_{T2}^* in the flanges of longitudinal and stiffener, at the ends of span may be obtained from the following equation:

$$f_{L2}^*(f_{T2}^*) = 0.071sp\ell^2 / SM_L(SM_T) \quad \text{N/cm}^2 \text{ (kgf/cm}^2, \text{ lbf/in}^2\text{)}$$

where

- s = spacing of longitudinals (stiffeners), in cm (in.)
- ℓ = unsupported span of the longitudinal (stiffener), in cm (in.)
- p = net pressure load, in N/cm² (kgf/cm², lbf/in²), for the longitudinal (stiffener)
- $SM_L(SM_T)$ = net section modulus, in cm³ (in³), of the longitudinal (stiffener)

3.5 Plating

For plating away from knuckle or cruciform connection of high stress concentrations and subject to both in-plane and lateral loads, the combined effects of all the calculated stress components are to satisfy the limits specified in 3-5/3.3 with f_L and f_T modified as follows:

$$f_L = f_{L1} + f_{L2} + f_{L2}^* + f_{L3} \quad \text{N/cm}^2 \text{ (kgf/cm}^2, \text{ lbf/in}^2\text{)}$$

$$f_T = f_{T1} + f_{T2} + f_{T2}^* + f_{T3} \quad \text{N/cm}^2 \text{ (kgf/cm}^2, \text{ lbf/in}^2\text{)}$$

where

f_{L3}, f_{T3} = plate bending stresses between stiffeners in the longitudinal and transverse directions, respectively, and may be approximated as follows.

$$f_{L3} = 0.182p(s/t_n)^2 \quad \text{N/cm}^2 \text{ (kgf/cm}^2, \text{ lbf/in}^2\text{)}$$

$$f_{T3} = 0.266k^2p(s/t_n)^2 \quad \text{N/cm}^2 \text{ (kgf/cm}^2, \text{ lbf/in}^2\text{)}$$

$$k = \begin{cases} (3.075(\alpha)^{1/2} - 2.077)/(\alpha + 0.272) & (1 \leq \alpha \leq 2) \\ 1.0 & (\alpha > 2) \end{cases}$$

α = aspect ratio of the panel (longer edge/shorter edge)

p = lateral pressures for the combined load case considered (see 3-3/9), in N/cm² (kgf/cm², lbf/in²)

s = spacing of longitudinals or stiffeners, in mm (in.)

t_n = net plate thickness, in mm (in.)

For plating within two longitudinal or stiffeners from knuckle or cruciform connections of high stress concentrations, the combined effects of the calculated stress components are as follows:

$$f_i \leq 0.80S_m f_y$$

where

f_i = stress intensity

$$= (f_L^2 + f_T^2 - f_L f_T + 3f_{LT}^2)^{1/2} \text{ N/cm}^2 \text{ (kgf/cm}^2, \text{ lbf/in}^2\text{)}$$

f_L = calculated total in-plane stress in the longitudinal direction including primary and secondary stresses

$$= f_{L1} + f_{L2} \text{ N/cm}^2 \quad (\text{kgf/cm}^2, \text{ lbf/in}^2)$$

f_T = calculated total direct stress in the transverse/vertical direction, including secondary stresses

$$= f_{T1} + f_{T2} \text{ N/cm}^2 \quad (\text{kgf/cm}^2, \text{ lbf/in}^2)$$

In addition, the failure criteria for knuckle or cruciform connections in 3-A5/11 are to be complied with.

f_{L1} , f_{L2} , f_{L2}^* , f_{T1} , f_{T2} and f_{T2}^* are as defined in 3-5/3.3.

3.7 Allowable Stresses for Independent Cargo Tanks

3.7.1 Allowable Stresses for Independent Cargo Tank Boundaries

The allowable stresses are applicable to plating and longitudinal stiffeners on watertight boundaries of independent cargo tanks. Application of the allowable stress to rod and beam elements is based on axial stress while von-Mises membrane stresses for quadrilateral elements are checked.

3.7.1(a) Type B Independent Tanks, Primarily Constructed of Bodies of Revolution

- Nickel Steels and Carbon-Manganese Steels

The lesser of $R_m/3.0$ or $R_e/2$

- Austenitic Steels

The lesser of $R_m/3.5$ or $R_e/1.6$

- Aluminum Alloys

The lesser of $R_m/4.0$ or $R_e/1.5$

3.7.1(b) Type B Independent Tanks, Primarily Constructed of Plane Surfaces

- Nickel Steels and Carbon-Manganese Steels

The lesser of $R_m/2.0$ or R_e for plating

The lesser of $R_m/2.0$ or $R_e/1.33$ for stiffeners

- Austenitic Steels

The lesser of $R_m/2.0$ or R_e for plating

The lesser of $R_m/2.5$ or $R_e/1.25$ for stiffeners

- Aluminum Alloys

The lesser of $R_m/2.0$ or R_e for plating

The lesser of $R_m/2.5$ or $R_e/1.33$ for stiffeners

3.7.1(c) Type C Independent Tanks

- Nickel Steels and Carbon-Manganese Steels

The lesser of $R_m/3.0$ or $R_e/2$

- Austenitic Steels

The lesser of $R_m/3.5$ or $R_e/1.6$

- Aluminum Alloys

The lesser of $R_m/4.0$ or $R_e/1.5$

R_m and R_e are defined in 3-4/17.3.1.

3.7.2 Allowable Stresses for Independent Cargo Tank Main Supporting Members

The allowable stresses are applicable to main supporting members in the independent cargo tanks.

3.7.2(a) Type B Independent Tanks, Primarily Constructed of Bodies of Revolution

- Nickel Steels and Carbon-Manganese Steels

The lesser of $R_m/2.0$ or R_e

Note:

In way of the supports of the independent cargo tanks made of Carbon-Manganese Steels, the allowable stresses are not to be more than the lesser of $0.57R_m$ or $0.85R_e$.

- Austenitic Steels

The lesser of $R_m/2.0$ or R_e

- Aluminum Alloys

The lesser of $R_m/2.0$ or R_e

3.7.2(b) Type B Independent Tanks, Primarily Constructed of Plane Surfaces

- Nickel Steels and Carbon-Manganese Steels

The lesser of $R_m/2.0$ or $R_e/1.33$

- Austenitic Steels

The lesser of $R_m/2.5$ or $R_e/1.25$

- Aluminum Alloys

The lesser of $R_m/2.5$ or $R_e/1.33$

3.7.2(c) Type C Independent Tanks

- Nickel Steels and Carbon-Manganese Steels

The lesser of $R_m/2.0$ or R_e

- Austenitic Steels

The lesser of $R_m/2.0$ or R_e

- Aluminum Alloys

The lesser of $R_m/2.0$ or R_e

R_m and R_e are defined in 3-4/17.3.1. For the mesh size other than the recommended one longitudinal spacing, the allowable stresses defined above for Type B and Type C independent tanks are to be adjusted in the same way as that in 3-5/3.9 TABLE 1.

3.9 Allowable Stresses for Main Supporting Members and Structural Details

The allowable stresses defined in 3-5/3.9 TABLE 1 are applicable to main supporting members and structural details in the hull structure, except seatings for supports and chocks for independent cargo tanks which are specified in 3-5/3.11 TABLE 2. The allowable stress for the recommended basic mesh size is defined as a percentage of the minimum specified yield stress f_y times the strength reduction factor S_m . Application of this allowable stress to rod and beam elements is based on axial stress while von-Mises membrane stresses for quadrilateral elements are checked.

To calculate the local stress distribution in a main supporting member, it is often necessary to model openings, details and discontinuities using various mesh sizes. In areas of high stress gradient, the allowable stresses are to be adjusted according to mesh sizes and are listed in 3-5/3.9 TABLE 1 below.

TABLE 1
Allowable Stresses (kgf/cm²) for Various Finite Element Mesh Sizes

Mesh Size	Stress Limit	Mild Steel ($S_m = 1.000$)	HT27 ($S_m = 0.980$)	HT32 ($S_m = 0.950$)	HT36 ($S_m = 0.908$)
1 × LS	$1.00 \times c_f S_m f_y$	$2400 \times c_f$	$2646 \times c_f$	$3040 \times c_f$	$3269 \times c_f$
$\frac{1}{2} \times LS^{(1)}$	$1.06 \times c_f S_m f_y$	$2544 \times c_f$	$2805 \times c_f$	$3222 \times c_f$	$3465 \times c_f$
$\frac{1}{3} \times LS^{(1)}$	$1.12 \times c_f S_m f_y$	$2688 \times c_f$	$2963 \times c_f$	$3404 \times c_f$	$3661 \times c_f$
$\frac{1}{4} \times LS^{(1)}$	$1.18 \times c_f S_m f_y$	$2832 \times c_f$	$3122 \times c_f$	$3587 \times c_f$	$3857 \times c_f$
$\frac{1}{5} \times LS \sim \frac{1}{10} \times LS^{(1)}$	$1.25 \times c_f S_m f_y$	$3000 \times c_f$	$3308 \times c_f$	$3800 \times c_f$	$4086 \times c_f$
Thickness ^(1,2)	$c_f f_u$ or $1.50 \times c_f S_m f_y$	$4100 \times c_f$	$c_f f_u$ or $1.50 \times c_f S_m f_y$	$4500 \times c_f$	$4903 \times c_f$

Notes

- 1 Stress limits greater than $1.00 \times c_f S_m f_y$ are to be restricted to small areas in way of structural discontinuities.
- 2 When the fatigue strength of the detail is found satisfactory, the hot spot stress in the detail may be allowed up to the minimum tensile strength of the material.
- 3 c_f is to be taken as 1.0 for dynamic sea load cases in 3-3/Tables 1A and 1D.
 c_f is to be taken as 0.85 for port condition (SLC1) and 1.00 for flooded load case (SLC2) in 3-3/Table 1C.
- 4 The allowable stresses are not applicable to accidental load cases (SLC3 ~ SLC5) in 3-3/Tables 1C.

3.11 Allowable Stresses for Vertical Supports and Chocks

The allowable stresses described in this Subsection are applicable to seatings for supports and chocks. The allowable stress for the recommended basic mesh size is the minimum specified yield stress f_y times the strength reduction factor S_m as given in 3-5/3.11 TABLE 2. Application of this allowable stress to rod and beam elements is based on axial stress while von-Mises membrane stresses for quadrilateral elements are checked.

TABLE 2
Allowable Stresses (kgf/cm²) for Various Finite Element Mesh Sizes

Mesh Size	Stress Limit	Mild Steel ($S_m = 1.000$)	HT27 ($S_m = 0.980$)	HT32 ($S_m = 0.950$)	HT36 ($S_m = 0.908$)
1 × LS	$1.00 \times c_f S_m f_y$	$2400 \times c_f$	$2646 \times c_f$	$3040 \times c_f$	$3269 \times c_f$
$\frac{1}{2} \times LS^{(1)}$	$1.06 \times c_f S_m f_y$	$2544 \times c_f$	$2805 \times c_f$	$3222 \times c_f$	$3465 \times c_f$
$\frac{1}{3} \times LS^{(1)}$	$1.12 \times c_f S_m f_y$	$2688 \times c_f$	$2963 \times c_f$	$3404 \times c_f$	$3661 \times c_f$

Mesh Size	Stress Limit	Mild Steel ($S_m = 1.000$)	HT27 ($S_m = 0.980$)	HT32 ($S_m = 0.950$)	HT36 ($S_m = 0.908$)
$\frac{1}{4} \times LS^{(1)}$	$1.18 \times c_f S_m f_y$	$2832 \times c_f$	$3122 \times c_f$	$3587 \times c_f$	$3857 \times c_f$
$\frac{1}{5} \times LS \sim \frac{1}{10} \times LS (1)$	$1.25 \times c_f S_m f_y$	$3000 \times c_f$	$3308 \times c_f$	$3800 \times c_f$	$4086 \times c_f$
Thickness ^(1,2)	$c_f f_u$ or $1.50 \times c_f S_m f_y$	$4100 \times c_f$	$c_f f_u$ or $1.50 \times c_f S_m f_y$	$4500 \times c_f$	$4903 \times c_f$

Notes

- 1 Stress limits greater than $1.00 \times c_f S_m f_y$ are to be restricted to small areas in way of structural discontinuities.
- 2 When the fatigue strength of the detail is found satisfactory, the hot spot stress in the detail may be allowed up to the minimum tensile strength of the material.
- 3 c_f is to be taken as 0.85 for dynamic sea load cases in 3-3/Tables 1A and 1D.
 c_f is to be taken as 1.00 for accidental load case (SLC3 ~ SLC5) in 3-3/Table 1C
- 4 The allowable stresses are not applicable to SLC1 and SLC2 in 3-3/Tables 1C.

Contact surfaces of vertical supports, anti-roll and anti-pitch chocks are usually made of synthetic materials such as resin, plywood and adhesive. The strength of each contact surface is to be verified under the maximum contact force perpendicular to the surface and the associated friction parallel to the surface. Contact forces are to be calculated from global finite element models. The frictional coefficient for strength verification of the contact surface is to be taken as 0.3. Average compressive and shear stresses in each layer of the synthetic contact surface are to be separately checked against the safe working stresses. The strength of the fastening bolts or other effective means is to be evaluated. The following safety factors for vertical supports and chocks under sea-going and accidental load cases are to be complied with:

- *Vertical Supports*

- | | |
|-------------------------------------|---------------------|
| LC1 ~ LC8 (Dynamic Sea Load Cases): | Safety Factor = 3.5 |
| SLC5 (30° Static Heel): | Safety Factor = 3.5 |
| SLC4 (Accidental Load Cases): | Safety Factor = 1.5 |

- *Anti-pitch Chocks*

- | | |
|-------------------------------------|---------------------|
| LC1 ~ LC8 (Dynamic Sea Load Cases): | Safety Factor = 3.5 |
| SLC4 (Accidental Load Cases): | Safety Factor = 1.5 |

- *Anti-roll Chocks*

- | | |
|-------------------------------------|---------------------|
| LC1 ~ LC8 (Dynamic Sea Load Cases): | Safety Factor = 3.5 |
| SLC5 (30° Static Heel): | Safety Factor = 3.5 |

- *Anti-flotation Chocks*

- | | |
|-----------------------------------|---------------------|
| SLC3 (Anti-flotation Load Cases): | Safety Factor = 3.5 |
|-----------------------------------|---------------------|

5 Failure Criteria - Buckling and Ultimate Strength

5.1 General

5.1.1 Approach

The strength criteria given here correspond to either serviceability (buckling) state limits or ultimate state limits for structural members and panels, according to the intended functions and

buckling resistance capability of the structure. For plate panels between stiffeners, buckling in the elastic range is acceptable provided that the ultimate strength of the structure satisfies the specified design limits. The critical buckling stresses and ultimate strength of structures may be determined based on either well-documented experimental data or a calibrated analytical approach. When a detailed analysis is not available, the equations given in Chapter 3, Appendix 2 may be used to assess the buckling strength. However, for plate panels on which insulation systems are installed, the maximum deflection of the plate panel is not to be greater than 4.6 mm (0.18 in.) in the elastic buckling range.

5.1.2 Buckling Control Concepts

The strength criteria, in 3-5/5.3 through 3-5/5.11 are based on the following assumptions and limitations with respect to buckling control in design.

5.1.2(a) The buckling strength of longitudinals and stiffeners is generally greater than that of the plate panels they support.

5.1.2(b) All longitudinals with their associated effective plating are to have moments of inertia not less than given in 3-A2/11.1.

5.1.2(c) The main supporting members, including transverses, girders and floors, with their associated effective plating are to have the moments of inertia not less than given in 3-A2/11.5.

In addition, tripping (e.g., torsional instability) is to be prevented as specified in 3-A2/9.5.

5.1.2(d) Face plates and flanges of girders, longitudinals and stiffeners are proportioned such that local instability is prevented. (See 3-A2/11.7)

5.1.2(e) Webs of longitudinals and stiffeners are proportioned such that local instability is prevented. (See 3-A2/11.9).

5.1.2(f) Webs of girders, floors and transverses are designed with proper proportions and stiffening systems to prevent local instability. Critical buckling stresses of the webs may be calculated from equations given in 3-A2/3.

For structures which do not satisfy these assumptions, a detailed analysis of buckling strength using an acceptable method is to be submitted for review.

5.3 Plate Panels

5.3.1 Buckling State Limit

The buckling state limit for plate panels between stiffeners is defined by the following equation:

$$(f_L/f_{cL})^2 + (f_T/f_{cT})^2 + (f_{LT}/f_{cLT})^2 \leq 1.0$$

where

$f_L = f_{L1} + f_{L2} =$ calculated total compressive stress in the longitudinal direction for the plate, in N/cm² (kgf/cm², lbf/in²), induced by bending of the hull girder and large stiffened panels between bulkheads

$f_T = f_{T1} + f_{T2} =$ calculated total compressive stress in the transverse/vertical direction, in N/cm² (kgf/cm², lbf/in²)

$f_{LT} =$ calculated total in-plane shear stress, in N/cm² (kgf/cm², lbf/in²)

f_{cL} , f_{cT} and f_{cLT} are the critical buckling stresses corresponding to uniaxial compression in the longitudinal, transverse/vertical directions and edge shear, respectively, in N/cm² (kgf/cm², lbf/in²), and may be determined from the equations given in 3-A2/3.

f_L , f_T and f_{LT} are to be determined for the panel in question under the load cases specified in 3-3/9 including the primary and secondary stresses as defined in 3-5/3.1.

5.3.2 Effective Width

When the buckling state limit specified in 3-5/5.3.1 above is not satisfied, the effective width b_{wL} or b_{wT} of the plating given below is to be used instead of the full width between longitudinals, s , for determining the effective hull girder section modulus, SM_e , specified in 3-5/5.11 and also for verifying the ultimate strength as specified in 3-5/5.3.3 below. When the buckling state limit in 3-5/5.3.1 above is satisfied, the full width between longitudinals, s , may be used as the effective width, b_{wL} , for verifying the ultimate strength of longitudinals and stiffeners specified in 3-5/5.5, and for determining the effective hull girder section modulus SM_e specified in 3-5/5.11 below.

5.3.2(a) For long plate:

$$b_{wL}/s = C$$

where

$$C = \begin{aligned} & 2.25/\beta - 1.25/\beta^2 && \text{for } \beta \geq 1.25 \\ & 1.0 && \text{for } \beta < 1.25 \end{aligned}$$

$$\beta = (f_y/E)^{1/2} s/t_n$$

s = stiffener spacing, in mm (in.)

t_n = net thickness of the plate, in mm (in.)

E = Young's modulus, in N/cm² (kgf/cm², lbf/in²), for steel 2.06×10^7 (2.10×10^6 , 30×10^6)

f_y = specified minimum yield point of the material, in N/cm² (kgf/cm², lbf/in²)

5.3.2(b) For wide plate (compression in transverse direction):

$$b_{wT}/\ell = Cs/\ell + 0.115(1 - s/\ell)(1 + 1/\beta^2)^2 \leq 1.0$$

where

ℓ = spacing of transverses, in cm (in.)

s = longitudinal spacing, in cm (in.)

C , β are as defined in 3-5/5.3.2(a) above.

5.3.3 Ultimate Strength

The ultimate strength of a plate panel between stiffeners is to satisfy all of the following equations:

$$(f_L/f_{uL})^2 + (f_{LT}/f_{uLT})^2 \leq S_m$$

$$(f_T/R_t f_{uT})^2 + (f_{LT}/f_{uLT})^2 \leq S_m$$

$$(f_L/f_{uL})^2 + (f_T/f_{uT})^2 - \eta(f_L/f_{uL})(f_T/f_{uT}) + (f_{LT}/f_{uLT})^2 \leq S_m$$

where

f_L , f_T and f_{LT} are as defined in 3-5/5.3.1 above.

S_m is as defined in 3-4/7.3.1.

$$\eta = 1.5 - \beta/2 \geq 0$$

β is as defined in 3-5/5.3.2 above.

f_{uL} , f_{uT} and f_{uLT} are the ultimate strengths with respect to uniaxial compression and edge shear, respectively, and may be obtained from the following equations, except that they need not be taken less than the corresponding critical buckling stresses specified in 3-5/5.3.1 above.

$$f_{uL} = f_y b_{wL} / s$$

$$f_{uT} = f_y b_{wT} / \ell$$

$$f_{uLT} = f_{cLT} + 0.5(f_y - f_{cLT}) / (1 + \alpha + \alpha^2)^{1/2}$$

where

$$\alpha = \ell / s$$

f_y , b_{wL} , b_{wT} , s , ℓ and f_{cLT} are as defined above.

For assessing the ultimate strength of plate panels between stiffeners, special attention is to be paid to the longitudinal bulkhead plating in the regions of high hull girder shear forces and the bottom and inner bottom plating in the mid portion of cargo tanks subject to bi-axial compression.

5.5 Longitudinals and Stiffeners

5.5.1 Beam-Column Buckling State Limits and Ultimate Strength

The buckling state limits for longitudinals and stiffeners are considered as the ultimate state limits for these members and are to be determined as follows:

$$f_a / (f_{ca} A_e / A) + m f_b / f_y \leq S_m$$

where

f_a = nominal calculated compressive stress

$$= P/A \text{ N/cm}^2 \text{ (kgf/cm}^2, \text{ lbf/in}^2\text{)}$$

P = total compressive load, N (kgf, lbf)

f_{ca} = critical buckling stress as given in 3-A2/5.1, N/cm² (kgf/cm², lbf/in²)

A = total net sectional area, cm² (in²)

$$= A_s + s t_n$$

A_s = net sectional area of the longitudinal, excluding the associated plating, cm² (in²)

A_e = effective net sectional area, cm² (in²)

$$= A_s + b_{wL} t_n$$

b_{wL} = effective width, as specified in 3-5/5.3.2 above

- E = Young's modulus, 2.06×10^7 N/cm² (2.1×10^6 kgf/cm², 30×10^6 lbf/in²) for steel
- f_y = minimum specified yield point of the longitudinal or stiffener under consideration, N/cm² (kgf/cm², lbf/in²)
- f_b = bending stress, N/cm² (kgf/cm², lbf/in²)
 = $M/S M_e$
- M = maximum bending moment induced by lateral loads
 = $c_m p s \ell^2 / 12$ N-cm (kgf-cm, lbf-in)
- c_m = moment adjustment coefficient, and may be taken as 0.75
- p = lateral pressure for the region considered, N/cm² (kgf/cm², lbf/in²)
- s = spacing of the longitudinals, cm (in.)
- $S M_e$ = effective section modulus of the longitudinal at flange, accounting for the effective breadth, b_e , cm³ (in³)
- b_e = effective breadth, as specified in 3-4/Figure 4, line b
- m = amplification factor
 = $1/[1 - f_a/\pi^2 E(r/\ell)^2] \geq 1.0$

S_m is as defined in 3-4/7.3.1.

r and ℓ are as defined in 3-A2/5.1.

5.5.2 Torsional-Flexural Buckling

In general, the torsional-flexural buckling strength of longitudinals and stiffeners is to satisfy the design limits given below:

$$f_a / (f_{ct} A_e / A) \leq S_m \quad \text{N/cm}^2 \text{ (kgf/cm}^2 \text{, lbf/in}^2\text{)}$$

where

- f_a = nominal calculated compressive stress, as defined in 3-5/5.5.1 above
- f_{ct} = critical torsional-flexural buckling stress, and may be determined by equations given in 3-A2/5.3.

A_e and A are as defined in 3-5/5.5.1 above and S_m is as defined in 3-4/7.3.1.

5.7 Stiffened Panels

5.7.1 Large Stiffened Panels between Bulkheads

For a double hull floating terminal, assessment of buckling state limit is not required for the large stiffened panels of the bottom and inner bottom structures, side shell and inner skin. Assessments of the buckling state limits are to be performed for large stiffened panels of the deck structure and other longitudinal bulkheads. In this regard, the buckling strength is to satisfy the following condition for uniaxially or orthogonally stiffened panels.

$$(f_{L1}/f_{cL})^2 + (f_{T1}/f_{cT})^2 \leq S_m$$

where

f_{L1}, f_{T1} = calculated average compressive stresses in the longitudinal and transverse/ vertical directions respectively, as defined in 3-5/3.3 above

f_{cL}, f_{cT} = critical buckling stresses for uniaxial compression in the longitudinal and transverse direction, respectively, and may be determined in accordance with 3-A2/7, in N/cm² (kgf/cm², lbf/in²)

S_m = strength reduction factor, as defined in 3-4/7.3.1

5.7.2 Uniaxially Stiffened Panels between Transverses and Girders

The buckling strength of uniaxially stiffened panels between deep transverses and girders is also to be examined in accordance with the specifications given in 3-5/5.7.1 above by replacing f_{L1} and f_{T1} with f_{Lb} and f_{Tb} , respectively. f_{Lb} and f_{Tb} are as defined in 3-5/5.3.1 above.

5.9 Girders and Webs

5.9.1 Buckling Criteria

In general, the stiffness of the web stiffeners along the depth of the web plating is to be in compliance with the requirements of 3-A2/11.3. Web stiffeners which are oriented parallel to and near the face plate, and thus subject to axial compression, are also to satisfy the limits specified in 3-5/5.5, considering the combined effect of the compressive and bending stresses in the web. In this case, the unsupported span of these parallel stiffeners may be taken between tripping brackets, as applicable.

The buckling strength of the web plate between stiffeners and flange/face plate is to satisfy the limits specified below.

5.9.1(a) For web plate:

$$(f_L/f_{cL})^2 + (f_b/f_{cb})^2 + (f_{LT}/f_{cLT})^2 \leq S_m$$

where

f_L = calculated uniform compressive stress along the length of the girder, N/cm² (kgf/cm², lbf/in²)

f_b = calculated ideal bending stresses, in N/cm² (kgf/cm², lbf/in²)

f_{LT} = calculated total in-plane shear stress, in N/cm² (kgf/cm², lbf/in²)

f_L, f_b and f_{LT} are to be calculated for the panel in question under the combined load cases specified in 3-3/9.3, and these stresses may be calculated from the relative displacements of four corner nodes. This method is useful when the meshing within the panel is irregular. However, care should be taken when one corner of the panel is located in an area of high stress concentration or the panel shape is significantly different from a rectangular shape. The calculated stresses from the above mentioned method tend to be on the conservative side. If one corner of the panel is highly stressed and if the mesh is sufficiently refined, the plate panel stresses may be calculated from the displacements slightly away from the corner point of the high stress concentration area. For a regularly meshed plate panel, f_L, f_b and f_{LT} may also be calculated directly from the components stresses for the elements in the panel.

f_{cL}, f_{cb} and f_{cLT} are critical buckling stresses with respect to uniform compression, ideal bending and shear, respectively, and may be determined in accordance with Chapter 3, Appendix 2. S_m is as defined in 3-4/7.3.1.

In the determination of f_{cL} and f_{cLT} the effects of openings are to be considered.

5.9.1(b) The breadth to thickness ratio of face plate and flange is to satisfy the limits given in 3-A2/11.

5.9.1(c) The buckling strength is to satisfy the limits specified in 3-5/5.9.1(a) above for web plate.

5.9.2 Tripping

Tripping brackets are to be provided in accordance with 3-A2/9.5.

5.11 Independent Cargo Tank Structures

For type B and C independent tanks made of higher strength materials and aluminum alloys, calculations are to be submitted to show adequate provision to resist buckling.

7 Fatigue Life

7.1 General

An analysis is to be made of the fatigue strength of welded joints and details, in highly stressed areas, especially where higher strength steel is used. Special attention is to be given to structural notches, cutouts, and bracket toes, and also to abrupt changes of structural sections. A simplified assessment of the fatigue strength of structural details may be accepted when carried out in accordance with Chapter 3, Appendix 1 “Guide for Fatigue Strength Assessment”.

The following subparagraphs are intended to emphasize the main points and to outline procedures where refined spectral analysis techniques are used to establish fatigue strength.

7.1.1 Workmanship

As most fatigue data available were experimentally developed under controlled laboratory conditions, consideration is to be given to the workmanship expected during construction.

7.1.2 Fatigue Data

In the selection of S-N curves and the associated stress concentration factors, attention is to be paid to the background of all design data and its validity for the details being considered. In this regard, recognized design data, such as those by AWS (American Welding Society), API (American Petroleum Institute), and DEN (Department of Energy), should be considered. Sample fatigue data and their applications are shown in Chapter 3, Appendix 1, “Guide for Fatigue Strength Assessment”.

If other fatigue data are to be used, the background and supporting data are to be submitted for review.

In this regard, clarification is required whether or not the stress concentration due to the weld profile, certain structural configurations and also the heat effects are accounted for in the proposed S-N curve. Consideration is also to be given to the additional stress concentrations.

7.1.3 Total Stress Range

For determining total stress ranges, the fluctuating stress components resulting from the load combinations specified in 3-A1/7.5 are to be considered.

7.1.4 Design Consideration

In design, consideration is to be given to the minimization of structural notches and stress concentrations. Areas subject to highly concentrated forces are to be properly configured and stiffened to dissipate the concentrated loads. See also 3-4/1.5.

7.3 Procedures

The analysis of fatigue strength for a welded structural joint/detail may be performed in accordance with the following procedures.

7.3.1 Step 1 - Classification of Various Critical Locations

The class designations and associated load patterns are given in 3-A1/Table 1

7.3.2 Step 2 - Calculation of Fatigue Life

7.3.3 Step 3 - Refined Analysis

For structural details for which the calculated fatigue life obtained from Step 2 are less than the design fatigue life, or for which the fatigue characteristics are not covered by the classified details and associated S-N curves, refined analyses are to be performed as outlined in 3-5/7.3.3(a) or 3-5/7.3.3(b) below.

The fatigue life of structures is generally not to be less than 20 years unless otherwise specified.

7.3.3(a) Alternatively, a spectral analysis may be performed as outlined in 3-5/7.5 below to directly calculate fatigue lives for the structural details in question.

7.3.3(b) For structural details which are not covered by the detail classifications, proposed S-N curves and the associated SCF's, when applicable, may be submitted for consideration. In this regard, sufficient supporting data and background are also to be submitted for review. The refined SCF's may be determined by finite element analyses.

7.5 Spectral Analysis

Where the option in 3-5/7.3.3(a) is exercised, a spectral analysis is to be performed in accordance with the following guidelines.

7.5.1 Representative Loading Patterns

Several representative loading patterns are to be considered to cover the worst scenarios anticipated for the design service life of the vessel with respect to hull girder local loads.

7.5.2 Environmental Representation

Instead of the design wave loads specified in Chapter 3, Section 3, a wave scatter diagram (such as Walden's Data) is to be employed to simulate a representative distribution of all the wave conditions expected for the design service life of the floating terminal. In general, the wave data is to cover a time period of not less than 20 years. The probability of occurrence for each combination of significant wave height and mean period of the representative wave scatter diagram at the operational site of the terminal.

7.5.3 Calculation of Wave Load RAO's

The wave load RAO's with respect to the wave-induced bending moments, shear forces, motions, accelerations and hydrodynamic pressures can then be predicted by vessel motion calculation for a selected representative loading condition.

7.5.4 Generation of Stress Spectrum

The stress spectrum for each critical structural detail (spot) may be generated by performing a structural analysis accounting for all the wave loads separately for each individual wave group. For this purpose, the 3D structural models specified in 3-5/9 may be used for determining structural responses. The additional secondary and tertiary stresses are also to be considered.

7.5.5 Cumulative Fatigue Damage and Fatigue Life

Based on the stress spectrum and wave scatter diagram established above, the cumulative fatigue damage and the corresponding fatigue life can be estimated by the Palmgren-Miner linear damage rule.

7.7 Independent Cargo Tank Structures

Proportions and scantlings of structural members where deemed necessary may have to be investigated to improve the fatigue strength especially for type B and C independent tanks made of higher strength material and aluminum alloys.

9 Calculation of Structural Responses

9.1 Methods of Approach and Analysis Procedures

Maximum stresses in the structure are to be determined by performing structural analyses as outlined below. Guidelines on structural idealization, load application, and structural analysis are given in Chapter 3, Appendix 5.

In general, the strength assessment is to be focused on the results obtained from structures in the mid hold of a three hold length model. However, the deck transverse, the side transverse and the horizontal and the vertical webs on transverse bulkheads are to be assessed using the end holds of a three hold length model as well.

9.3 3D Finite Element Models

To determine the load distribution in the structure, a simplified three-dimensional finite element model, representing usually three bays of tanks within $0.4L$ amidships, is required.

For hull structures beyond $0.4L$ amidships, the same 3D model may be used with modifications to the structural properties and the applied loads, provided that the structural configurations are considered as representative of the location under consideration.

9.5 Local Structural Models

Local 3D fine mesh model are required to:

- Determine the stress distribution in major supporting structures, particularly at intersections of two or more structural members and/or
- Examine stress concentrations such as at bracket toes of main supporting members, at openings in way of critical locations, at intersections of longitudinals with transverses, at cut outs and at tank supports and chocks.

9.7 Load Cases

When performing structural analysis, the combined load cases specified in 3-3/9.1 are to be considered. In general, the structural responses for the still-water conditions are to be calculated separately to establish reference points for assessing the wave-induced responses. Additional load cases may be required for special loading patterns and unusual design functions, such as sloshing loads, as specified in 3-3/11 and 3-3/13. Additional load cases may also be required for hull structures beyond the region of $0.4L$ amidships.

1 General Requirements

1.1 General

The structural configurations, stiffening systems and design scantlings of the hull structures located beyond 0.4L amidships, including the forebody, aft end and machinery spaces, are to be in compliance with this Section and 5C-2-2/17 of the *Marine Vessel Rules*. In accordance with 3-2-2/5.1 of the *Marine Vessel Rules*, the thickness of the plating between the amidships 0.4L and the end 0.1L may be gradually tapered. However, the thickness need not be greater than the thickness required for the side shell plating amidships.

1.3 Structures within the Cargo Space Length (1 June 2014)

The scantlings of longitudinal structural members and elements in way of cargo spaces beyond the 0.4L amidships may be gradually reduced toward the peak bulkhead, provided that the hull girder section modulus complies with 3-4/3.5 and that the strength of the structure satisfies 3-4/7 through 3-4/17 and the material yielding, buckling and ultimate strength criteria specified in 3-5/3 and 3-5/5.

The scantlings of main supporting members in way of the cargo space length beyond 0.4L amidships are to comply with the requirements of 3-4/11. Where the structural configuration is different from that amidships due to the hull form of the vessel, additional evaluation is to be performed. The structural evaluation using the actual configuration is to be carried out to verify that the arrangement of openings necessary for access, ventilation, fabrication, etc. is satisfactory.

3 Forebody Side Shell Structure

In addition to the requirements specified in other relevant sections of the *Marine Vessel Rules*, the scantlings of the structure forward of 0.4L amidships are also to satisfy the requirements in 3-6/3.1, 3-6/3.3 and 3-6/3.5 below.

The nominal design corrosion values in the forepeak tank may be taken as 1.5 mm in determining design scantlings.

3.1 Side shell Plating (1 June 2014)

3.1.1 Plating Forward of Forepeak Bulkhead

The net thickness of the side shell plating forward of the forepeak bulkhead is to be not less than t_1 , t_2 and t_3 specified below.

$$t_1 = 0.73s(k_1p/f_1)^{1/2} \text{ in mm (in.)}$$

$$t_2 = 0.73s(k_2p/f_2)^{1/2} \text{ in mm (in.)}$$

$$t_3 = 0.73sk(k_3k_4p_b/f_3)^{1/2} \text{ in mm (in.)}$$

for side shell and bow plating above *LWL* in the region from the forward end to the forepeak bulkhead

where

- s = spacing of stiffeners, in mm (in.)
- k_1 = 0.342 for longitudinally and $0.50k^2$ for transversely stiffened plating
- k_2 = $0.50k^2$ for longitudinally and 0.342 for transversely stiffened plating
- k_3 = 0.50
- k_4 = 0.74
- k = $(3.075(\alpha)^{1/2} - 2.077)/(\alpha + 0.272)$, (1 ≤ α ≤ 2)
 = 1.0 (α > 2)
- α = aspect ratio of the panel (longer edge/shorter edge)
- f_1 = $0.65 S_m f_y$, in N/cm² (kgf/cm², lbf/in²) in the longitudinal direction
- f_2 = $0.85 S_m f_y$, in N/cm² (kgf/cm², lbf/in²) in the transverse (vertical) direction
- f_3 = $0.85 S_m f_y$, in N/cm² (kgf/cm², lbf/in²)
- p = nominal pressure $|p_i - p_e|$, in N/cm² (kgf/cm², lbf/in²), as specified in 3-3/Table 3 at the lower edge of each plate amidships with the following modifications
 - i)** A_i is to be calculated at the forward or aft end of the tank, whichever is greater
 - ii)** A_e is to be calculated at the center of the panel in accordance with 3-3/5.5.3, using L.C.7 with $k_{jo} = 1.0$ and x_o located amidships
 - iii)** B_e is to be calculated at 0.05L from FP in accordance with 3-3/5.5 ($p_s + k_u p_d$, full draft, heading angle = 0, $k_u = 1.1$)
- p_b = maximum bow pressure = $k_u p_{bij}$
- k_u = 1.1
- p_{bij} = nominal bow pressure, as specified in 3-3/15.1.1, at the center of the supported panel under consideration, in N/cm² (kgf/cm², lbf/in²)

S_m and f_y as defined in 3-4/7.3.1.

3.1.2 Plating between Forepeak Bulkhead and 0.3L from FP (1 June 2014)

Within the forepeak bulkhead and the 0.3L from FP, the side shell plating is to be not less than as given in 3-6/3.1.1 with B_e calculated at the actual location and with the following permissible stress.

$$\begin{aligned}
 f_1 &= \text{permissible bending stress in the longitudinal direction, in N/cm}^2 \text{ (kgf/cm}^2 \text{, lbf/in}^2\text{)} \\
 &= 0.43S_m f_y \quad \text{At } 0.3L \text{ from AP, for } L \geq 190 \text{ m (623 ft)} \\
 &= 0.60S_m f_y \quad \text{At fore peak bulkhead location, for } L \geq 190 \text{ m (623 ft)}
 \end{aligned}$$

Linear interpolation is to be used for the intermediate location.

$$\begin{aligned}
 &= [0.60 + 0.10 (190 - L)/40] S_m f_y \quad \text{for } L < 190 \text{ m (623 ft)} \\
 f_2 &= \text{permissible bending stress in the transverse direction, in N/cm}^2 \text{ (kgf/cm}^2 \text{, lbf/in}^2\text{)} \\
 &= 0.85S_m f_y
 \end{aligned}$$

3.3 Side Frames and Longitudinals

3.3.1 Side Frames and Longitudinals Forward of Forepeak Bulkhead (1 June 2014)

The net section modulus of side longitudinals and frames in association with the effective plating to which they are attached, is to be not less than that obtained from the following equation:

$$SM = M / f_{bi} \quad \text{in cm}^3 \text{ (in}^3\text{)}$$

$$M = 1000ps\ell^2 / k \quad \text{in N-cm (kgf-cm, lbf-in)}$$

where

$$k = 12 \text{ (12, 83.33)}$$

p = nominal pressure $|p_i - p_e|$, in N/cm^2 (kgf/cm^2 , lbf/in^2), as specified in 3-3/Table 3 with the following modifications.

- i) A_{ii} is to be calculated at the forward or aft end of the tank, whichever is greater. Between $0.3L$ and $0.25L$ aft of the FP the internal pressure need not be greater than that obtained amidships.
- ii) A_e is to be calculated in accordance with 3-3/5.5.3 using L.C.7 with $k_{fo} = 1.0$ and x_o located amidships.
- iii) B_e is to be calculated in accordance with 3-3/5.5 ($p_s + k_u p_d$, full draft, heading angle = 0, $k_u = 1.1$), with the distribution of p_p as shown in 3-6/Figure 1, at the side longitudinal and frame under consideration.

$$f_{bi} = 0.85 S_m f_y \text{ in N/cm}^2 \text{ (kgf/cm}^2 \text{, lbf/in}^2\text{)}$$

S_m and f_y are as defined in 3-4/7.3.1.

s and ℓ are as defined in 3-4/7.5.

For side longitudinal/stiffener in the region forward of the forepeak bulkhead and above LWL , the section modulus is not to be less than obtained from the above equation based on $p = p_b$, $f_b = 0.95 S_m f_y$ and $k = 16$ (16, 111.1), where p_b is as defined in 3-6/3.1 above.

FIGURE 1
 Transverse Distribution of p_d

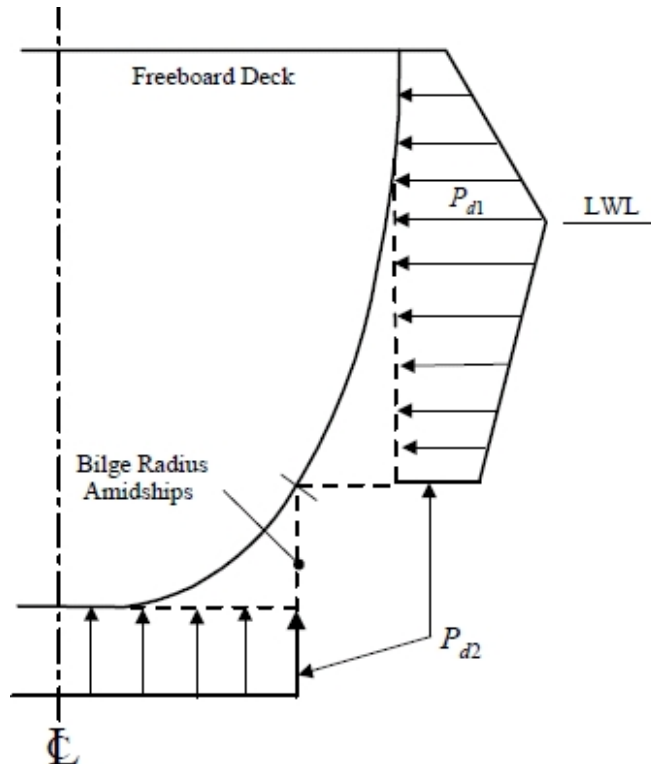

3.3.2 Side Frames and Longitudinals between Forepeak Bulkhead and 0.3L from FP (1 June 2014)

Aft of the forepeak bulkhead and forward of 0.3L from the FP, the side frames and longitudinals are to be not less than as given in 3-4/9.7 with B_e calculated at the actual location and with the following permissible stress.

$$\begin{aligned}
 f_{bi} &= \text{permissible bending stress, in N/cm}^2 \text{ (kgf/cm}^2, \text{ lbf/in}^2\text{)} \\
 &= 0.75 S_m f_y && \text{within } 0.4L \text{ amidships} \\
 &= 0.85 S_m f_y && \text{Forepeak bulkhead}
 \end{aligned}$$

Linear interpolation is to be used for the intermediate location.

3.5 Side Transverses and Stringers in Forebody

The requirements of the Subparagraphs below apply to the region forward of the cargo spaces where single side skin construction is used.

3.5.1 Section Modulus

The net section modulus of side transverse and stringer in association with the effective side shell plating is not to be less than obtained from the following equation:

$$SM = M / f_b \quad \text{in cm}^3(\text{in}^3)$$

3.5.1(a) Longitudinally Framed Side Shell

For side stringer

$$M = 1000c_1c_2 \quad ps\ell_t\ell_s/k \quad \text{in N-cm (kgf-cm, lbf-in)}$$

For side transverse, M is not to be less than M_1 or M_2 , whichever is greater.

$$M_1 = 1000c_3ps\ell_t^2(1.0 - c_4\phi)/k \text{ in N-cm (kgf-cm, lbf-in)}$$

$$M_2 = 850p_1s\ell_{t1}^2/k \text{ in N-cm (kgf-cm, lbf-in)}$$

where

$$k = 0.12 \text{ (0.12, 0.446)}$$

$$c_1 = 0.125 + 0.875\phi, \text{ but not less than 0.3}$$

Coefficients c_2 , c_3 and c_4 are given in the tables below.

Coefficient c_2

<i>Number of Side Stringers Between Platforms (flats)</i>	<i>No Stringer</i>	<i>One Stringer</i>	<i>More than one Stringer</i>
Top Stringer	0.0	0.90	0.70
Stringers Between Top and Lowest Stringers			0.75
Lowest Stringer			0.80

Coefficient c_3

<i>Number of Side Stringers Between Platforms (flats)</i>	<i>No Stringer</i>	<i>One Stringer</i>	<i>More than one Stringer</i>
Transverse above Top Stringer	0.85	0.55	0.55
Transverse Between Top and Lowest Stringers		—	0.64
Transverse Below Lowest Stringer		0.68	0.68

Coefficient c_4

<i>Number of Side Stringers Between Platforms (flats)</i>	<i>No Stringer</i>	<i>One Stringer</i>	<i>More than one Stringer</i>
Transverses	0.0	0.75	0.80

- p = nominal pressure, $|p_i - p_e|$, in kN/m^2 (tf/m^2 , Ltf/ft^2), over the side transverses using the same load cases as specified in 3-3/Table 3 for side transverses with the following modifications.
- i)* A_e is to be considered for case “a” and calculated in accordance with 3-3/5.5.3 using L.C.7 with $k_{\rho_o} = 1.0$ and x_o located amidships
 - ii)* B_e is to be calculated in accordance with 3-3/5.5 ($p_s + k_u p_d$, full draft, heading angle = 0, $k_u = 1$) with the distribution of p_d as shown in 3-6/3.3.1 FIGURE 1. B_i , A_e and B_e may be taken at the center of the side shell panel under consideration.
- p_1 = nominal pressure, $|p_i - p_e|$, in kN/m^2 (tf/m^2 , Ltf/ft^2), using the same load cases as specified in 3-3/Table 3 for side transverses with the following modifications.
- i)* A_e is to be considered for case “a” and calculated in accordance with 3-3/5.5.3 using L.C.7 with $k_{\rho_o} = 1.0$ and x_o located amidships
 - ii)* B_e is to be calculated in accordance with 3-3/5.5 ($p_s + k_u p_d$, full draft, heading angle = 0, $k_u = 1$) with the distribution of p_d as shown in 3-6/3.3.1 FIGURE 1. B_i , A_e and B_e calculated at the midspan ℓ_{s1} (between side stringers or between side stringer and platform, flat as shown in 3-6/3.5.4 FIGURE 2) of the side transverse under consideration.

For side transverses

- s = sum of half distances, in m (ft), between side transverse under consideration and adjacent side transverses or transverse bulkhead

For side stringers

- $s = 0.45\ell_s$
 $\phi = 1/(1 + \alpha)$
 $\alpha = 1.33(I_t/I_s)(\ell_s/\ell_s)$

where

- I_t = moment of inertia, in cm^4 (in^4) (with effective side plating), of side transverse. I_t is to be taken as average of those at the middle of each span ℓ_{t1} between side stringers or side stringer and platform (flat), clear of the bracket
- I_s = moment of inertia, in cm^4 (in^4) (with effective side plating), of side stringer at the middle of the span ℓ_{s1} clear of the bracket
- ℓ_t, ℓ_s = spans, in m (ft), of the side transverse (ℓ_t) and side girder (ℓ_s) under consideration as shown in 3-6/Figure 2
- ℓ_{t1} = span, in m (ft), of side transverse under consideration between stringers, or stringer and platform (flat), as shown in 3-6/3.5.4 FIGURE 2

When calculating α , if more than one side transverse or stringer is fitted and they are not identical, average values of I_t and I_s within side shell panel (panel between transverse bulkheads and platforms, flats) are to be used.

- f_b = permissible bending stress, in N/cm^2 (kgf/cm^2 , lbf/in^2)
 $= 0.75 S_m f_y$

S_m and f_y are as defined in 3-4/7.3.1.

The bending moment for side transverse below stringer (or below the platform if no stringer is fitted) is not to be less than 80% of that for side transverse above stringer (or above platform if no stringer is fitted).

3.5.1(b) Transversely Framed Side Shell

For side transverse

$$M = 1000c_1ps\ell_t\ell_s/k \text{ in N-cm (kgf-cm, lbf-in)}$$

For side stringer, M is not to be less than M_1 or M_2 , whichever is greater

$$M_1 = 1000c_2ps\ell_s^2(1.0 - c_3\phi_1)/k \text{ in N-cm (kgf-cm, lbf-in)}$$

$$M_2 = 1100p_1\ell_{s1}/k \text{ in N-cm (kgf-cm, lbf-in)}$$

where

$$k = 0.12 \text{ (0.12, 0.446)}$$

$$c_1 = 0.10 + 0.7\phi_1, \text{ but not to be taken less than 0.085}$$

If no side transverses are fitted between transverse bulkheads

$$c_2 = 1.1$$

$$c_3 = 0$$

If side transverses are fitted between transverse bulkheads

$$c_2 = 0.8$$

$$c_3 = 0.8$$

p = nominal pressure, $|p_i - p_e|$, in kN/m^2 (tf/m^2 , Ltf/ft^2), over the side stringers using the same load cases as specified in 3-3/Table 3 for side transverses in lower wing tank. A_u , A_e and B_e may be taken at the center of the side shell panel under consideration with the following modifications

- i) A_e is to be calculated in accordance with 3-3/5.5.3 using L.C.7 with $k_{fo} = 1.0$ and x_o located amidships
- ii) B_e is to be calculated in accordance with 3-3/5.5 ($p_s + k_u p_d$, full draft, heading angle = 0, $k_u = 1$) with the distribution of p_d as shown in 3-6/3.3.1 FIGURE 1.

p_1 = nominal pressure, $|p_i - p_e|$, in kN/m^2 (tf/m^2 , Ltf/ft^2), using the same load cases as specified in 3-3/Table 3 for side transverses in lower wing tank, with A_u , A_e and B_e calculated at the midspan ℓ_{s1} (between side transverses or between side transverse and transverse bulkhead as shown in 3-6/3.5.4 FIGURE 2) of the side stringer under consideration, with the following modifications.

- i) A_e is to be calculated in accordance with 3-3/5.5.3 using L.C.7 with $k_{fo} = 1.0$ and x_o located amidships
- ii) B_e is to be calculated in accordance with 3-3/5.5 ($p_s + k_u p_d$, full draft, heading angle = 0, $k_u = 1$) with the distribution of p_d as shown in 3-6/3.3.1 FIGURE 1.

For side stringers

s = sum of half distances, in m (ft), between side stringer under consideration and adjacent side stringers or platforms (flats)

For side transverses

$$s = 0.45\ell_t$$

$$\Phi_1 = \alpha/(1 + \alpha)$$

ℓ_{s1} = span, in m (ft), of the side stringer under consideration between side transverses or side transverse and transverse bulkhead, as shown in 3-6/3.5.4 FIGURE 2

$$f_b = \text{permissible bending stress, in N/cm}^2(\text{kgf/cm}^2, \text{lbf/in}^2)$$

$$= 0.75 S_m f_y$$

S_m and f_y are as defined in 3-4/7.3.1.

ℓ_t, ℓ_s and α are as defined in 3-6/3.5.1(a) above.

3.5.2 Sectional Area of Web

The net sectional area of the web portion of the side transverse and side stringer is not to be less than obtained from the following equation:

$$A = F/f_s$$

3.5.2(a) Longitudinally Framed Side Shell

For side stringer

$$F = 1000kc_1p\ell_s \text{ in N (kgf, lbf)}$$

For side transverse, F is not to be less than F_1 or F_2 whichever is greater

$$F_1 = 850kc_2p\ell_s(1.0 - c_3\Phi - 2h_e/\ell) \text{ N (kgf, lbf)}$$

$$F_2 = 1700kc_2p_1s(0.5\ell_1 - h_e) \text{ N (kgf, lbf)}$$

where

$$k = 0.5 (0.5, 1.12)$$

Coefficients c_1, c_2 and c_3 are given in the tables below.

Coefficient c_1

<i>Number of Side Stringers Between Platforms (flats)</i>	<i>No Stringer</i>	<i>One Stringer</i>	<i>More than one Stringer</i>
Stringers	0.0	0.52	0.40

Coefficient c_2

<i>Number of Side Stringers Between Platforms (flats)</i>	<i>No Stringer</i>	<i>One Stringer</i>	<i>More than one Stringer</i>
Transverses Above Top Stringer	1.0	0.9	0.9
Transverse Between Top and Lowest Stringers		—	0.95
Transverse Below Lowest Stringer		1.0	1.0

Coefficient c_3

<i>Number of Side Stringers Between Platforms (flats)</i>	<i>No Stringer</i>	<i>One Stringer</i>	<i>More than one Stringer</i>
Transverses	0.0	0.5	0.6

- ℓ = span, in m (ft), of the side transverse under consideration between platforms (flats), as shown in 3-6/3.5.4 FIGURE 2
- ℓ_1 = span, in m (ft), of the side transverse under consideration between side stringers or side stringer and platform (flat), as shown in 3-6/3.5.4 FIGURE 2
- h_e = length, in m (ft), of the end bracket of the side transverse, as shown in 3-6/3.5.4 FIGURE 2

To obtain F_1 , h_e is equal to the length of the end bracket at the end of span ℓ of side transverse, as shown in 3-6/3.5.4 FIGURE 2.

To obtain F_2 , h_e is equal to the length of the end bracket at the end of span ℓ_1 of side transverse, as shown in 3-6/3.5.4 FIGURE 2.

$$f_s = \text{permissible shear stress, in N/cm}^2 \text{ (kgf/cm}^2, \text{ lbf/in}^2\text{)}$$

$$= 0.45 S_m f_y$$

S_m and f_y are as defined in 3-4/7.3.1.

p, p_1, ϕ and s are as defined in 3-6/3.5.1(a) above.

The shear force for the side transverse below the lowest stringer (or below the platform if no stringer is fitted), is not to be less than 110% of that for the side transverse above the top stringer (or above the platform if no stringer is fitted).

3.5.2(b) Transversely Framed Side Shell

For side transverse

$$F = 850kc_1p\ell s \text{ in N (kgf, lbf)}$$

For side stringer, F is not to be less than F_1 or F_2 whichever is greater

$$F_1 = 1000kp\ell s(1.0 - 0.6\phi_1 - 2h_e/\ell) \text{ in N (kgf, lbf)}$$

$$F_2 = 2000kp_1s(0.5\ell_1 - h_e) \text{ in N (kgf, lbf)}$$

where

- $k = 0.5$ (0.5, 1.12)
 $c_1 = 0.1 + 0.7\phi_1$, but not to be taken less than 0.2
 $\ell =$ span, in m (ft), of the side stringer under consideration between transverse bulkheads as shown in 3-6/3.5.4 FIGURE 2
 $\ell_1 =$ span, in m (ft), of the side stringer under consideration between side transverses or side transverse and bulkhead, as shown in 3-6/3.5.4 FIGURE 2
 $h_e =$ length, in m (ft), of the end bracket of the side stringer under consideration as shown in 3-6/3.5.4 FIGURE 2

To obtain F_1 , h_e is equal to the length of the end bracket at the end of span ℓ of the side stringer, as shown in 3-6/3.5.4.

To obtain F_2 , h_e is equal to the length of the end bracket at the end of span ℓ_1 of the side stringer, as shown in 3-6/3.5.4 FIGURE 2.

$$\begin{aligned}
 f_s &= \text{permissible shear stress, in N/cm}^2 \text{ (kgf/cm}^2, \text{ lbf/in}^2\text{)} \\
 &= 0.45 S_m f_y
 \end{aligned}$$

S_m and f_y are as defined in 3-4/7.3.1.

p , p_1 , ϕ_1 and s are as defined in 3-6/3.5.1(a) above.

3.5.3 Depth of Transverses and Stringers

The depths of side transverses and stringers, d_w , are neither to be less than obtained from the following equations nor to be less than 2.5 times the depth of the slots respectively.

3.5.3(a) Longitudinally Framed Shell

For side transverse

If side stringer is fitted between platforms (flats)

$$\begin{aligned}
 d_w &= (0.08 + 0.80\alpha)\ell_t && \text{for } \alpha \leq 0.05 \\
 &= (0.116 + 0.084\alpha)\ell_t && \text{for } \alpha > 0.05
 \end{aligned}$$

and need not be greater than $0.2\ell_t$

If no side stringer is fitted between platforms (flats), d_w is not to be less than $0.2\ell_t$ or $0.06D$, whichever is greater.

For side stringer

$$\begin{aligned}
 d_w &= (0.42 - 0.9\alpha)\ell_s && \text{for } \alpha \leq 0.2 \\
 &= (0.244 - 0.0207\alpha)\ell_s && \text{for } \alpha > 0.2
 \end{aligned}$$

α is not to be taken greater than 8.0 to determine the depth of the side stringer.

ℓ_t, ℓ_s and α are as defined in 3-6/3.5.1(a) above.

D is as defined in 3-1-1/7 of the *Marine Vessel Rules*.

3.5.3(b) Transversely Framed Side Shell

For side stringer

If side transverse is fitted between transverse bulkheads

$$\begin{aligned}d_w &= (0.08 + 0.80\alpha_1)\ell_s && \text{for } \alpha_1 \leq 0.05 \\ &= (0.116 + 0.084\alpha_1)\ell_s && \text{for } \alpha_1 > 0.05\end{aligned}$$

and need not be greater than $0.2\ell_s$

If no side transverse is fitted between transverse bulkheads

$$d_w = 0.2\ell_s$$

For side transverse

$$\begin{aligned}d_w &= (0.277 - 0.385\alpha_1)\ell_t && \text{for } \alpha_1 \leq 0.2 \\ &= (0.204 - 0.205\alpha_1)\ell_t && \text{for } \alpha_1 > 0.2\end{aligned}$$

α_1 is not to be taken greater than 7.5 to determine the depth of the side transverse

where

$$\alpha_1 = 1/\alpha$$

ℓ_t , ℓ_s and α are as defined in 3-6/3.5.1(a) above.

3.5.4 Thickness of Transverses and Stringers

The net thickness of side transverse and stringer is not to be less than 9.5 mm (0.374 in.).

FIGURE 2
Definition of Spans

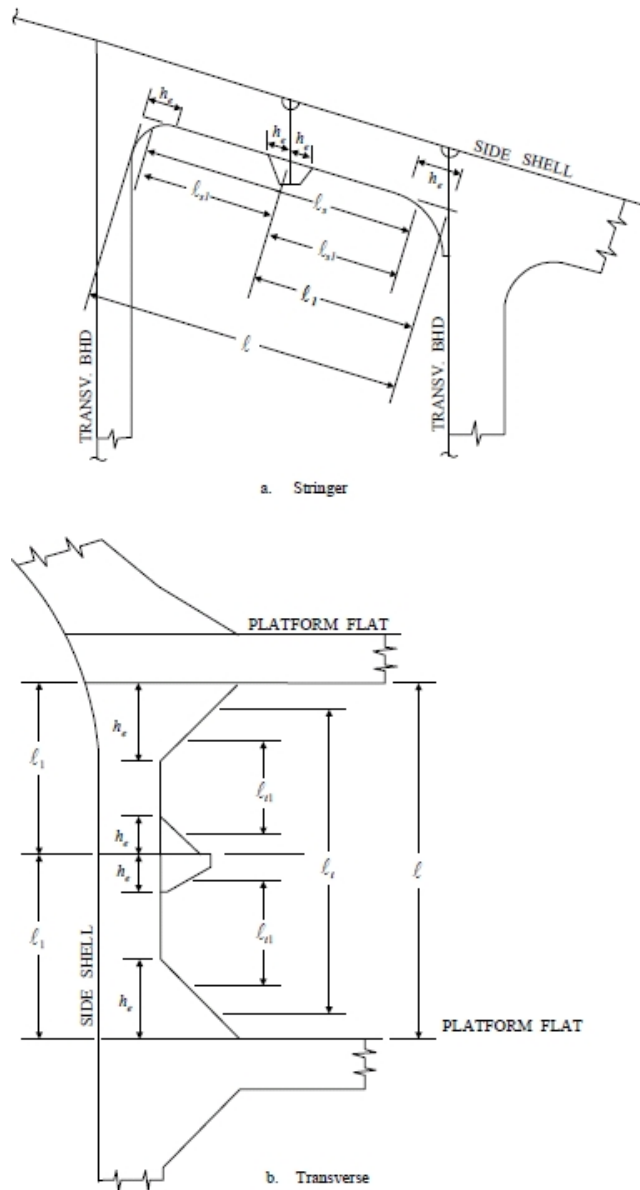

5 Transition Zone

In the transition zone between the forepeak and the No.1 cargo tank region due consideration is to be given to the proper tapering of major longitudinal members within the forepeak such as flats, decks, horizontal ring frames or side stringers aft into the cargo hold. Where such structure is in line with longitudinal members aft of the forward cargo tank bulkhead, this may be effected by fitting of large tapering brackets. These brackets are to have a taper of 4:1.

7 Forebody Strengthening for Slamming

(1 September 2012) Where the hull structure is subject to slamming as specified in 3-3/15, proper strengthening will be required as outlined below. For strengthening to account for bottom slamming, the requirements of this Subsection apply to vessels with a heavy ballast draft forward of less than 0.04L.

7.1 Bottom Slamming

7.1.1 Bottom Plating

When bottom slamming as specified in 3-3/15 is considered, the bottom structure in the region of the flat bottom forward of $0.25L$ measured from the FP is to be in compliance with the following requirement.

The net thickness of the flat bottom plating forward of $0.25L$ measured from the FP is not to be less than t obtained from the following equation:

$$t = 0.73s(k_2k_3p_s/f)^{1/2} \quad \text{in mm (in.)}$$

where

s = spacing of longitudinal or transverse stiffeners, in mm (in.)

k_2 = $0.5k^2$ for longitudinally stiffened plating

k_3 = 0.74

k = $(3.075(\alpha)^{1/2} - 2.077)/(\alpha + 0.272)$, $(1 \leq \alpha \leq 2)$
 = 1.0 $(\alpha > 2)$

α = aspect ratio of the panel (longer edge/shorter edge)

p_s = design slamming pressure = $k_u p_{si}$

For determination of t , the pressure p_s is to be taken at the center of the supported panel.

p_{si} = nominal bottom slamming pressure, as specified in 3-3/15.3.1, in N/cm² (kgf/cm², lbf/in²)

k_u = slamming load factor = 1.1

The maximum nominal bottom slamming pressure occurring along the vessel is to be applied to the bottom plating between the foremost extent of the flat of bottom and $0.125L$ from the FP. The pressure beyond this region may be gradually tapered to the longitudinal location where the nominal slamming pressure is calculated as zero.

f = permissible bending stress, in N/cm² (kgf/cm², lbf/in²)
 = $0.85 S_m f_y$

S_m and f_y are as defined in 3-4/7.3.1.

7.1.2 Bottom Longitudinals and Stiffeners

The section modulus of the stiffener including the associated effective plating on the flat bottom forward of $0.25L$ measured from FP is not to be less than obtained from the following equation:

$$SM = M/f_b \quad \text{in cm}^3 \text{ (in}^3\text{)}$$

$$M = 1000p_s s \ell^2 / k \quad \text{in N-cm (kgf-cm, lbf-in.)}$$

where

k = 16 (16, 111.1)

p_s = design slamming pressure = $k_u p_{si}$

For determination of M , the pressure p_s is to be taken at the midpoint of the span ℓ .

p_{si} = nominal bottom slamming pressure, as specified in 3-3/15.3.1, in N/cm² (kgf/cm², lbf/in²)

k_u = slamming load factor = 1.1

The maximum nominal bottom slamming pressure occurring along the vessel is to be applied to the bottom stiffeners between the foremost extent of the flat of bottom and 0.125L from the FP. The pressure beyond this region may be gradually tapered to the longitudinal location where the nominal slamming pressure is calculated as zero.

s = spacing of longitudinal or transverse stiffeners, in mm (in.)

ℓ = unsupported span of the stiffener, in m (ft)

f_b = 0.9 $S_m f_y$ for transverse and longitudinal stiffeners in the region forward of 0.125L measured from the FP

= 0.8 $S_m f_y$ for longitudinal stiffeners in the region between 0.125L and 0.25L measured from the FP

The effective breadth of plating, b_e , is as defined in 3-4/7.5.

Struts connecting the bottom and inner bottom longitudinals are not to be fitted.

7.1.3 Bottom Floors

The arrangements and scantlings of floors are to be adequate for bottom slamming loads, as specified in 3-3/15.

The spacing of floors forward of amidships need not be less than the spacing amidships.

7.3 Bowflare Slamming

When bowflare slamming as specified in 3-3/15.5 is considered, the side shell structure above the waterline in the region between 0.0125L and 0.25L from the FP is to be in compliance with the following requirements.

7.3.1 Side Shell Plating

The net thickness of the side shell plating between 0.0125L and 0.25L from the FP is not to be less than t_1 or t_2 , whichever is greater, obtained from the following equations:

$$t_1 = 0.73s(k_1 p_s / f_1)^{1/2} \text{ in mm (in.)}$$

$$t_2 = 0.73s(k_2 p_s / f_2)^{1/2} \text{ in mm (in.)}$$

where

p_s = maximum slamming pressure = $k_u p_{ij}$

p_{ij} = nominal bowflare slamming pressure, as specified in 3-3/15.5.1, at the center of the supported panel under consideration, in N/cm² (kgf/cm², lbf/in²)

k_u = slamming load factor = 1.1

f_1 = 0.85 $S_m f_y$ for side shell plating forward of 0.125L from the FP, in N/cm² (kgf/cm², lbf/in²)

$$\begin{aligned}
 &= 0.75 S_m f_y && \text{for side shell plating in the region between } 0.125L \text{ and } 0.25L \text{ from the} \\
 &&& \text{FP, in N/cm}^2 \text{ (kgf/cm}^2 \text{, lbf/in}^2\text{)} \\
 f_2 &= 0.85 S_m f_y, && \text{in N/cm}^2 \text{ (kgf/cm}^2 \text{, lbf/in}^2\text{)} \\
 k_1 &= 0.342 && \text{for longitudinally stiffened plating} \\
 &= 0.5k^2 && \text{for transversely stiffened plating} \\
 k_2 &= 0.5 && \text{for longitudinally stiffened plating} \\
 &= 0.342 && \text{for transversely stiffened plating}
 \end{aligned}$$

s , S_m , f_y and k are as defined in 3-6/7.1.1 above.

7.3.2 Side Longitudinals and Stiffeners

The section modulus of the stiffener, including the associated effective plating, is not to be less than obtained from the following equation:

$$SM = M / f_b \quad \text{in cm}^3 \text{ (in}^3\text{)}$$

$$M = 1000 p_s s \ell^2 / k \quad \text{in N-cm (kgf-cm, lbf-in.)}$$

where

$$k = 16 \text{ (16, 111.1)}$$

$$\ell = \text{unsupported span of the stiffener, in m (ft)}$$

$$p_s = \text{maximum slamming pressure, in N/cm}^2 \text{ (kgf/cm}^2 \text{, lbf/in}^2\text{), as defined in 3-6/7.3.1 at the midpoint of the span } \ell$$

s and f_b are as defined in 3-6/7.1 above

The effective breadth of plating, b_e , is as defined in 3-4/7.5.

7.3.3 Side Transverses and Side Stringers

For the region between $0.0125L$ and $0.25L$ from the FP, the net section modulus and sectional area requirements for side transverses and side stringers in 3-6/3.5 are to be met with the bowflare slamming pressure as specified in 3-3/15.5.1 and with the permissible bending stress of $f_b = 0.64 S_m f_y$ and the permissible shear stress of $f_s = 0.38 S_m f_y$.

9 Deck Structures in Forebody (1 September 2012)

9.1 Deck Plating

In addition to the requirements specified in other relevant sections of this Guide, the deck plating, longitudinal and beams forward of $0.25L$ from the FP are to meet the requirements for green water loads as specified below:

$$t_1 = 0.73s(k_1 p / f_1)^{1/2} \text{ mm (in.)}$$

$$t_2 = 0.73s(k_2 p / f_2)^{1/2} \text{ mm (in.)}$$

$$t_3 = 0.3s(S_m f_y / E)^{1/2} \text{ mm (in.) for main deck within } 0.1L \text{ from the FP}$$

where

$$s = \text{spacing of deck longitudinals, in mm (in.)}$$

$$k_1 = 0.342$$

$$k_2 = 0.50$$

$$p = p_{gi}, \text{ in N/cm}^2 \text{ (kgf/cm}^2, \text{ lbf/in}^2)$$

p_{gi} is nominal green water loading given in 3-3/15.7

The required thickness, t_3 , between 0.30L and 0.1L from the FP is to be obtained by linear interpolation between midship region deck thickness (3-4/9.5) and the t_3 value as specified above.

The net thickness, t_3 , may be determined based on S_m and f_y of the hull girder strength material required at the location under consideration.

$$f_1 = 0.50S_m f_y, \text{ in N/cm}^2 \text{ (kgf/cm}^2, \text{ lbf/in}^2) \quad \text{for main deck within 0.1L from the FP.}$$

$$f_1 = 0.60S_m f_y, \text{ in N/cm}^2 \text{ (kgf/cm}^2, \text{ lbf/in}^2) \quad \text{for forecastle deck}$$

$$f_2 = 0.80S_m f_y, \text{ in N/cm}^2 \text{ (kgf/cm}^2, \text{ lbf/in}^2)$$

The permissible stress, f_1 , for main deck between 0.25L and 0.1L from the FP is to be obtained by linear interpolation between midship region permissible stress (3-4/9.5) and the permissible stress at 0.1L from the FP, as specified above.

S_m , f_y and E are as defined in 3-4/7.3.1.

9.3 Deck Longitudinals/Beams

The net section modulus of each individual side or deck longitudinal, in association with the effective plating to which it is attached, is to be not less than obtained from the following equation:

$$SM = M / f_b \text{ cm}^3 \text{ (in}^3)$$

$$M = 1000ps\ell^2 / k \text{ N-cm (kgf-cm, lbf-in)}$$

where

$$k = 12 \text{ (12, 83.33)}$$

$$p = p_{gi}, \text{ in N/cm}^2 \text{ (kgf/cm}^2, \text{ lbf/in}^2)$$

p_{gi} is nominal green water loading given in 3-3/15.7

$$f_b = 0.70S_m f_y, \text{ in N/cm}^2 \text{ (kgf/cm}^2, \text{ lbf/in}^2), \quad \text{for main deck longitudinals}$$

$$= 0.80S_m f_y, \text{ in N/cm}^2 \text{ (kgf/cm}^2, \text{ lbf/in}^2), \quad \text{for main deck beams}$$

S_m , f_y , s and ℓ are as defined in 3-4/7.5.

Design and Analysis of Other Major Hull Structural Features**1 General (1 July 2022)**

The design and analysis criteria to be applied to the other pertinent features of the hull structure are to conform to this Guide or to recognized practices acceptable to ABS. For many floating liquefied gas terminals, the hull design will need to consider the interface between the position mooring system and the interface between deck-mounted (or above-deck) equipment modules and the hull structure. The interface structure is defined as the attachment zone of load transmission between the main hull structure and hull mounted equipment, such as topside module stools, crane pedestals and foundations, riser porches, flare boom foundation, gantry foundation, mooring and offloading equipment, etc. The zone includes components of the hull underdeck structures in way of module support stools and foundations, such as deck transverse web frames, deck longitudinals and upper parts of longitudinal and transverse bulkhead structures, as well as foundations of the hull-mounted equipment. These components of the interface structure should comply with the criteria in 3-7/9.

The basic scantlings in way of the hull interface structure are to be designed based on the first principle approach and meet the requirements of Section 3-2-1 of the *MOU Rules* strength criteria, the *ABS Requirements for Buckling and Ultimate Strength Assessment for Offshore Structures* and the *ABS Guide for the Fatigue Assessment of Offshore Structures*, or equivalent national industry standards recognized and accepted by ABS, such as API Standards. Welding design of hull interface structure connections is to be developed based on Section 3-2-6 of the *MOU Rules* or a direct calculation approach. Material grades for the above-deck interface structure are to be selected as per Section 3-1-4 of the *MOU Rules* requirements. The material grades for the hull structure components, such as deck and frame structures, are to be selected as per Part 3 of the *Marine Vessel Rules*.

Criteria applicable to the position mooring (e.g., turret) structure itself is given in Section 6-2-1 of the *FPI Rules*, and the above (or on) deck equipment or module structure is referred to in 4-1-7/5 of the *FPI Rules*.

The verification of the hull interface structure as defined above is to be performed using direct calculation of local 3-D hull interface finite element models, developed using gross scantlings and analyzed with load conditions and load cases described in the following sections.

3 Position Mooring Hull Interface

An FEM analysis of the interface between the position mooring system and hull structure is to be performed and submitted for review.

3.1 Turret or SPM Type Mooring System, External to the Hull Structure

If the mooring system is of the turret or SPM type, external to the hull, the following applies:

3.1.1 Fore End Mooring

The minimum extent of the model is from the fore end of the floating terminal, including the turret structure and its attachment to the hull, to a transverse plane after the aft end of the foremost cargo tank in the installation. The model can be considered fixed at the aft end of the model. The loads modeled are to correspond to the worst-case tank loads, seakeeping loads as determined for both the transit condition and the on-site design environmental condition (DEC), ancillary structure loads, and mooring and riser loads for the on-site DEC, where applicable. The design operating condition (DOC) may also need to be considered for conditions which may govern.

3.1.2 Aft End Mooring

The minimum extent of the model is from the aft end of the floating terminal, including the turret structure and its attachment to the hull structure, to a transverse plane forward of the fore end of the aft most cargo tank in the hull. The model can be considered fixed at the fore end of the model. The loads modeled are to correspond to the worst-case tank loads, seakeeping loads as determined for both the transit condition and the on-site design environmental condition (DEC), ancillary structure loads, and mooring and riser loads for the on-site DEC, where applicable.

3.3 Mooring System Internal to the Hull Structure (Turret Moored)

If the mooring arrangement is internal to the hull (turret-moored), the following applies:

3.3.1 Fore End Turret

The model is to extend from the fore end of the floating terminal to the after end of the cargo tank or hold aft of the one containing the turret. The model can be considered fixed at the aft end of the model. The loads modeled are to correspond to the worst-case tank loads, seakeeping loads as determined for either the transit condition or the on-site design environmental condition (DEC), ancillary structure loads, and mooring and riser loads for the on-site DEC, where applicable. The design operating condition (DOC) may also need to be considered for conditions which may govern.

3.3.2 Midship Turret

The model can be a 3-tank model similar to that described in 3-5/9.3 where the turret is located in the center tank of the model. Hull girder loads are to be applied to the ends of the model. The loads modeled are to correspond to the worst-case tank loads, seakeeping loads as determined for either the transit condition or the on-site design environmental condition (DEC), ancillary structure loads, and mooring and riser loads for the on-site DEC, where applicable. The design operating condition (DOC) may also need to be considered for conditions which may govern.

As a minimum, the following two cargo loading patterns that result in the worst load effects on the hull structure are to be considered:

- Maximum internal pressure for fully filled tanks adjacent to the hold containing the turret, with the other tanks empty and minimum external pressure, where applicable. (See 3-7/3.3 FIGURE 1)
- Empty tanks adjacent to the hold containing the turret, with the other tanks full and maximum external pressure, where applicable. (See 3-7/3.3 FIGURE 2)

The interface structure is to be assessed for yielding, buckling and fatigue strength, and should include all structural members and critical connections within the hold containing the turret as well as the hold boundaries and their attachments.

FIGURE 1
Loading Pattern 1 with 2/3 Scantling Draft

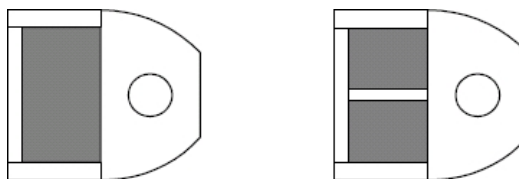
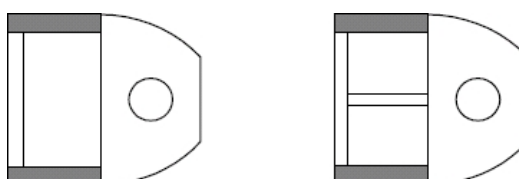

FIGURE 2
Loading Pattern 2 with Scantling Draft



3.5 Spread Moored Installations

The local foundation structure and hull structure are to be checked for the given mooring loads and hull structure loads, where applicable, using an appropriate FEM analysis. The mooring loads to be used in the analysis are to be based on the on-site design environmental condition (DEC) for hull structure, and the mooring loads for the on-site DEC and breaking strength of the mooring lines. The design operating condition (DOC) may also need to be considered for conditions which may govern.

5 Hull Mounted Equipment Interface

5.1 Topside Module Support Stools and Hull Underdeck Structures

The topside module support stools and hull underdeck structures in way of module support stools, such as deck transverse webs, deck longitudinals, longitudinal and transverse bulkheads, are to be assessed for the most unfavorable load combinations of topside stool reactions and hull structure loads, where applicable, using an appropriate FEM analysis. The load combinations of topside stool reactions and hull structure loads are to be consistent with those assumed in the module analysis (refer to 3-7/11.1). The finite element model extent is to be sufficiently large to minimize the cut boundary effects. The openings in way of critical areas are to be incorporated into the FEM model to investigate their effects. The loads for the on-site design operating condition (DOC), on-site design environmental condition (DEC) and transit condition are to be taken into account. Topside production and support systems are to be empty in transit condition. Special attention is to be given to the cutouts in deck transverse webs in way of topside module stools. The strength analysis for the typical cutout with the maximum topside stool reactions using a local fine mesh FEM model is to be carried out and submitted for review.

5.3 Other Hull Mounted Equipment Foundation Structures

Other hull mounted equipment foundations, such as crane pedestals and foundations, riser porches, flare boom foundations, gantry foundations, offloading equipment foundations, etc., and hull vessel structure in way of the foundations are to be checked for the given functional loads, environmental loads and hull structure loads, where applicable, using an appropriate FEM analysis. The finite element model extent is to be sufficiently large to minimize the cut boundary effects. Openings such as cutouts in way of critical areas are to be incorporated into the FEM model. The loads for the on-site design operating condition (DOC), on-site design environmental condition (DEC) and transit condition are to be taken into account in the analysis. All equipment is to be in the stowed position for the transit condition.

7 Loads

7.1 Load Conditions

For all conditions, the primary hull girder load effects are to be considered, where applicable.

7.1.1 Site Design Environmental Condition (DEC)

For non-disconnectable floating terminals:

- Site DEC with hull design return period, and severe storm functional dead and live loads, as applicable, with $\frac{1}{3}$ stress increase allowable (i.e., $0.8*f_y$)

For disconnectable floating terminals:

- Site Disconnectable Environmental Condition (DISEC), Client-specified site year return loads (See 2-2/1 of this Guide), and severe storm functional, dead and live loads (i.e., excluding tropical cyclones), as applicable, with $\frac{1}{3}$ stress increase allowable (i.e., $0.8*f_y$)

For the DEC and DISEC load conditions, the following assumptions are applicable:

- Topside Production Facility modules are in wet condition for all site conditions and in dry conditions for unrestricted service and transit conditions.
- Cranes are in stowed position
- Mooring loads in the most severe hull loading condition are determined from the site mooring load analysis for the following conditions:
 - All lines are intact
 - One line is damaged
 - For each individual line and associated fairlead, chock, chain stopper etc., the strength is to be assessed under the breaking strength of the line/chain with a Utilization Factor, $UF = 0.8$ for component stress, 0.9 for Von Mises element stress and 0.8 for buckling stress, in the case that the mooring loads in the above two conditions are not available.

Note:

FE analysis requirements for the position mooring/hull interface described in 3-7/3 are to be met. In addition for the internal turret, the longitudinal strength calculations (i.e., Hull Girder longitudinal bending and shear strength and IACS buckling strength checks (UR S11.5), as per 3-4/3 of this Guide and Appendix 3-2-A4 of the *Marine Vessel Rules*, for the hull girder section in way of the internal turret), for all applicable conditions, are to be submitted for review and approval.

7.1.2 Site Design Operating Condition (DOC)

Site DOC with maximum functional live loads under site operation without $\frac{1}{3}$ stress increase allowable (i.e., $0.6*f_y$). Special consideration should be given to the following:

- Limiting environmental condition, specified by designer/operator, that would require suspension of normal operations, is to be minimum 1-year return as per this Guide.
- Deck support stools for topside production facility modules are in wet condition.
- Crane functional loads are as per API RP 2A and API Spec 2C Practices.
- Position mooring hull interface

7.1.3 Transit Condition

For transit (topside production facility in dry condition), it is the shipyard's and/or designer's responsibility to specify the design parameters for the transit condition. There are generally four approaches available:

- Specified maximum seasonal weather routing condition;
- Maximum 10-year return response based on the worst environmental conditions and associated wave scatter diagram along the transit route,
- Maximum 10-year return response based on a composite wave scatter diagram,
- North Atlantic service condition, with a minimum 10-year return period, using the IACS standard wave data where the transit route is not yet defined or finalized.

7.1.4 Damage Condition

Damaged Conditions (as applicable) with static deadweight and functional loads only, for a minimum 1-year return period DOC caused by accidental flooding.

7.3 Inertial Load Cases

The long-term and short-term DLP (Dominant Load Parameter) values can be calculated either using the ABS Eagle FLGT SEAS module or by using direct seakeeping/hydrodynamic calculations using 3D diffraction radiation program. The DLP values are to be selected for the most unfavorable structural response. Maximum accelerations are to be calculated at the center of gravity of the most forward and aft and midship topside production facility modules. The load cases are to be selected to maximize each of the following DLPs together with other associated DLP values.

- Max. Vertical Bending Moment
- Max. Shear Force
- Max. Vertical Acceleration
- Max. Lateral Acceleration
- Max. Roll

Alternatively, the number of load cases can be reduced by assuming that all maximum DLP values occur simultaneously, which is a conservative assumption.

7.5 Hull Girder Load Cases

As a minimum, the following two hull girder load cases are to be analyzed:

- Maximum hull girder sagging moment (i.e., generally full load condition)
- Maximum hull girder hogging moment (i.e., generally ballast, tank inspection or partial loading condition)

9 Acceptance Criteria

9.1 Yielding Checks (1 September 2012)

9.1.1 For DEC 100-Years Return Periods, Transit 10-Year Return Period and/or North Atlantic Loads

i) For one-stiffener spacing element size FE analysis:

$$f_e \text{ (Von Mises)} < 0.9f_y \quad \text{plate membrane stresses at element centroids}$$

$$f_{1x} \text{ (axial stress)} < 0.8f_y \quad \text{bar and beam elements}$$

$$f_{xy} \text{ (shear)} < 0.53f_y$$

- ii)* (2016) The effects of notches, stress risers and local stress concentrations are to be taken into account when considering load carrying elements. When stress concentrations are considered to be of high intensity in certain elements, the acceptable stress levels will be subject to special consideration. The following guidance may be used in such circumstances.

For local detail FE model analyses (localized highly stressed area, fine mesh element size, for example, less than 2 x plate thickness):

$$f_e \quad \text{small area} < 1.25S_m f_y$$

$$f_{lx} \quad \text{element stress} < 1.25S_m f_y$$

9.1.2 For DOC (Deadweight + Maximum Functional Loads), with 1-Year Minimum Return Period Loads

- i)* For one-stiffener spacing element size FE analysis:

$$f_e < 0.7f_y \quad \text{plate membrane stresses at element centroids}$$

$$f_{lx} < 0.6f_y \quad \text{bar and beam elements}$$

$$f_{xy} < 0.4f_y$$

Note:

These load cases often govern for benign environmental loads.

- ii)* (2016) For local detail FE model analyses (localized highly stressed area, fine mesh element size, for example, less than 2 x plate thickness):

$$f_e \quad \text{small area} < 0.97S_m f_y$$

$$f_{lx} \quad \text{element stress} < 0.97S_m f_y$$

9.1.3 For Damaged Condition

Same as above for a minimum 1-year return period, except for the following, as applicable:

- i)* For one-stiffener spacing element size FE analysis:

$$f_e < 0.9f_y \quad \text{plate membrane stresses at element centroids}$$

$$f_e < 0.8f_y \quad \text{bar and beam elements}$$

$$f_{xy} < 0.53f_y$$

- ii)* (2016) For local detail FE model analyses (localized highly stressed area, fine mesh element size, for example, less than 2 x plate thickness):

$$f_e \quad \text{small area} < 1.25S_m f_y$$

$$f_{lx} \quad \text{element stress} < 1.25S_m f_y$$

where

$$S_m = 1.0 \quad \text{for mild steel}$$

$$= 0.95 \quad \text{for Grade HT32 steel}$$

$$= 0.908 \quad \text{for Grade HT36 steel}$$

= 0.875 for Grade HT40 steel

For material grades other than the above, the allowable stresses will be specially considered.

9.3 Buckling Checks (1 July 2022)

ABS buckling criteria included in the latest edition of the *ABS Requirements for Buckling and Ultimate Strength Assessment for Offshore Structures* are to be used with the following:

- Buckling strength to be calculated using gross scantlings
- Utilization Factor, *UF*:

$UF = 0.8$ or $SF = 1.25$ for onsite DEC, transit condition and/or North Atlantic condition

$UF = 0.6$ or $SF = 1.67$ for onsite DOC

$UF = 0.8$ or $SF = 1.25$ for damage condition

UF determined on a case-by-case basis for other special conditions

9.5 Fatigue Calculations

9.5.1

The fatigue damage/life calculations are to be carried out as per the latest edition of the *ABS Guide for Fatigue Assessment of Offshore Structures*. The fatigue calculations are to be carried out for the intended design operating life of the installation. Where the external interface connections are subjected to water immersion, the S-N curves in seawater with (CP) Cathodic Protection or (FC) Free Corrosion are to be used, as applicable. If the simplified fatigue calculation approach is to be used and the long-term Weibull distribution parameter is not available for the hull interface, then a Weibull parameter is to be developed for the specific location under consideration.

The fatigue design factors for fatigue life for hull interface connections are to be in accordance with 3-7/9.5.1 TABLE 1 shown below:

TABLE 1
Fatigue Design Factors for Fatigue Life of Hull Interface Structures
(1 September 2012)

<i>Importance</i>	<i>Inspectable and Repairable</i>	
	<i>Yes</i>	<i>No</i>
Non-Critical	2	5
Critical	3	10

Note: “Critical” implies that failure of these structural items would result in the rapid loss of structural integrity and produce an event of unacceptable consequence.

9.5.2 Position Mooring Hull Interface

Structural members in way of the turret structure or other mooring structure are to be effectively connected to the adjacent structure in such a manner as to avoid hard spots, notches and other harmful stress concentrations.

Special attention is to be given to cutouts, bracket toes and abrupt changes of structural sections. These areas are considered to be critical to the vessel and are to be free of cracks. The effects of stress risers in these areas are to be determined and minimized.

The FE model used to perform the turret/hull integration strength analysis may also be used for the fatigue screening evaluation of the turret/hull interface structure to identify the critical fatigue details using the F or F2 Class S-N curves and appropriate safety factors. The refined stress analysis should be performed for the critical areas that fail to meet the screening, and the use of the hot spot approach as specified in the *ABS Guide for the Fatigue Assessment of Offshore Structures* is considered to be acceptable.

The fatigue cyclic loads are to correspond to the worst-case tank dynamic loads, seakeeping loads, inertia loads due to the vessel motion, and mooring and riser dynamic loads, where applicable. Different wave headings and vessel tank loading patterns should be considered and the fraction of the total time for each base wave heading and each tank loading pattern can be used directly.

The frequency difference between wave frequency stress response and low frequency stress response imposed by mooring lines and risers should be considered. Although the low frequency stress response has negligible effects on most hull structural details, it becomes significant and may have the dominant contribution to the fatigue damage of structural components in the mooring system, risers and their interface with the hull. When the wave frequency and low frequency stress responses are obtained separately, the method of simple summation of fatigue damages from the two frequency stress responses does not account for the coupling effects (i.e., the augmentation of the low frequency response by the wave frequency response is non-conservative and therefore should not be used).

There is an alternative method, which is both conservative and easy to use, that is known as the combined spectrum method. In this method, the stress spectra for the two frequency bands are combined. The RMS and the mean up-crossing frequency of the combined stress process are given, respectively, as follows:

$$\sigma_c = (\sigma_w^2 + \sigma_\ell^2)^{1/2}$$

$$f_{0c} = (f_{0w}^2 \sigma_w^2 + f_{0\ell}^2 \sigma_\ell^2)^{1/2} / \sigma_c$$

where

σ_w = RMS of the wave-frequency stress component

σ_ℓ = RMS of the low-frequency stress component

f_{0w} = mean up-crossing frequency of the wave-frequency stress component

$f_{0\ell}$ = mean up-crossing frequency of the low-frequency stress component

However, if both frequency components of stress range are significant, the above-mentioned combination method may be too conservative since the wave-frequency contribution is expected to dominate, thus controlling the mean up-crossing frequency of the combined stress process. To eliminate the conservatism, a correction factor given below can be applied to the calculated fatigue damage of the sea state:

$$\frac{f_{0p}}{f_{0c}} \left[\lambda_\ell^{(m/2)+1} \left(1 - \sqrt{\frac{\lambda_w}{\lambda_\ell}} \right) + \sqrt{\pi \lambda_\ell \lambda_w} \frac{m \Gamma(m/2 + 1/2)}{\Gamma(m/2 + 1)} \right] + \left(\frac{f_{0w}}{f_{0c}} \right) \lambda_w^{m/2}$$

where

$$\lambda_\ell = \sigma_\ell^2 / \sigma_c^2$$

$$\lambda_w = \sigma_w^2 / \sigma_c^2$$

$$f_{0p} = \left(\lambda_{\ell}^2 f_{\ell}^2 + \lambda_{\ell} \lambda_w f_{0w}^2 \delta_w^2 \right)^{1/2} \text{ with } \delta_w = 0.1$$

m = slope parameter of the S-N curve

$\Gamma(\)$ = complete gamma function

9.5.3 Hull Mounted Equipment Interface

The procedure for the fatigue evaluation of the turret/hull integration structure can also be applied to deck-mounted equipment interface structures in which the wave-induced hull girder loads, external hydrodynamic pressure, and inertia loads due to the vessel motion as well as the specified equipment fatigue loads should be taken into account.

Special attention is to be given to the cutouts in deck transverse webs in way of topside module stools. Where applicable, the detail fatigue evaluation for the typical cutout with the maximum topside stool dynamic reactions is to be carried out and submitted for review.

11 Modules on Deck

11.1 General (1 August 2023)

This Subsection is applicable where the optional notation **Topside Modules** is requested.

The structural strength design of deck modules on floating liquefied gas terminals is to be in accordance with 5B-3-3/5.3.1 through 5B-3-3/5.3.4 and 5B-3-3/5.3.6 of the *FPI Rules*, wherever applicable. The relative deformations among module supports (e.g., stools) and the rigidity of supports and hull/deck, as well as hull deformations, are to be included in the analysis if their effects on the module are significant.

The module structures above their supports are to be analyzed and shown explicitly on the drawings so that the construction of the module supports can be consistent with those assumed in the structural analysis. The module design reactions and conditions are to be assessed for the most unfavorable load combinations of topside stool reactions and hull structure loads. The design requirements for module supports are given in 5A-1-3/1.13 of the *FPI Rules* and 3-7/7 of this Guide.

Fatigue analysis of the modules on floating terminals is not required. However, fatigue analysis of the topside module/hull interface is required (see 3-7/9.5).

The structural fire protection aspects of the design of deck modules, including the arrangement of the hydrocarbon process area, are to be in accordance with Chapter 3, Section 8 of the *Facilities Rules*.

The designs of the piping system on the floating terminal deck are to comply with Part 4, Chapter 2 of the *MOU Rules* and applicable requirements of the *Facilities Rules*.

CHAPTER 3 Structural Design Requirements

APPENDIX 1 Guide for Fatigue Strength Assessment

1 General

1.1 Note

This Guide provides a designer oriented approach to fatigue strength assessment which may be used, for certain structural details, in lieu of more elaborate methods, such as spectral fatigue analysis. The term assessment is used here to distinguish this approach from the more elaborate analysis.

The criteria in this Guide are developed from various sources, including the Palmgren-Miner linear damage model, S-N curve methodologies, a long-term environment data of the North-Atlantic Ocean (Walden's Data), etc., and assume workmanship of commercial marine quality acceptable to the Surveyor. The capacity of structures to resist the fatigue is given in terms of fatigue damage to allow designers the maximum flexibility possible.

1.3 Applicability

The criteria in this Guide are specifically written for floating offshore liquefied gas terminals to which Chapter 3, Section 1 is applicable.

1.5 Loadings

The criteria have been written for ordinary wave-induced motions and loads. Other cyclic loadings, which may result in significant levels of stress ranges over the expected lifetime of the floating terminal, are also to be considered by the designer.

1.7 Effects of Corrosion

To account for the mean wastage throughout the service life, the total stress range calculated using the net scantlings (i.e., deducting nominal design corrosion values, see 3-2/Table 1) is modified by a factor C_f . See 3-A1/9.1.1.

1.9 Format of the Criteria

The criteria in this Guide are presented as a comparison of fatigue strength of the structure (capacity) and fatigue inducing loads (demands), in the form of a fatigue damage parameter, DM . The calculated fatigue damage, DM , is to be less than or equal to 1 for the design life of the floating terminal, which corresponds to a fatigue life of 20 years.

3 Connections to be Considered for the Fatigue Strength Assessment

3.1 General

These criteria have been developed to allow consideration of a broad variation of structural details and arrangements, so that most of the important structural details anywhere in the floating terminal can be subjected to an explicit (numerical) fatigue assessment using these criteria. However, where justified by comparison with details proven satisfactory under equal or more severe conditions, an explicit assessment can be exempted.

3.3 Guidance on Locations

As a general guidance for assessing fatigue strength for a floating liquefied gas terminal, the following connections and locations should be considered:

3.3.1 Connections of Longitudinal Stiffeners to Transverse Web/Floor and to Transverse Bulkhead

3.3.1(a) 2 to 3 selected side longitudinals in the region from the 1.1 draft to about $\frac{1}{3}$ draft in the midship region and also in the region between $0.15L$ and $0.25L$ from F.P. respectively

3.3.1(b) 1 to 2 selected longitudinals from each of the following groups:

Deck longitudinals, bottom longitudinals, inner bottom longitudinals and longitudinals on longitudinal bulkheads

For these structural details, the fatigue assessment is to be first focused on the flange of the longitudinal at the rounded toe welds of attached flat bar stiffeners and brackets, as illustrated for Class F item 2) and Class F2 item 1) in 3-A1/Table 1.

Then, the critical spots on the web plate cut-out, on the lower end of the stiffener as well as the weld throat are also to be checked for the selected structural detail. For illustration, see 3-A1/11.3.1 and 3-A1/11.3.2(a), 3-A1/11.3.2(b), and 3-A1/11.3.2(c).

Where the longitudinal stiffener end bracket arrangements are different on opposing sides of a transverse web, both configurations are to be checked.

3.3.2 Shell, Bottom, Inner Bottom or Bulkhead Plating at Connections to Webs or Floors (for Fatigue Strength of Plating)

3.3.2(a) 1 to 2 selected locations of side shell plating near the summer LWL amidships and between $0.15L$ and $0.25L$ from F.P. respectively

3.3.2(b) 1 to 2 selected locations in way of bottom and inner bottom amidships

3.3.2(c) 1 to 2 selected locations of lower strakes of longitudinal bulkhead amidships

3.3.3 Connections of the Slope Plate to Inner Bottom, Longitudinal Bulkhead and Inner Deck Plating

One selected location amidships at transverse web and between webs, respectively

For this structural detail, the value of f_R , the total stress range as specified in 3-A1/9.1, is to be determined from fine mesh F.E.M. analyses for the combined load cases.

3.3.4 Connections of Cofferdam Bulkhead Plating of a Cellular-type Construction to Inner Bottom, Longitudinal Bulkhead and Inner Deck Plating

1 to 2 selected locations in the midship region at vertical and horizontal webs

3.3.5 Connections of Hold Frame

Typical end connections of hold frames to the upper and lower wing tanks in cargo holds (see 3-A1/3.3.5 FIGURE 1 below).

FIGURE 1
Hold Frames

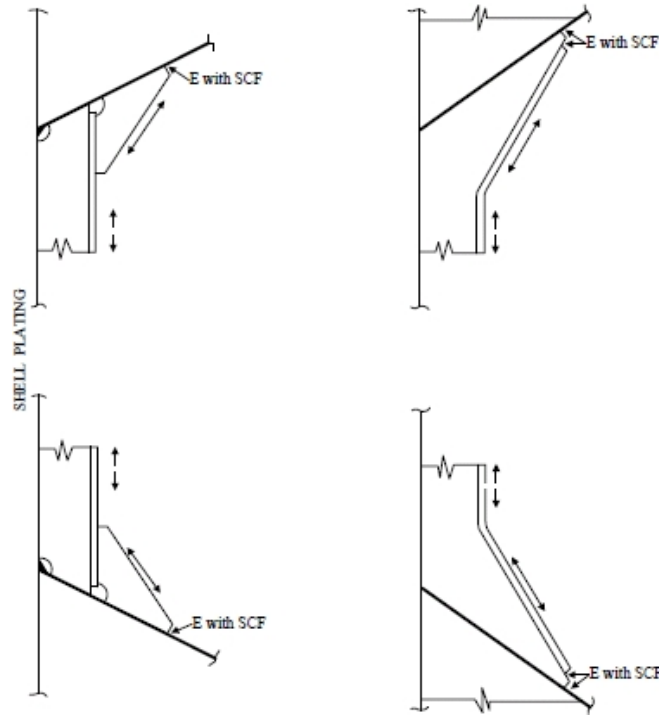

3.3.6 Connections of Slope Plate to Inner Bottom and Longitudinal Bulkhead Plating

One selected location amidships at transverse web (see 3-A1/3.3.6 FIGURE 2 below).

FIGURE 2
Connection between Inner Bottom and Hopper Tank Slope

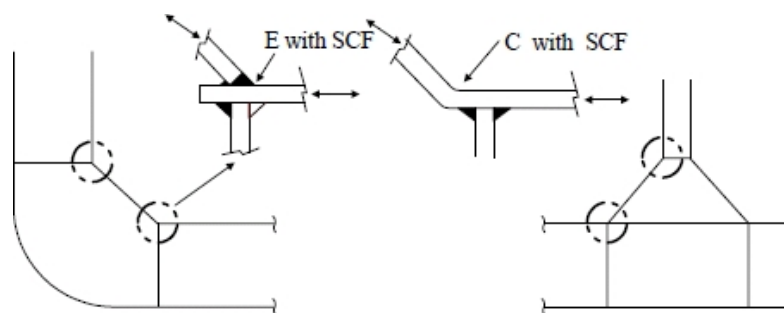

3.3.7 End Bracket Connections for Transverses

One (1) to two (2) selected locations in the midship region for each type of bracket configuration.

3.3.8 Hatch Corners of Dome Openings

Access openings, pipe penetrations and hatch corners of the opening for tank dome (see 3-A1/3.3.8 FIGURE 3 below).

**FIGURE 3
 Hatch Corner**

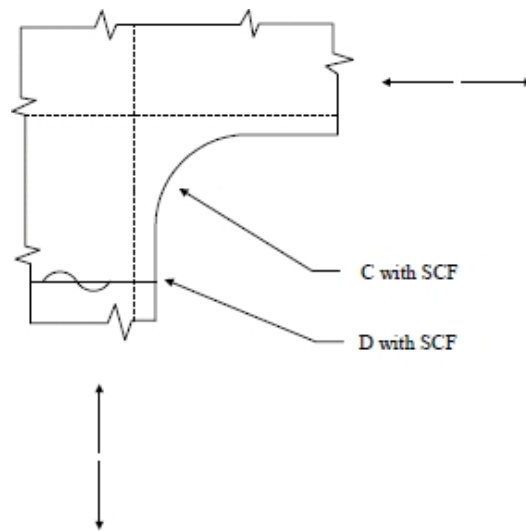

3.3.9 Vertical Supports

Representative vertical supports and seatings fitted to hull and cargo tank structures.

3.3.10 Anti-Roll Chocks

Representative anti-roll chocks and seatings fitted to hull and cargo tank structures.

3.3.11 Anti-Pitch Chocks

Representative anti-pitch chocks and seatings fitted to hull and cargo tank structures.

3.3.12 Bracket Toes of Main Supporting Members of Cargo Tank Structures

Bracket toes of transverse web frames, swash bulkheads and horizontal stringers.

3.3.13 Other Regions and Locations

Other regions and locations (e.g., see 3-A1/3.3.13 FIGURE 4 below), highly stressed by fluctuating loads, as identified from structural analysis.

**FIGURE 4
 Doublers and Non-load Carrying Members on Deck or Shell Plating**

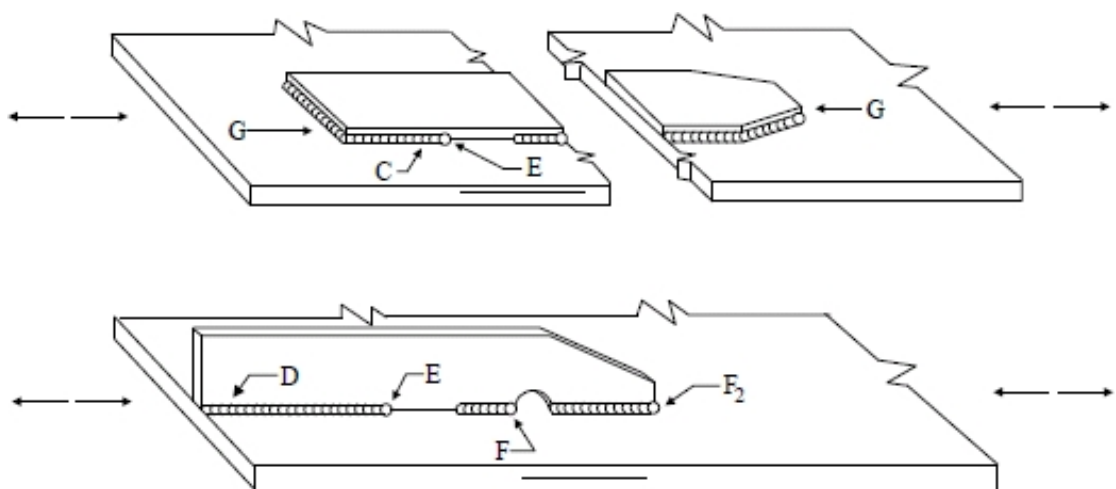
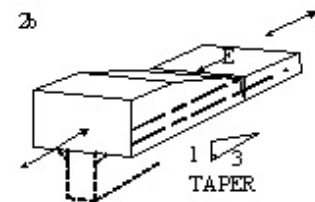
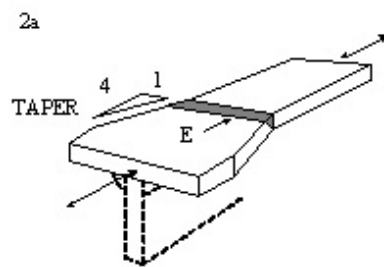

TABLE 1
Fatigue Classification for Structural Details

<i>Class Designation</i>	<i>Description</i>
B	Parent materials, plates or shapes as-rolled or drawn, with no flame-cut edges
C	1) Parent material with automatic flame-cut edges
	2) Full penetration seam welds or longitudinal fillet welds made by an automatic submerged or open arc process, and with no stop-start positions within the length
D	1) Full penetration butt welds between plates of equal width and thickness made either manually or by an automatic process other than submerged arc, from both sides, in downhand position
	2) Welds in C-2) with stop-start positions within the length
E	1) Full penetration butt welds made by other processes than those specified under D-1)
	2) Full penetration butt welds made from both sides between plates of unequal widths machined to a smooth transition with a slope not more than 1 in 4. Plates of different thickness are to be likewise machined with a slope not more than 1 in 3, unless a transition within the weld bead is approved.



3) Welds of brackets and stiffeners to web plate of girders



F 1) Full penetration butt welds made on a permanent backing strip between plates of equal width/thickness or between plates of unequal width/thickness, as specified in E-2.
 2) Rounded fillet welds as shown below

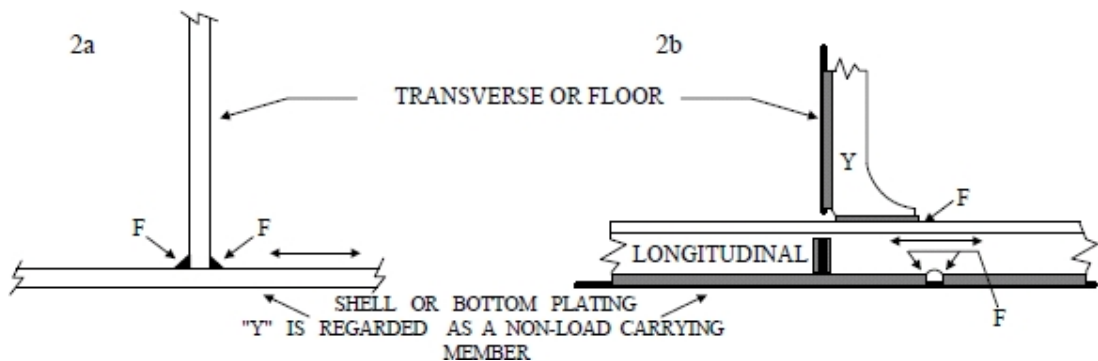

<i>Class Designation</i>	<i>Description</i>
--------------------------	--------------------

- 3) Welds of brackets and stiffeners to flanges

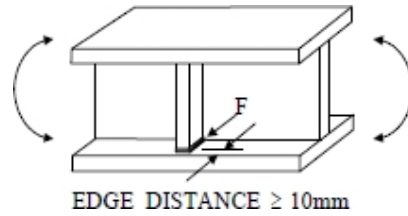

- 4) Attachments on plate or face plate

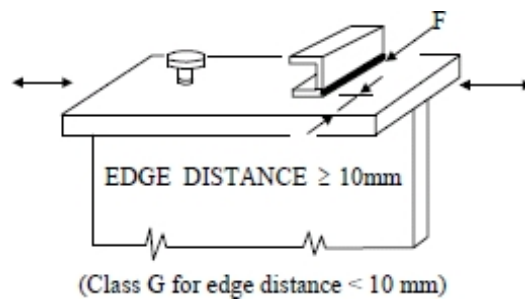

- F2** 1) Fillet welds as shown below with rounded welds and no undercutting

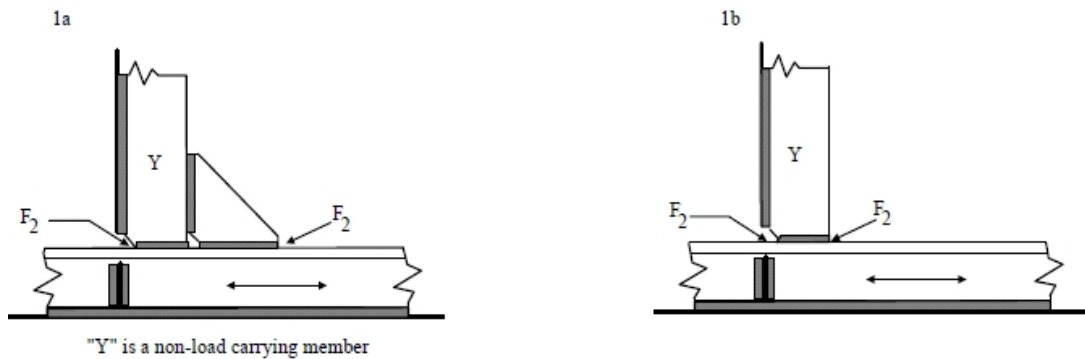

- 2) Fillet welds with any undercutting at the corners dressed out by local grinding

Class Designation

Description

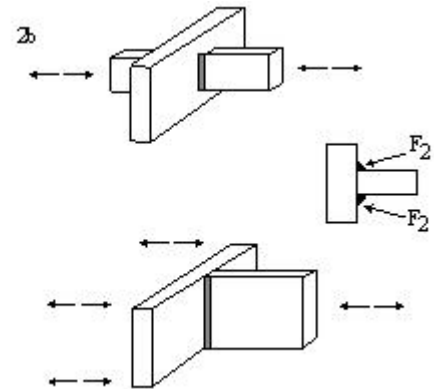
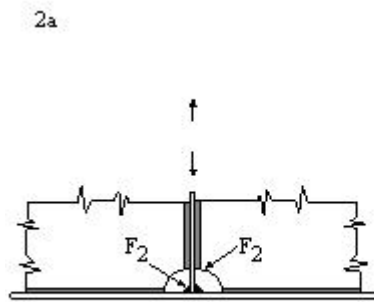

- G**
- 1) Fillet welds in F2 - 1) without rounded toe welds or with limited minor undercutting at corners or bracket toes
 - 2) Overlapped joints
 - 3) Fillet welds in F2 - 3) with minor undercutting
 - 4) Doubler on face plate or flange

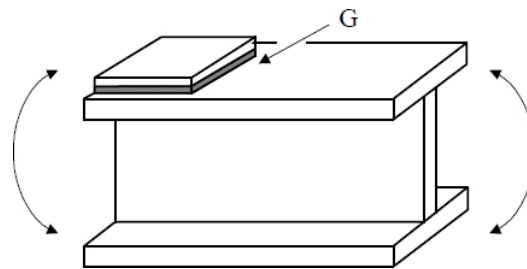

W

Fillet welds-weld throat

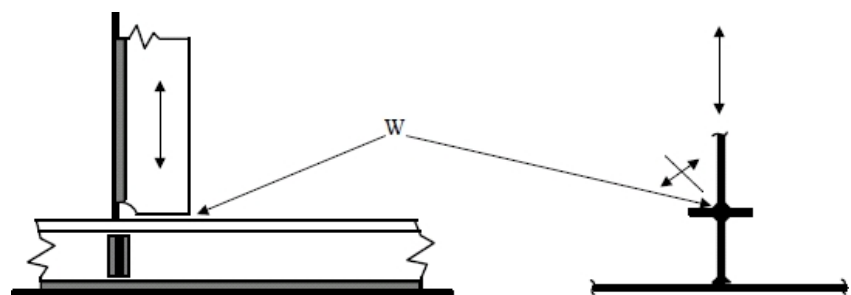

Notes:

- 1 For brackets connecting two or more load carrying members, an appropriate stress concentration factor (SCF) determined from fine mesh 3D or 2D finite element analysis is to be used. In this connection, the fatigue class at bracket toes may be upgraded to class E as shown below.

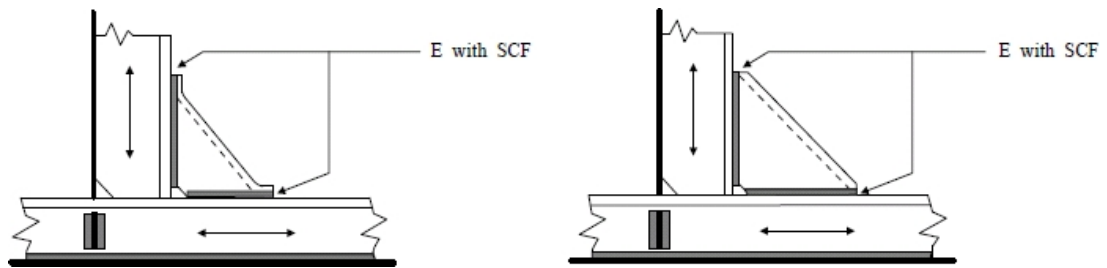

- 2 Additional information on stress concentration factors and the selection of compatible S-N data is given in 3-A1/11.

5 Fatigue Strength Assessment

5.1 Assumptions

The fatigue strength of a structural detail under the loads specified here, in terms of fatigue damage, is to be evaluated using the criteria contained in this section. The key assumptions employed are listed below for guidance.

- A linear cumulative damage model (i.e., Palmgren-Miner’s Rule) has been used in connection with the S-N data in 3-A1/5.7 FIGURE 5 (extracted from Ref. 1*).
- * Ref 1: “Offshore Installations: Guidance on Design, Construction and Certification”, Department of Energy, U.K., Fourth Edition—1990, London: HMSO
- Cyclic stresses due to the loads in 3-A1/7 have been used and the effects of mean stress have been ignored.
- The target life of the floating terminal is taken at 20 years.
- The long-term stress ranges on a detail can be characterized using a modified long term stress distribution parameter (γ).
- Structural details are classified and described in 3-A1/3.3.13 TABLE 1, “Fatigue Classification of Structural Details”.
- Simple nominal stress (e.g., determined by P/A and M/SM) is the basis of fatigue assessment, rather than more localized peak stress in way of weld.

The structural detail classification in 3-A1/3.3.13 TABLE 1 is based on joint geometry and direction of the dominant load. Where the loading or geometry is too complex for a simple classification, a finite element analysis of the details is to be carried out to determine stress concentration factors. 3-A1/13 contains guidance on finite element analysis modeling to determine stress concentration factors for weld toe locations that are typically found at longitudinal stiffener end connections.

5.3 Criteria

The criteria are presented as a comparison of fatigue strength of the structure (capacity), and fatigue inducing loads (demands), in the form of a fatigue damage parameter, DM . The calculated fatigue damage, DM , is to be less than or equal to 1 for the design life of the floating terminal, which corresponds to a fatigue life of 20 years.

5.5 Long Term Stress Distribution Parameter, γ

The long-term distribution parameter, γ , is defined below.

γ	=	$1.40 - 0.2\alpha L^{0.2}$	for	$150 < L < 305$ m
	=	$1.40 - 0.16\alpha L^{0.2}$	for	$492 < L < 1000$ ft
γ	=	$1.54 - 0.245\alpha^{0.8}L^{0.2}$	for	$L > 305$ m
	=	$1.54 - 0.19\alpha^{0.8}L^{0.2}$	for	$L > 1000$ ft

where

- α = 1.0 for deck structures, including side shell and longitudinal bulkhead structures above 0.1D downward from the upper deck at side
- = 0.93 for bottom structures, including inner bottom, and side shell and longitudinal bulkhead structures within 0.1D from the bottom
- = 0.86 for side shell and longitudinal bulkhead structures within the region of 0.25D upward and 0.3D downward from the mid-depth
- = 0.80 for transverse bulkhead structures

α may be linearly interpolated for side shell and longitudinal bulkhead structures between 0.1D and 0.25D (0.2D) from the upper deck (bottom).

L and D are the floating terminal's scantling length and molded depth, as defined in 3-1-1/3.1 and 3-1-1/7.1 of the *Marine Vessel Rules*.

5.7 Cumulative Fatigue Damage

Unless otherwise specified, the resultant cumulative damage is to be taken as:

$$DM = 0.15DM_1 + 0.35DM_2 + 0.35DM_3 + 0.15DM_4$$

where

- DM_i = cumulative fatigue damage ratio for the applicable loading condition i , where $i = 1$ to 4, as specified in 3-A1/7.5.2 FIGURE 6, including 8 loading cases, as shown in 3-A1/Tables 2A through 2D
- = $f_{i,1-2}DM_{i,1-2} + f_{i,3-4}DM_{i,3-4} + f_{i,5-6}DM_{i,5-6} + f_{i,7-8}DM_{i,7-8}$

$f_{i,j-k}$ Factors ⁽¹⁾

	Loading Pair, j-k	1-2	3-4	5-6	7-8
	Direction	0	90	60	30
A ^(2,3,4)	$f_{i,j-k}$, Spread-moored	0.40	0.10	0.20	0.30
B ⁽²⁾	$f_{i,j-k}$, Turret-moored	0.60	0.00	0.10	0.30

Notes:

- 1 If actual heading information is available and submitted, the actual heading probability can be used in lieu of those in the above table.
- 2 In early stages of plan review, or if the conditions are not determined prior to the application of the *Marine Vessel Rules*, both Case A and B are to be investigated and the more onerous results used.
- 3 Also to be used for terminals with turrets located more than 25% of the terminal's length aft of the bow
- 4 Also to be used for locations

Assuming the long term stress ranges fit a two-parameter long term stress distribution, the cumulative fatigue damage DM_i for each relevant condition is to be taken as:

$$DM_{ij-k} = \frac{N_L}{K_2} \frac{(0.01f_{Ri})^m}{(1nN_R)^{m/\gamma}} \mu_i \Gamma\left(1 + \frac{m}{\gamma}\right)$$

where

- N_L = number of cycles for the expected design life. Unless stated otherwise, N_L to be taken as:
 = $\frac{U}{4\log_{10}L}$
 = The value is generally between 0.6×10^8 and 0.8×10^8 cycles for a design life of 20 years
- U = design life, in seconds
 = 6.31×10^8 for a design life of 20 years
- L = rule length, in m
- m = S-N curve parameter as defined in 3-A1/5.7 FIGURE 5, Note a)
- K_2 = S-N curve parameter as defined in 3-A1/5.7 FIGURE 5, Note a)
- f_{Ri} = stress range at the representative probability level of 10^{-4} , in N/cm^2
- N_R = 10 000, number of cycles corresponding to the probability level of 10^{-4}
- γ = long term stress distribution parameter, as defined in 3-A1/5.5
- Γ = Gamma function
- μ_i = stress coefficient taking into account the change in slope of the S-N curve
 = $1 - \frac{\left\{ \Gamma_0\left(1 + \frac{m}{\gamma}, v_i\right) - v_i \frac{\Delta m}{\gamma} \Gamma_0\left(1 + \frac{m + \Delta m}{\gamma}, v_i\right) \right\}}{\Gamma\left(1 + \frac{m}{\gamma}\right)}$
- v_i = $\left(\frac{f_q}{0.01f_{Ri}}\right)^\gamma 1nN_R$
- f_q = stress range at the intersection of the two segments of the S-N curve, see Table in 3-A1/5.7 FIGURE 5, Note a), in N/mm^2
- Δm = slope change of the upper-lower segment of the S-N curve
 = 2
- $\Gamma_0(a, x)$ = incomplete Gamma function, Legendre form

FIGURE 5
Basic Design S-N Curves

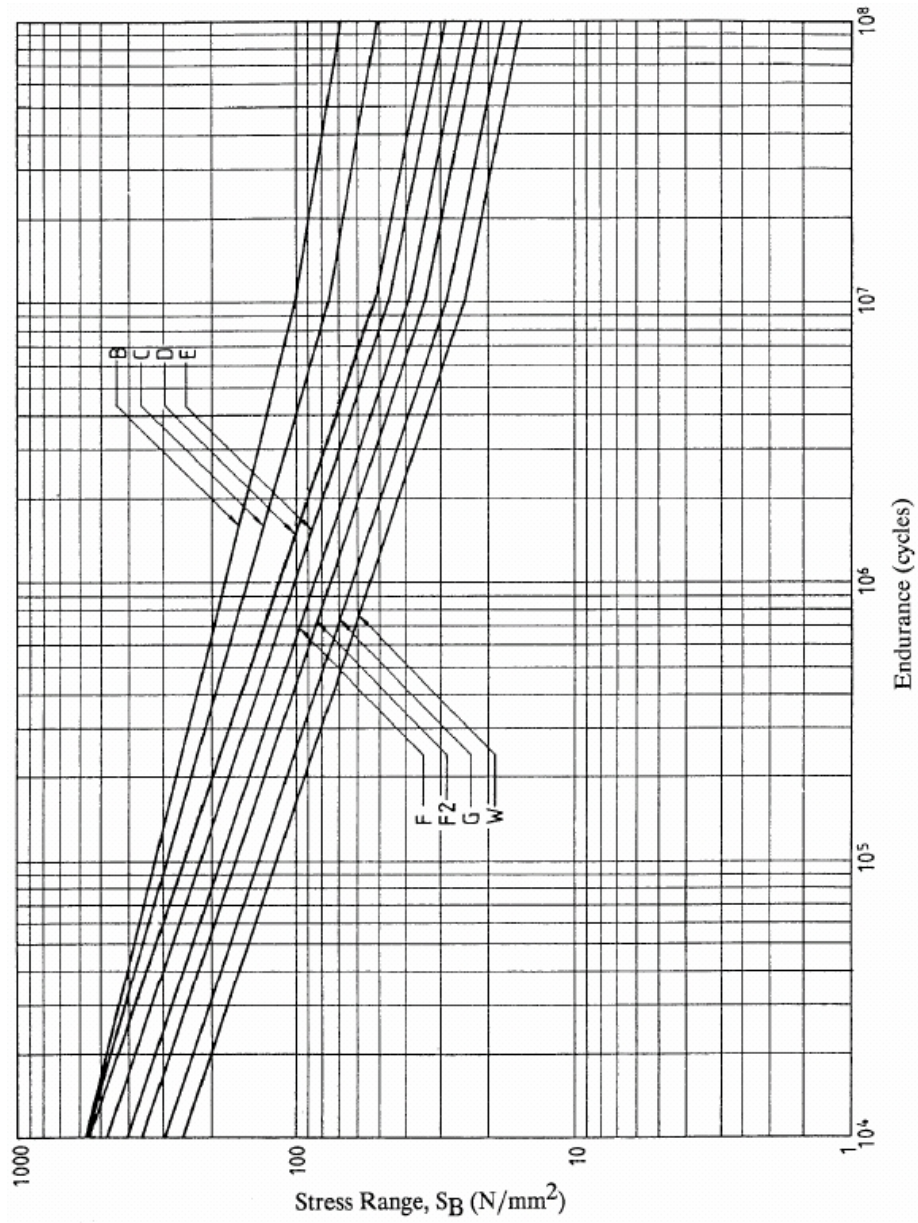

Notes (For 3-A1/Figure 5)

a) Basic design S-N curves

The basic design curves consist of linear relationships between $\log(S_B)$ and $\log(N)$. They are based upon a statistical analysis of appropriate experimental data and may be taken to represent two standard deviations below the mean line.

Thus the basic S-N curves are of the form:

$$\log(N) = \log(K_2) - m\log(S_B)$$

where

$$\log(K_2) = \log(K_1) - 2\sigma$$

N is the predicted number of cycles to failure under stress range S_B ;

K_1 is a constant relating to the mean S-N curve;

σ is the standard deviation of $\log N$;

m is the inverse slope of the S-N curve.

The relevant values of these terms are shown in the table below.

The S-N curves have a change of inverse slope from m to $m + 2$ at $N = 10^7$ cycles.

Details of basic S-N curves

Class	K_1	K_1		m	Standard Deviation		K_2
		\log_{10}	\log_e		\log_{10}	\log_e	
B	2.343×10^{15}	15.3697	35.3900	4.0	0.1821	0.4194	1.01×10^{15}
C	1.082×10^{14}	14.0342	32.3153	3.5	0.2041	0.4700	4.23×10^{13}
D	3.988×10^{12}	12.6007	29.0144	3.0	0.2095	0.4824	1.52×10^{12}
E	3.289×10^{12}	12.5169	28.8216	3.0	0.2509	0.5777	1.04×10^{12}
F	1.726×10^{12}	12.2370	28.1770	3.0	0.2183	0.5027	0.63×10^{12}
F₂	1.231×10^{12}	12.0900	27.8387	3.0	0.2279	0.5248	0.43×10^{12}
G	0.566×10^{12}	11.7525	27.0614	3.0	0.1793	0.4129	0.25×10^{12}
W	0.368×10^{12}	11.5662	26.6324	3.0	0.1846	0.4251	0.16×10^{12}

7 Fatigue Inducing Loads and Determination of Total Stress Ranges

7.1 General

This section provides: 1) the criteria to define the individual load components considered to cause fatigue damage (see 3-A1/7.3); 2) the load combination cases to be considered for different regions of the hull containing the structural detail being evaluated (see 3-A1/7.5); and 3) procedures to idealize the structural components to obtain the total stress range acting on the structure.

7.3 Wave-induced Loads - Load Components

The fatigue-inducing load components to be considered are those induced by the seaway. They are divided into the following three groups:

- Hull girder wave-induced bending moments (both vertical and horizontal), see 3-3/5.1 of this Guide and 3-2-1/3.5 of the *Marine Vessel Rules*
- External hydrodynamic pressures, and
- Internal tank loads (inertial liquid loads and added static head due to vessel motion).

7.5 Fatigue Assessment - Loading Conditions

Four (4) loading conditions are considered in the calculation of stress range, as shown in 3-A1/7.5.2 FIGURE 6. For each loading condition, eight (8) load cases, as shown in 3-A1/Tables 2A through 2D, are defined to form four (4) pairs. The combinations of load cases are to be used to find the characteristic stress range corresponding to a probability of exceedance of 10^{-4} , as indicated below.

7.5.1 Standard Load Combination Cases

7.5.1(a) Calculate dynamic component of stresses for load cases FLC1 through FLC8, respectively, for each of the four loading conditions shown in 3-A1/7.5.2 FIGURE 6.

7.5.1(b) Calculate four sets of stress ranges, one each for the following four pairs of combined loading cases: FLC1 and FLC2, FLC3 and FLC4, FLC5 and FLC6, and FLC7 and FLC8, for each of the four loading conditions shown in 3-A1/7.5.2 FIGURE 6.

7.5.2 Floating Terminals with Either Special Loading Patterns or Special Structural Configuration

For floating terminals with either special loading patterns or special structural configurations/features, additional load cases may be required for determining the stress range.

FIGURE 6
Loading Conditions for Fatigue Strength Assessment

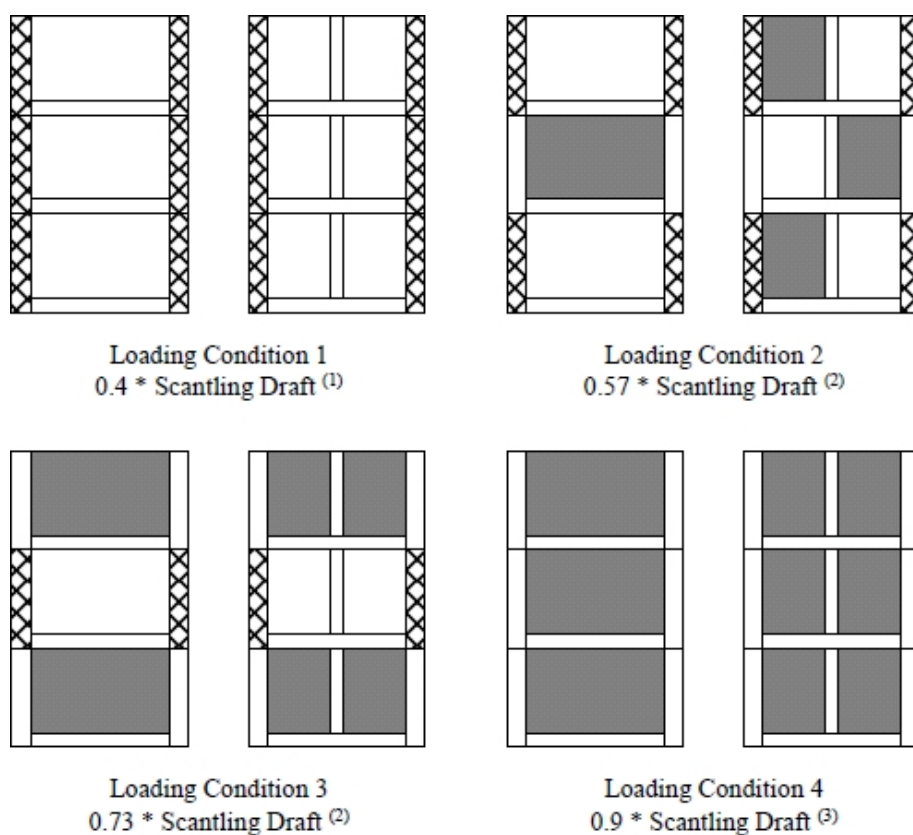

Notes:

- 1 Ballast condition draft - if actual minimum on-site operating ballast draft is greater than $0.4 \times$ scantling draft, actual draft can be used (but not to exceed $0.6 \times$ scantling draft)
This condition is also used for transit condition with actual transit draft between $0.1 \times$ scantling draft and $0.6 \times$ scantling draft
- 2 Intermediate drafts - draft equally divided between Loading Conditions 1 and 4 drafts
- 3 Full load condition draft - if actual maximum on-site operating full load draft is greater than $0.9 \times$ scantling draft, actual draft can be used

TABLE 2A
Design Fatigue Load Cases for Fatigue Strength Assessment

(Load Combination Factors for Dynamic Load Components for Loading Condition 1)

	<i>FLC1</i>	<i>FLC2</i>	<i>FLC3</i>	<i>FLC4</i>	<i>FLC5</i>	<i>FLC6</i>	<i>FLC7</i>	<i>FLC8</i>
A. Hull Girder Loads								
Vertical B.M.	Sag (-)	Hog (+)	Sag (-)	Hog (+)	Sag (-)	Hog (+)	Sag (-)	Hog (+)
k_c	1.00	1.00	0.30	0.30	0.75	0.75	0.70	0.70
Vertical S.F.	(+)	(-)	(+)	(-)	(+)	(-)	(+)	(-)
k_c	0.60	0.60	0.30	0.30	0.55	0.55	0.10	0.10
Horizontal B.M.					(-)	(+)	(-)	(+)
k_c	0.00	0.00	0.10	0.10	1.00	1.00	1.00	1.00
Horizontal S.F.					(+)	(-)	(+)	(-)
k_c	0.00	0.00	0.10	0.10	0.85	0.85	0.85	0.85
B. External Pressure								
k_c	0.80	0.80	1.00	1.00	0.70	0.70	0.45	0.45
k_{f0}	-1.00	1.00	-1.00	1.00	-1.00	1.00	-1.00	1.00
C. Internal Tank Pressure								
k_c	0.40	0.40	1.00	1.00	0.75	0.75	0.40	0.40
w_v	0.40	-0.40	0.75	-0.75	0.10	-0.10	0.25	-0.25
w_ℓ	Fwd Bhd 0.20	Fwd Bhd -0.20	—	—	Fwd Bhd 0.50	Fwd Bhd -0.50	Fwd Bhd 0.80	Fwd Bhd -0.80
	Aft Bhd -0.20	Aft Bhd 0.20	—	—	Aft Bhd -0.50	Aft Bhd 0.50	Aft Bhd -0.80	Aft Bhd 0.80
w_t	—	—	Port Bhd -0.85	Port Bhd 0.85	Port Bhd -0.05	Port Bhd 0.05	Port Bhd -0.05	Port Bhd 0.05
	—	—	Stbd Bhd 0.85	Stbd Bhd -0.85	Stbd Bhd 0.05	Stbd Bhd -0.05	Stbd Bhd 0.05	Stbd Bhd -0.05
c_ϕ , Pitch	-0.15	0.15	-0.10	0.10	-0.30	0.30	-0.45	0.45
c_θ , Roll	0.00	0.00	1.00	-1.00	0.05	-0.05	0.05	-0.05

	<i>FLC1</i>	<i>FLC2</i>	<i>FLC3</i>	<i>FLC4</i>	<i>FLC5</i>	<i>FLC6</i>	<i>FLC7</i>	<i>FLC8</i>
D. Reference Wave Heading and Motion of Installation								
Heading Angle	0	0	90	90	60	60	30	30
Heave	Down	Up	Down	Up	Down	Up	Down	Up
Pitch	Bow Down	Bow Up	Bow Down	Bow Up	Bow Down	Bow Up	Bow Down	Bow Up
Roll	—	—	Stbd Down	Stbd Up	Stbd Down	Stbd Up	Stbd Down	Stbd Up

Notes:

- 1 Rule vertical bending moment range = $|M_{ws} - M_{wh}|$ (see 3-3/5.1.1 for M_{ws} and M_{wh})
- 2 Rule horizontal bending moment range = $2 \times M_h$ (see 3-3/5.3.1 for M_h)
- 3 For each load condition pair, the stress range due to local pressure is the difference between the stress values for Local Pressure Load Conditions. For example, for Load Condition Pair *FLC1* & *FLC2*, the stress range due to local pressure is the difference between the stress values for *FLC1* and *FLC2*.
- 4 For each load condition pair, the stress range is the sum of the absolute stress range values due to Vertical BM, Horizontal BM and Local Pressure Load Conditions.

TABLE 2B
Design Fatigue Load Cases for Fatigue Strength Assessment

(Load Combination Factors for Dynamic Load Components for Loading Condition 2)

	<i>FLC1</i>	<i>FLC2</i>	<i>FLC3</i>	<i>FLC4</i>	<i>FLC5</i>	<i>FLC6</i>	<i>FLC7</i>	<i>FLC8</i>
A. Hull Girder Loads								
Vertical B.M.	Sag (-)	Hog (+)	Sag (-)	Hog (+)	Sag (-)	Hog (+)	Sag (-)	Hog (+)
k_c	1.00	1.00	0.25	0.25	0.95	0.95	0.75	0.75
Vertical S.F.	(+)	(-)	(+)	(-)	(+)	(-)	(+)	(-)
k_c	0.55	0.55	0.15	0.15	0.70	0.70	0.25	0.25
Horizontal B.M.					(-)	(+)	(-)	(+)
k_c	0.00	0.00	0.10	0.10	1.00	1.00	1.00	1.00
Horizontal S.F.					(+)	(-)	(+)	(-)
k_c	0.00	0.00	0.15	0.15	0.80	0.80	0.80	0.80
B. External Pressure								
k_c	0.85	0.85	0.90	0.90	0.90	0.90	0.55	0.55
k_{f0}	-1.00	1.00	-1.00	1.00	-1.00	1.00	-1.00	1.00
C. Internal Tank Pressure								
k_c	0.55	0.55	0.70	0.70	0.20	0.20	0.40	0.40
w_v	0.60	-0.60	0.55	-0.55	0.15	-0.15	0.25	-0.25

	<i>FLC1</i>	<i>FLC2</i>	<i>FLC3</i>	<i>FLC4</i>	<i>FLC5</i>	<i>FLC6</i>	<i>FLC7</i>	<i>FLC8</i>
w_ℓ	Fwd Bhd 0.20	Fwd Bhd -0.20	—	—	Fwd Bhd 0.45	Fwd Bhd -0.45	Fwd Bhd 0.75	Fwd Bhd -0.75
	Aft Bhd -0.20	Aft Bhd 0.20	—	—	Aft Bhd -0.45	Aft Bhd 0.45	Aft Bhd -0.75	Aft Bhd 0.75
w_t	—	—	Port Bhd -0.95	Port Bhd 0.95	Port Bhd -0.05	Port Bhd 0.05	Port Bhd -0.10	Port Bhd 0.10
	—	—	Stbd Bhd 0.95	Stbd Bhd -0.95	Stbd Bhd 0.05	Stbd Bhd -0.05	Stbd Bhd 0.10	Stbd Bhd -0.10
c_ϕ , Pitch	-0.20	0.20	-0.05	0.05	-0.10	0.10	-0.35	0.35
c_θ , Roll	0.00	0.00	1.00	-1.00	0.05	-0.05	0.05	-0.05
D. Reference Wave Heading and Motion of Installation								
Heading Angle	0	0	90	90	60	60	30	30
Heave	Down	Up	Down	Up	Down	Up	Down	Up
Pitch	Bow Down	Bow Up	Bow Down	Bow Up	Bow Down	Bow Up	Bow Down	Bow Up
Roll	—	—	Stbd Down	Stbd Up	Stbd Down	Stbd Up	Stbd Down	Stbd Up

Notes:

- 1 Rule vertical bending moment range = $|M_{ws} - M_{wh}|$ (see 3-3/5.1.1 for M_{ws} and M_{wh})
- 2 Rule horizontal bending moment range = $2 \times M_h$ (see 3-3/5.3.1 for M_h)
- 3 For each load condition pair, the stress range due to local pressure is the difference between the stress values for Local Pressure Load Conditions. For example, for Load Condition Pair *FLC1* & *FLC2*, the stress range due to local pressure is the difference between the stress values for *FLC1* and *FLC2*.
- 4 For each load condition pair, the stress range is the sum of the absolute stress range values due to Vertical BM, Horizontal BM and Local Pressure Load Conditions.

TABLE 2C
Design Fatigue Load Cases for Fatigue Strength Assessment

(Load Combination Factors for Dynamic Load Components for Loading Condition 3)

	<i>FLC1</i>	<i>FLC2</i>	<i>FLC3</i>	<i>FLC4</i>	<i>FLC5</i>	<i>FLC6</i>	<i>FLC7</i>	<i>FLC8</i>
A. Hull Girder Loads								
Vertical B.M.	Sag (-)	Hog (+)	Sag (-)	Hog (+)	Sag (-)	Hog (-)	Sag (-)	Hog (+)
k_c	1.00	1.00	0.25	0.25	0.90	0.90	0.70	0.70
Vertical S.F.	(+)	(-)	(+)	(-)	(+)	(-)	(+)	(-)
k_c	0.55	0.55	0.10	0.10	0.65	0.65	0.30	0.30
Horizontal B.M.					(-)	(+)	(-)	(+)
k_c	0.00	0.00	0.10	0.10	1.00	1.00	1.00	1.00
Horizontal S.F.					(+)	(-)	(+)	(-)

	<i>FLC1</i>	<i>FLC2</i>	<i>FLC3</i>	<i>FLC4</i>	<i>FLC5</i>	<i>FLC6</i>	<i>FLC7</i>	<i>FLC8</i>
k_c	0.00	0.00	0.30	0.30	0.85	0.85	0.80	0.80
B. External Pressure								
k_c	0.85	0.85	0.85	0.85	0.85	0.85	0.75	0.75
k_{f0}	-1.00	1.00	-1.00	1.00	-1.00	1.00	-1.00	1.00
C. Internal Tank Pressure								
k_c	0.55	0.55	0.75	0.75	0.10	0.10	0.40	0.40
w_v	0.55	-0.55	0.55	-0.55	0.15	-0.15	0.30	-0.30
w_ℓ	Fwd Bhd 0.20	Fwd Bhd -0.20	—	—	Fwd Bhd 0.40	Fwd Bhd -0.40	Fwd Bhd 0.80	Fwd Bhd -0.80
	Aft Bhd -0.20	Aft Bhd 0.20	—	—	Aft Bhd -0.40	Aft Bhd 0.40	Aft Bhd -0.80	Aft Bhd 0.80
w_t	—	—	Port Bhd -1.00	Port Bhd 1.00	Port Bhd -0.05	Port Bhd 0.05	Port Bhd -0.15	Port Bhd 0.15
	—	—	Stbd Bhd 1.00	Stbd Bhd -1.00	Stbd Bhd 0.05	Stbd Bhd -0.05	Stbd Bhd 0.15	Stbd Bhd -0.15
c_ϕ , Pitch	-0.15	0.15	-0.15	0.15	-0.20	0.20	-0.45	0.45
c_θ , Roll	0.00	0.00	1.00	-1.00	0.05	-0.05	0.10	-0.10
D. Reference Wave Heading and Motion of Installation								
Heading Angle	0	0	90	90	60	60	30	30
Heave	Down	Up	Down	Up	Down	Up	Down	Up
Pitch	Bow Down	Bow Up	Bow Down	Bow Up	Bow Down	Bow Up	Bow Down	Bow Up
Roll	—	—	Stbd Down	Stbd Up	Stbd Down	Stbd Up	Stbd Down	Stbd Up

Notes:

- 1 Rule vertical bending moment range = $|M_{ws} - M_{wh}|$ (see 3-3/5.1.1 for M_{ws} and M_{wh})
- 2 Rule horizontal bending moment range = $2 \times M_h$ (see 3-3/5.3.1 for M_h)
- 3 For each load condition pair, the stress range due to local pressure is the difference between the stress values for Local Pressure Load Conditions. For example, for Load Condition Pair *FLC1* & *FLC2*, the stress range due to local pressure is the difference between the stress values for *FLC1* and *FLC2*.
- 4 For each load condition pair, the stress range is the sum of the absolute stress range values due to Vertical BM, Horizontal BM and Local Pressure Load Conditions.

TABLE 2D
Design Fatigue Load Cases for Fatigue Strength Assessment

(Load Combination Factors for Dynamic Load Components for Loading Condition 4)

	<i>FLC1</i>	<i>FLC2</i>	<i>FLC3</i>	<i>FLC4</i>	<i>FLC5</i>	<i>FLC6</i>	<i>FLC7</i>	<i>FLC8</i>
A. Hull Girder Loads								
Vertical B.M.	Sag (-)	Hog (+)	Sag (-)	Hog (+)	Sag (-)	Hog (+)	Sag (-)	Hog (+)
k_c	1.00	1.00	0.15	0.15	0.80	0.80	0.70	0.70
Vertical S.F.	(+)	(-)	(+)	(-)	(+)	(-)	(+)	(-)
k_c	0.55	0.55	0.20	0.20	0.50	0.50	0.40	0.40
Horizontal B.M.					(-)	(+)	(-)	(+)
k_c	0.00	0.00	0.25	0.25	1.00	1.00	1.00	1.00
Horizontal S.F.					(+)	(-)	(+)	(-)
k_c	0.00	0.00	0.25	0.25	0.85	0.85	0.80	0.80
B. External Pressure								
k_c	0.85	0.85	0.90	0.90	0.80	0.80	0.95	0.95
k_{f0}	-1.00	1.00	-1.00	1.00	-1.00	1.00	-1.00	1.00
C. Internal Tank Pressure								
k_c	0.75	0.75	0.80	0.80	0.10	0.10	0.50	0.50
w_v	0.85	-0.85	0.60	-0.60	0.10	-0.10	0.30	-0.30
w_ℓ	Fwd Bhd 0.20	Fwd Bhd -0.20	—	—	Fwd Bhd 0.30	Fwd Bhd -0.30	Fwd Bhd 1.00	Fwd Bhd -1.00
	Aft Bhd -0.20	Aft Bhd 0.20	—	—	Aft Bhd -0.30	Aft Bhd 0.30	Aft Bhd -1.00	Aft Bhd 1.00
w_t	—	—	Port Bhd -1.00	Port Bhd 1.00	Port Bhd -0.05	Port Bhd 0.05	Port Bhd -0.10	Port Bhd 0.10
	—	—	Stbd Bhd 1.00	Stbd Bhd -1.00	Stbd Bhd 0.05	Stbd Bhd -0.05	Stbd Bhd 0.10	Stbd Bhd -0.10
c_ϕ , Pitch	-0.30	0.30	-0.15	0.15	-0.10	0.10	-0.80	0.80
c_θ , Roll	0.00	0.00	1.00	-1.00	0.05	-0.05	0.15	-0.15
D. Reference Wave Heading and Motion of Installation								
Heading Angle	0	0	90	90	60	60	30	30
Heave	Down	Up	Down	Up	Down	Up	Down	Up
Pitch	Bow Down	Bow Up	Bow Down	Bow Up	Bow Down	Bow Up	Bow Down	Bow Up
Roll	—	—	Stbd Down	Stbd Up	Stbd Down	Stbd Up	Stbd Down	Stbd Up

Notes:

- 1 Rule vertical bending moment range = $|M_{ws} - M_{wh}|$ (see 3-3/5.1.1 for M_{ws} and M_{wh})
- 2 Rule horizontal bending moment range = $2 \times M_h$ (see 3-3/5.3.1 for M_h)

- 3 For each load condition pair, the stress range due to local pressure is the difference between the stress values for Local Pressure Load Conditions. For example, for Load Condition Pair *FLC1* & *FLC2*, the stress range due to local pressure is the difference between the stress values for *FLC1* and *FLC2*.
- 4 For each load condition pair, the stress range is the sum of the absolute stress range values due to Vertical BM, Horizontal BM and Local Pressure Load Conditions.

7.7 Primary Stress f_{d1}

f_{d1v} and f_{d1h} may be calculated by a simple beam approach. For assessing fatigue strength of side shell and longitudinal bulkhead plating at welded connections, the value of wave-induced primary stress is to be taken as that of maximum principal stress at the location considered to account for the combined load effects of the direct stresses and shear stresses. For calculating the value of f_{d1v} for longitudinal deck members, normal camber may be disregarded.

7.9 Secondary Stress f_{d2}

f_{d2} may be obtained from orthotropic plating or grillage methods with appropriate boundary conditions.

For those connections specified in 3-A1/3.3.1, the wave-induced secondary bending stress f_{d2} may be ignored.

7.11 Additional Secondary Stresses f_{d2}^* and Tertiary Stresses f_{d3}

7.11.1 Calculation of f_{d2}^*

Where required, the additional secondary stresses acting at the flange of a longitudinal stiffener, f_{d2}^* , may be approximated by

$$f_{d2}^* = C_t C_y M / SM \quad \text{N/cm}^2 \text{ (kgf/cm}^2, \text{ lbf/in}^2\text{)}$$

where

$$M = C_d p s \ell^2 / 12 \text{ N-cm (kgf-cm, lbf-in), at the supported ends of longitudinal}$$

Where flat bar stiffeners or brackets are fitted, the bending moment, M , given above, may be adjusted to the location of the bracket's toe, (i.e., M_X in 3-4/Figure 4).

Where a longitudinal has remarkably different support stiffness at its two ends (e.g., a longitudinal connected to a transverse bulkhead on one end), considerations should be given to the increase of bending moment at the joint.

- | | | |
|--------|--------|---|
| C_d | = 1.15 | for longitudinal stiffener connections at the transverse bulkhead for |
| | | <ul style="list-style-type: none"> • all longitudinals of single hull tankers, and • deck longitudinals, and longitudinals on longitudinal bulkheads, except for the outermost ones of double hull tanker |
| | = 1.0 | elsewhere |
| p | = | wave-induced local net pressure, in N/cm^2 (kgf/cm^2 , lbf/in^2), for the specified location and load cases at the mid-span of the longitudinal considered |
| s | = | spacing of longitudinal stiffener, in cm (in.) |
| ℓ | = | unsupported span of longitudinal/stiffener, in cm (in.), as shown in 3-4/Figure 3 |
| SM | = | net section modulus of longitudinal with the associated effective plating, in cm^3 (in^3), at flange or point considered. The effective breadth, b_e , in cm (in.), may be determined as shown in 3-4/Figure 4. |

$$C_y = 0.656(d/z)^4 \quad \text{for side shell longitudinals only where } z/d \geq 0.9, \text{ but } C_y \geq 0.30$$

$$= 1.0 \quad \text{elsewhere}$$

z = distance above keel of side shell longitudinal under consideration

d = draft, m (ft), as defined in 3-1-1/9 of the *Marine Vessel Rules*

C_t = correction factor for the combined bending and torsional stress induced by lateral loads at the welded connection of the flat bar stiffener or bracket to the flange of longitudinal, as shown in 3-4/Figure 3.

$$= 1.0 + a_r \quad \text{for unsymmetrical sections, fabricated or rolled}$$

$$= 1.0 \quad \text{for tee and flat bars}$$

$a_r = C_n C_p SM/K$

$$C_p = 31.2 d_w (e/\ell)^2$$

e = horizontal distance between web centerline and shear center of the cross section, including longitudinal and the effective plating

$$\approx d_w b_f^2 t_f u / (2SM) \quad \text{cm(in.)}$$

K = St. Venant torsion constant for the longitudinal's cross section, excluding the associated plating.

$$= [b_f t_f^3 + d_w t_w^3] / 3 \quad \text{cm}^4(\text{in}^4)$$

C_n = coefficient given in 3-A1/7.11.2 FIGURE 7, as a function of Ψ , for point (1) shown in 3-A2/5.3 FIGURE 1.

$$u = 1 - 2b_1/b_f$$

$$\Psi = 0.31\ell (K/\Gamma)^{1/2}$$

Γ = warping constant

$$= m I_{yf} d_w^2 + d_w^3 t_w^3 / 36 \quad \text{cm}^6(\text{in}^6)$$

$$I_{yf} = t_f b_f^3 (1.0 + 3.0 u^2 A_w / A_s) / 12 \quad \text{cm}^4(\text{in}^4)$$

$$A_w = d_w t_w \quad \text{cm}^2(\text{in}^2)$$

$$A_s = \text{net sectional area of the longitudinals excluding the associated plating, cm}^2(\text{in}^2)$$

$$m = 1.0 - u(0.7 - 0.1 d_w / b_f)$$

d_w, t_w, b_1, b_f, t_f , all in cm (in.), are as defined in 3-A2/5.3 FIGURE 1.

For general applications, a_r needs not to be taken greater than 0.65 for a fabricated angle bar and 0.50 for a rolled section.

For connection as specified in 3-A1/3.3.2, the wave-induced additional secondary stress f_{d2}^* may be ignored.

7.11.2 Calculation of f_{d3}

For welded joints of a stiffened plate panel, f_{d3} may be determined based on the wave-induced local loads as specified in 3-A1/7.11.1 above, using the approximate equations given below. For direct calculation, non-linear effect and membrane stresses in the plate may be considered.

For plating subjected to lateral load, f_{d3} in the longitudinal direction is determined as:

$$f_{d3} = 0.182p(s/t_n)^2 \quad \text{N/cm}^2(\text{kgf/cm}^2, \text{lbf/in}^2)$$

where

p = wave-induced local net pressure, in N/cm² (kgf/cm², lbf/in²)

s = spacing of longitudinal stiffeners, in cm (in.)

t_n = net thickness of plate, in mm (in.)

FIGURE 7
 $C_n = C_n(\Psi)$

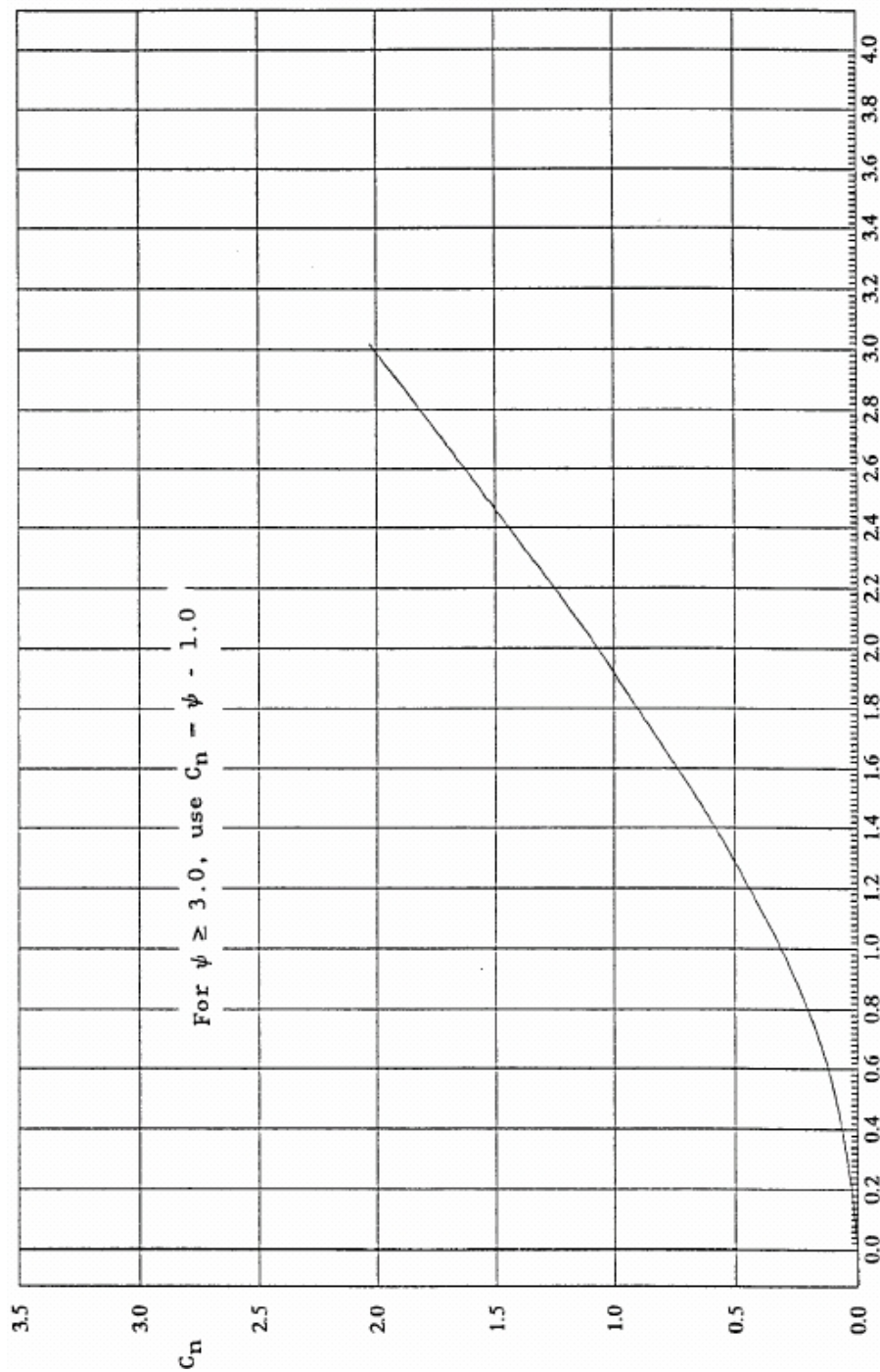

9 Resulting Stress Ranges

9.1 Definitions

9.1.1

The total stress range, f_r , is computed as the sum of the two stress ranges as follows:

$$f_R k_p c_f (f_{RG} + f_{RL}) \quad \text{N/cm}^2 \text{ (kgf/cm}^2, \text{ lbf/in}^2\text{)}$$

where

f_{RG}	=	global dynamic stress range, in N/cm ² (kgf/cm ² , lbf/in ²)
	=	$ (f_{d1vi} - f_{d1vj}) + (f_{d1hi} - f_{d1hj}) $
f_{RL}	=	local dynamic stress range, in N/cm ² (kgf/cm ² , lbf/in ²)
	=	$ (f_{d2i} + f_{d2i}^* + f_{d3i}) - (f_{d2j} + f_{d2j}^* + f_{d3j}) $
k_p	=	load factor for adjusting the probability of exceedance
	=	0.5
c_f	=	adjustment factor to reflect a mean wasted condition
	=	0.95
$f_{d1vi} f_{d1vj}$	=	wave-induced component of the primary stresses produced by hull girder vertical bending, in N/cm ² (kgf/cm ² , lbf/in ²), for load case <i>i</i> and <i>j</i> of the selected pairs of combined load cases, respectively
$f_{d1hi} f_{d1hj}$	=	wave-induced component of the primary stresses produced by hull girder horizontal bending, in N/cm ² (kgf/cm ² , lbf/in ²), for load case <i>i</i> and <i>j</i> of the selected pairs of combined load cases, respectively
$f_{d2i} f_{d2j}$	=	wave-induced component of the secondary bending stresses produced by the bending of cross-stiffened panels between transverse bulkheads, in N/cm ² (kgf/cm ² , lbf/in ²), for load case <i>i</i> and <i>j</i> of the selected pairs of combined load cases, respectively
$f_{d2i}^* f_{d2j}^*$	=	wave-induced component of the additional secondary stresses produced by the local bending of the longitudinal stiffener between supporting structures (e.g., transverse bulkheads and web frames), in N/cm ² (kgf/cm ² , lbf/in ²), for load case <i>i</i> and <i>j</i> of the selected pairs of combined load cases, respectively
$f_{d3i} f_{d3j}$	=	wave-induced component of the tertiary stresses produced by the local bending of plate elements between the longitudinal stiffeners in, N/cm ² (kgf/cm ² , lbf/in ²), for load case <i>i</i> and <i>j</i> of the selected pairs of combined load cases, respectively

For calculating the wave-induced stresses, sign convention is to be observed for the respective directions of wave-induced loads, as specified in 3-A1/Tables 2A through 2D. The wave-induced local loads are to be calculated with the sign convention for the external and internal loads. However, the total of the external and internal pressures, including both static and dynamic components, need not be taken less than zero.

These wave-induced stresses are to be determined based on the net ship scantlings (see 3-A1/1.3) and in accordance with 3-A1/7.5 through 3-A1/7.11. The results of direct calculation where carried out may also be considered.

11 Determination of Stress Concentration Factors (SCF's)

11.1 General

This section contains information on stress concentration factors (SCF's) to be considered in the fatigue assessment.

Where, for a particular example shown, no specific value of SCF is given when one is called for, it indicates that a finite element analysis is needed. When the fine mesh finite element approach is used,

additional information on calculations of stress concentration factors and the selection of compatible S-N data is given in 3-A1/13.

11.3 Sample Stress Concentration Factors (SCF's)

11.3.1 Cut-outs (Slots) for Longitudinals

SCF's, fatigue classifications and peak stress ranges may be determined in accordance with 3-A1/11.3.1 TABLE 3 and 3-A1/11.3.1 FIGURE 8.

TABLE 3
 K_S (SCF) Values

<i>Configuration</i>	K_S (SCF)					
	<i>Unsymmetrical Flange</i>			<i>Symmetrical Flange</i>		
Location	[1]	[2]	[3]	[1]	[2]	[3]
Single-sided Support	2.0	2.1	—	1.8	1.9	—
Single-sided Support with F.B. Stiffener	1.9	2.0	—	1.7	1.8	—
Double-sided Support	3.0	2.6	2.4	2.7	2.4	2.2
Double-sided Support with F.B. Stiffener	2.8	2.5	2.3	2.5	2.3	2.1

Notes: **a** The value of K_S is given based on nominal shear stresses near the locations under consideration.

b Fatigue classification

Locations [1] and [2]: Class C or B as indicated in 3-A1/3.3.13 TABLE 1

Location [3]: Class F

c The peak stress range is to be obtained from the following equations:

1 For locations [1] and [2]

$$f_{Ri} = c_f [K_{Si} f_{si} + f_{ni}]$$

where

$$c_f = 0.95$$

$$f_{si} = f_{sc} + \alpha_i f_{swi} \quad f_{si} \geq f_{sc}$$

$$\alpha_i = 1.8 \text{ for single-sided support}$$

$$= 1.0 \text{ for double-sided support}$$

$$f_{ni} = \text{normal stress range in the web plate}$$

$$f_{swi} = \text{shear stress range in the web plate}$$

$$= F_i / A_w$$

F_i is the calculated web shear force range at the location considered. A_w is the area of web.

$$f_{sc} = \text{shear stress range in the support (lug or collar plate)}$$

$$= C_y P / (A_c + A_s)$$

C_y is as defined in 3-A1/7.11.1.

$$P = s \ell p_o$$

$$p_o = \text{fluctuating lateral pressure}$$

$$A_c = \text{sectional area of the support or of both supports for double-sided support}$$

$$A_s = \text{sectional area of the flat bar stiffener, if any}$$

$$K_{Si} = \text{SCF's given above}$$

$$s = \text{spacing of longitudinal/stiffener}$$

$$\ell = \text{spacing of transverses}$$

2 For location [3]

$$f_{R3} = c_f [f_{n3}^2 + (K_S f_{s2})^2]^{1/2}$$

where

$$c_f = 0.95$$

$$f_{n3} = \text{normal stress range at location [3]}$$

$$f_{s2} = \text{shear stress range as defined in 1 above near location [3].}$$

$$K_S = \text{SCF's given above}$$

FIGURE 8
Cut-outs (Slots) For Longitudinal

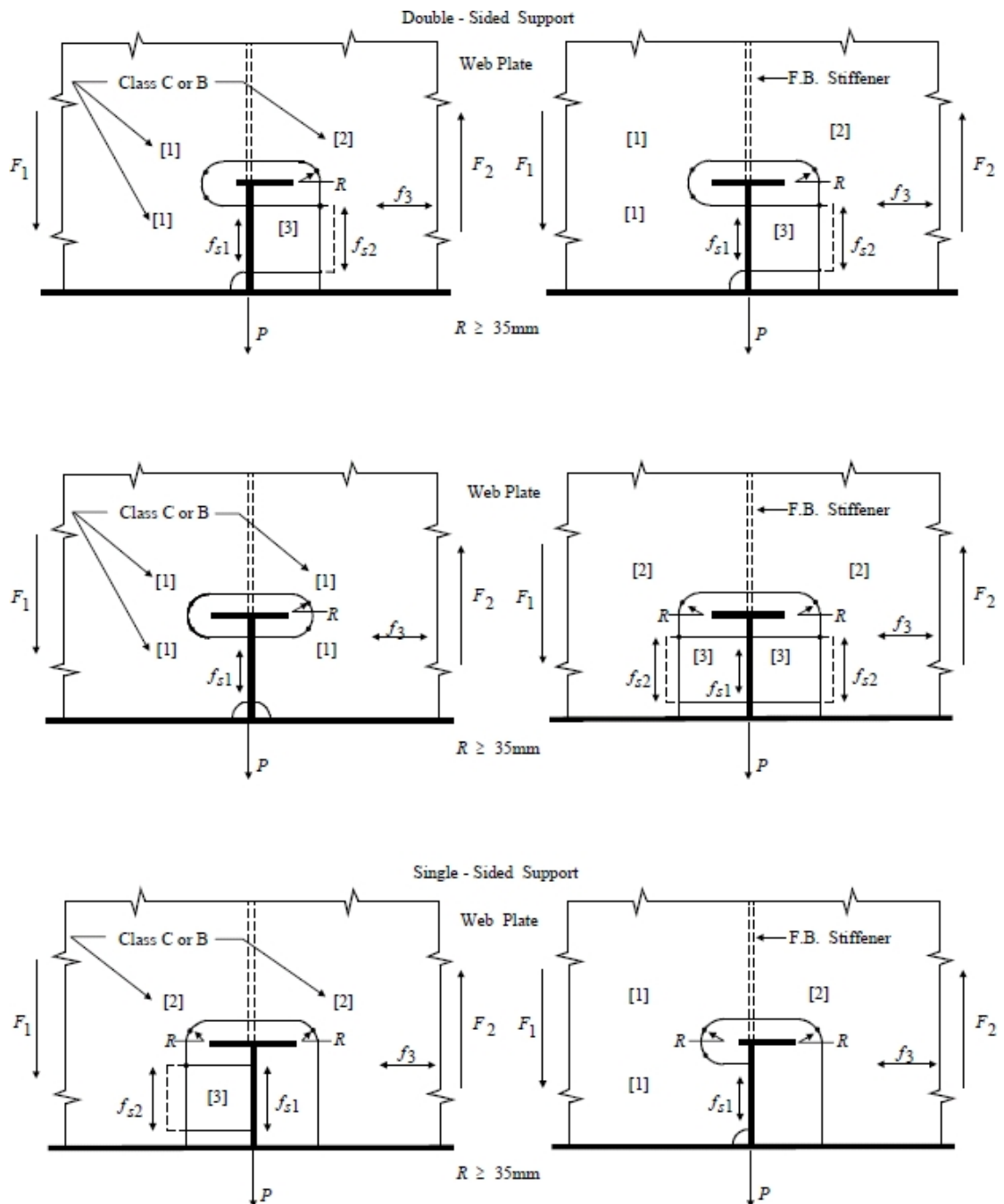

11.3.2 Flat Bar Stiffener for Longitudinals

11.3.2(a)

For assessing fatigue life of the flat bar stiffener at location [1] or [2], the peak stress range is to be obtained from the following equations:

$$f_{Ri} = [(\alpha_i f_s)^2 + f_{Li}^2]^{1/2} \quad (i = 1 \text{ or } 2)$$

where

$$f_s = \text{nominal stress range in the flat bar stiffener.}$$

$$= k_p c_f C_y P / (A_s + A_c)$$

P, A_s, A_c, c_f are as defined in 3-A1/11.3.2 and C_y in 3-A1/7.11.1. For flat bar stiffener with soft-toed brackets, the brackets may be included in the calculation of A_s .

$$k_p = \text{load factor for adjusting the probability of exceedance}$$

$$= 0.5$$

$$f_{Li} = \text{stress range in the longitudinal at Location } i \text{ (} i = 1 \text{ or } 2\text{), as specified in 3-A1/9}$$

$$\alpha_i = \text{stress concentration factor at Location } i \text{ (} i = 1 \text{ or } 2\text{) accounting for misalignment and local distortion}$$

At location [1]

For flat bar stiffener without brackets

$$\alpha_1 = 1.50 \quad \text{for double-sided support connection}$$

$$= 2.00 \quad \text{for single-sided support connection}$$

For flat bar stiffener with brackets

$$\alpha_1 = 1.00 \quad \text{for double-sided support connection}$$

$$= 1.25 \quad \text{for single-sided support connection}$$

At location [2]

For flat bar stiffener without brackets

$$\alpha_2 = 1.25 \quad \text{for single or double-sided support connection}$$

For flat bar stiffener with brackets

$$\alpha_2 = 1.00 \quad \text{for single or double-sided support connection}$$

11.3.2(b)

For assessing the fatigue life of the weld throat as shown in 3-A1/Table 1, Class W, the peak stress range at the weld may be obtained from the following equation:

$$f_R = 1.25 f_s A_s / A_{sw}$$

where

$$A_{sw} = \text{sectional area of the weld throat. Brackets may be included in the calculation of } A_{sw}.$$

f_s and A_s are as defined in 3-A1/11.3.2(a) above.

11.3.2(c)

For assessing fatigue life of the longitudinal, the fatigue classification given in 3-A1/Table 1 for a longitudinal as the only load-carrying member is to be considered. Alternatively, the fatigue classification shown in 3-A1/Figure 9, in conjunction with the combined stress effects, may be used. In calculation of f_s , the α_i may be taken as 1.25 for both locations [1] and [2].

FIGURE 9
Fatigue Classification for Longitudinals in way of Flat Bar Stiffener

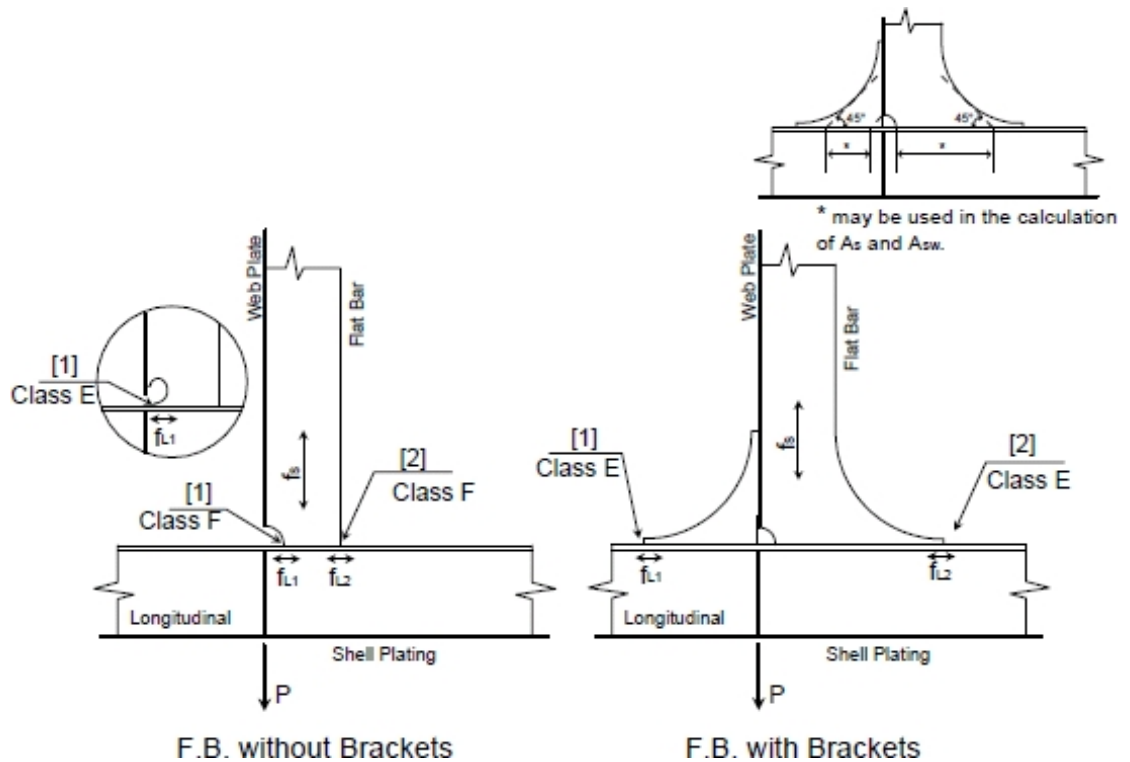

11.3.3 Connections Between Sloping Bulkhead and Inner Bottom, Longitudinal Bulkhead and Inner Deck

Fatigue class designation and SCF's may be determined as shown in 3-A1/11.3.3 FIGURE 10 below.

FIGURE 10

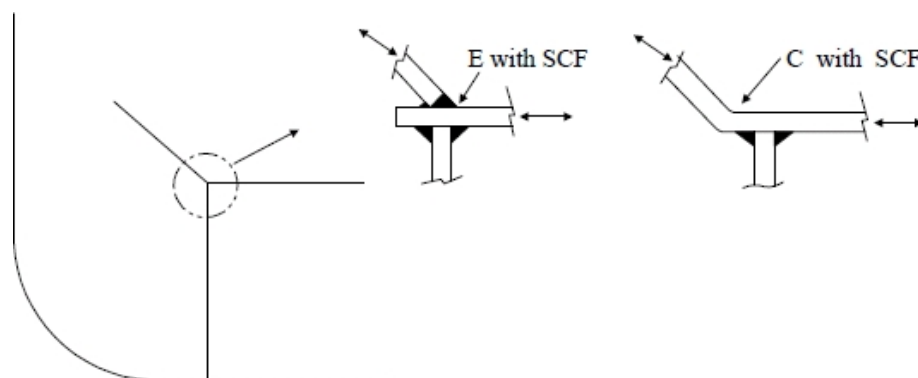

11.3.4 Connection Between Cofferdam Bulkhead and Inner Bottom

Fatigue class designation and SCF's may be determined as shown in 3-A1/11.3.4 FIGURE 11 below.

FIGURE 11

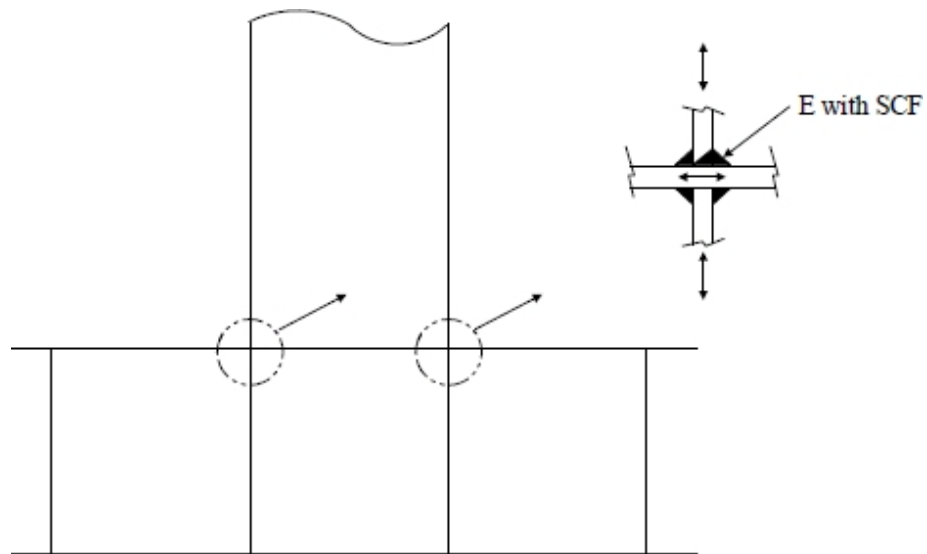

11.3.5 Doublers and Non-load Carrying Members on Deck or Shell Plating

Fatigue class designation may be determined as shown in 3-A1/11.3.5 FIGURE 12.

FIGURE 12
Doublers and Non-load Carrying Members on Deck or Shell Plating

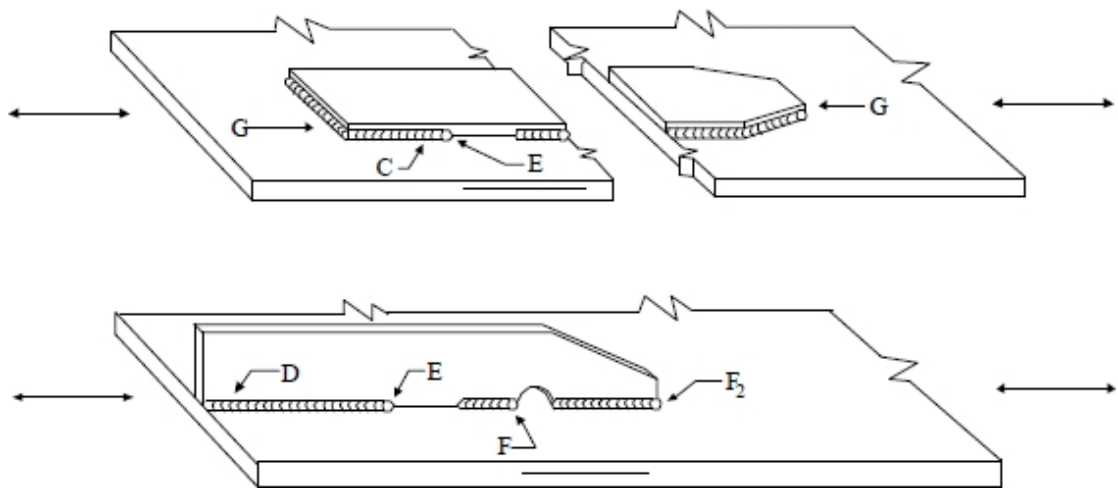

13 Stress Concentration Factors Determined From Finite Element Analysis

13.1 Introduction

S-N data and stress concentration factors (SCF's) are related to each other and therefore should be considered together so that there is a consistent basis for the fatigue assessment.

The following guidance is intended to assist the designer.

13.3 S-N Data

S-N data are presented as a series of straight-lines plotted on log-log scale. The data reflect the results of numerous tests, which often display considerable scatter. The recommended design curves for different

types of structural details and welded connections recognize the scatter in test results in that the design curves have been based on the selection of the lower bound, 95% confidence limit. In other words, about 2.5% of the test failure results fall below this curve. Treating the design curve in this manner introduces a high, yet reasonable degree of conservatism in the design and fatigue evaluation processes.

Individual S-N curves are presented to reflect certain generic structural geometry or arrangements. 3-A1/3.3.13 TABLE 1 and 3-A1/11.3 contain sketches of weld connections and other details typically found in floating terminal structures, giving a list of the S-N classification. This information is needed to assess the fatigue strength of a detail. Also needed is a consistent way to establish the demands or load effects placed on the detail, so that a compatible assessment can be made of the available strength versus the demand. Here is where interpretation and judgment enter the fatigue assessment.

S-N curves are obtained from laboratory sample testing. The applied reference stress on the sample which is used to establish the S-N data is referred to as the nominal stress. The nominal stress is established in a simple manner, such as force divided by area and bending moment divided by section modulus (P/A & M/SM). The structural properties used to establish the nominal stress are taken from locations away from any discontinuities to exclude local stress concentration effects arising from the presence of a weld or other local discontinuity. In an actual structure, it is rare that a match will be found with the tested sample geometry and loading. One is then faced with the problem of making the appropriate interpretation.

13.5 S-N Data and SCF's

Selection of appropriate S-N data appears to be rather straightforward with respect to “standard details” offered in 3-A1/3.3.13 TABLE 1 or other similar reference. However, in the case of welded connections in complex structures, it is required that SCF's be used to modify the nominal stress range. An often quoted example of the need to modify nominal stress for fatigue assessment purposes is one shown in 3-A1/13.5 FIGURE 13 below, relating to a hole drilled in the middle of a flat plate traversed by a butt weld.

In this example, the nominal stress S_N is $P/Area$, but the stress to be used to assess the fatigue strength at point A is S_A or $S_N \cdot SCF$. This example is deceptively simple because it does not tell the entire story. The most obvious deficiency of the example is that one needs to have a definitive and consistent basis to obtain the SCF. There are reference books, which indicate that based on the theory of elasticity, the SCF to be applied in this case is 3.0. However, when the SCF is computed using the finite element analysis techniques, the SCF obtained can be quite variable depending on the mesh size. The example does not indicate which S-N curve should be applied, nor does the example say how it may be necessary to alter the selection of the design S-N data in consideration of the aforementioned finite element analysis issues. Therefore, if such interpretation questions exist for a simple example, the higher difficulty of appropriately treating more complex structures should be evident.

Referring to the S-N curves to be applied to welded connections (for example S-N curves D-W in 3-A1/5.7 FIGURE 5), the SCF's resulting from the presence of the weld itself are already accounted for in these curves. If one were to have the correct stress distribution in the region - from the weld to a location sufficiently away from the weld toe (where the stress is suitably established by the nominal stress obtained from P/A and M/SM) - the stress distribution may be generically separated into three distinct segments, as shown in 3-A1/13.5 FIGURE 14 below.

- Region III is a segment where the stress gradient is controlled by the nominal stress gradient.
- Region II is a segment where the nominal stress gradient is being modified due to the presence of other structure, such as the bracket end shown in the figure. This must be accounted for to obtain an appropriate stress to be used in the fatigue analysis at the weld toe.
- Region I is a segment where the stress gradient is being modified due to the presence of the weld metal itself. The stress concentration due to the weld is already accounted for in the S-N design curve and will not be discussed further. Since the typical way to determine the stress distribution is via planar/linear elements, which ignore the weld, this is consistent with the method of analysis.

This general description of the stress distribution is again inconclusive because one does not know in advance and with certainty the distances from the weld toe to where the indicated changes of slope for the stress gradient occur. For this reason, definite rules need to be established to determine the slopes and with this knowledge, criteria established to be used to find the stress at the weld toe which should be used in the fatigue assessment.

In this regard, two approaches can be used to find the stress at the weld toe, which reflect two methods of structural idealization. One of these arises from the use of a conventional beam element idealization of the structure including the end bracket connection, and the other arises from the use of a fine mesh finite element idealization.

Using a beam element idealization, the nominal stress at any location (i.e., P/A and M/SM) can be obtained. (See 3-4/Figure 4 for a sample beam element model).

In the beam element idealization, there will be questions as to whether or not the geometric stress concentration due to the presence of other structure is adequately accounted for. This is the “Segment II” stress gradient previously described. In the beam modeling approach shown in the figure, the influence on stresses arising from the “carry over” of forces and bending moments from adjacent structural elements has been accounted for (albeit approximately). At the same time, the strengthening effect of the brackets has been conservatively ignored. Hence for engineering purposes, this approach is considered to be sufficient in conjunction with the nominal stress obtained at the location of interest and the nominal S-N curve, i.e., the F or F₂ Class S-N data, as appropriate.

In the fine mesh finite element analysis approach, one needs to define the element size to be used. This is an area of uncertainty because the calculated stress distribution can be unduly affected by both the employed mesh size and the uniformity of the mesh adjacent to the weld toe. Therefore, it is necessary to establish “rules” as given below to be followed in the producing of the fine mesh model adjacent to the weld toe. Furthermore, since the area adjacent to the weld toe (or other discontinuity of interest) may be experiencing a large and rapid change of stress (i.e. a high stress gradient), it is also necessary to provide a rule which can be used to establish the stress at the location where the fatigue assessment is to be made.

3-A1/13.5 FIGURE 15 shows an acceptable method which can be used to extract and interpret the “near weld toe” element stresses and to obtain a (linearly) extrapolated stress at the weld toe. When plate or shell elements are used in the modeling, it is recommended that each element size is to be equal to the plate thickness. When stresses are obtained in this manner, the use of the E Class S-N data is considered to be acceptable.

Weld hot spot stress can be determined from linear extrapolation of surface component stresses at $t/2$ and $3t/2$ from weld toe. The principal stresses at hot spot are then calculated based on the extrapolated stresses and used for fatigue evaluation. Description of the numerical procedure is given in 3-A1/13.7 below.

FIGURE 13

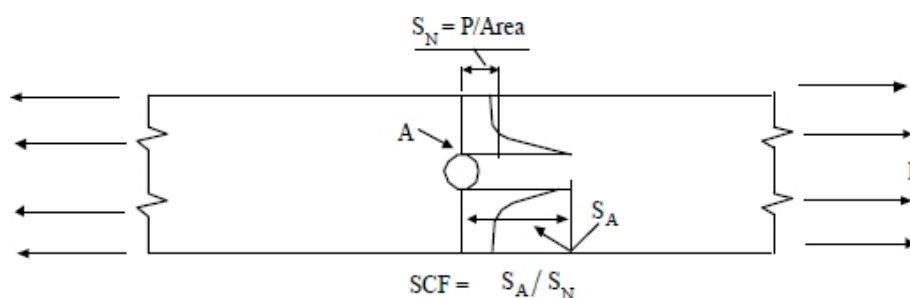

FIGURE 14

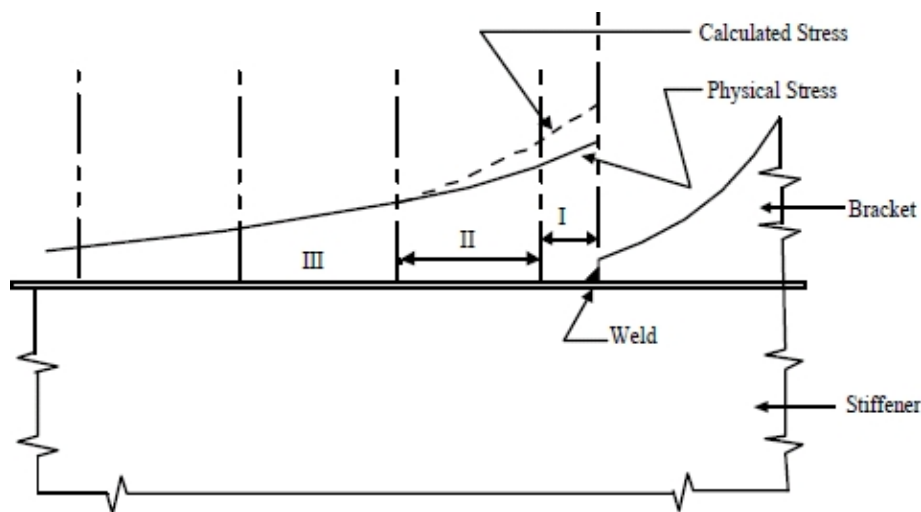
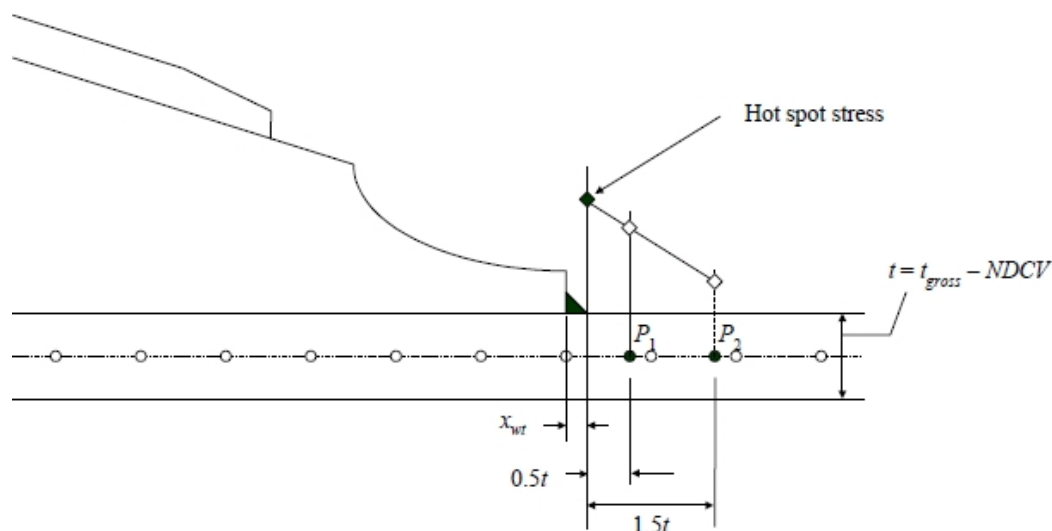

FIGURE 15



13.7 Calculation of Hot Spot Stress for Fatigue Analysis

The following method is applied to obtain the hot spot stress at the toe of a weld.

A very fine mesh is to be used in the region of the hotspot stress with a mesh size equal to plate thickness. The hot spot stress is to be determined by using a linear extrapolation as described in 3-A1/13.5 FIGURE 15. Assuming that the applicable surface component stresses of the two points, P_1 and P_2 , measured by the distances $0.5t$ and $1.5t$ from the weld toe, respectively, have been determined from FEM analysis by the linear interpolation of stresses at centroids of the adjacent two elements, the corresponding hot spot stress can be extrapolated at the hot spot location from the stresses at P_1 and P_2 . The weld toe distance, x_{wt} , is not to be taken larger than $0.5t_{gross}$.

15 Fatigue Assessment of Structures Considering Low Cycle Fatigue

15.1 Introduction

Certain duty cycles associated with operations of a floating offshore liquefied gas terminal may produce oscillatory stresses whose magnitudes exceed the yield strength of the material. For welded joints in

certain members of floating liquefied gas terminals during the loading/offloading process, the total number of cycles during the service life is expected to be less than 10^4 . Fatigue associated with cyclic plasticity (“low cycle fatigue”) is addressed in the following sections. The appropriate low cycle fatigue design S-N curve is defined, the process for computing oscillatory pseudo stress is provided, and the acceptance criterion for total damage, low cycle plus high cycle fatigue, is specified.

15.3 Applicability

3-A1/15 and 3-A1/17 define the procedure for a simplified fatigue assessment which is to be used to evaluate the fatigue strength of critical structural details subjected to low cycle fatigue. The fatigue assessment uses a hot spot stress approach based on FE analysis.

15.5 Loads

Traditionally, the fatigue strength analysis considers the following dynamic loads (high cycle load) for calculation of the long term distribution of stresses:

- Hull girder loads (i.e., vertical and horizontal wave bending moments)
- Dynamic wave pressure
- Dynamic tank pressure loads resulting from the floating terminal’s motion

However, from low cycle fatigue point of view, fatigue due to the following static loads need to be considered:

- Static cyclic loads due to cargo loading and offloading

15.7 Selection of Loading Conditions for Low Cycle Fatigue

Fatigue analyses are to be carried out for representative loading conditions according to the intended terminal’s operation. The following two loading conditions are to be examined:

- i)* For locations at longitudinal end connections:
- Full load condition with design still water bending moment, see loading condition 4 in 3-A1/7.5.2 FIGURE 6
 - Ballast or light draft condition with design still water bending moment, see loading condition 1 in 3-A1/7.5.2 FIGURE 6

- ii)* For locations other than longitudinal end connections:

The maximum low cycle fatigue damage calculated from the following two pairs:

Pair 1

- Full load condition with design still water bending moment, see loading condition 4 in 3-A1/7.5.2 FIGURE 6
- Ballast or light draft condition with design still water bending moment, see loading condition 1 in 3-A1/7.5.2 FIGURE 6

Pair 2

- Intermediate condition with design still water bending moment, see loading condition 3 in 3-A1/7.5.2 FIGURE 6
- Intermediate condition with design still water bending moment, see loading condition 2 in 3-A1/7.5.2 FIGURE 6

15.9 Acceptance Criteria

The criteria stated in 3-A1/15 and 3-A1/17 are presented as a comparison of fatigue strength of the structural detail (capacity), and fatigue inducing loads (demands), in the form of a fatigue damage parameter, DM . The combined fatigue damage including damages from both low cycle fatigue and high cycle fatigue, DM_{comb} , is to be less than or equal to 1.0 for the design life of the floating terminal, which is not to be taken as less than 20 years.

15.11 Fatigue Assessment Methods

The hot spot stress approach is to be used for fatigue evaluation of the following details:

15.11.1 Connections of Longitudinal Stiffeners to Transverse Web/Floor and to Transverse Bulkhead

15.11.1(a) Two (2) to three (3) selected side longitudinals in the region from the 1.1 draft to about $\frac{1}{3}$ draft in the midship region and also in the region between $0.15L$ and $0.25L$ from F.P., respectively.

15.11.1(b) One (1) to two (2) selected longitudinals from each of the following groups:

- Deck longitudinals, bottom longitudinals, inner bottom longitudinals and longitudinals on side longitudinal bulkheads
- One longitudinal on each of the longitudinal bulkheads within $0.1D$ from the deck is to be included

For these structural details, the fatigue assessment is to be first focused on the flange of the longitudinal at the rounded toe welds of attached flat bar stiffeners and brackets, as illustrated for Class F item 2) and Class F₂ item 1) in 3-A1/3.3.13 TABLE 1.

Then, the critical spots on the web plate cut-out, on the lower end of the stiffener as well as the weld throat are also to be checked for the selected structural detail. For illustration, see 3-A1/11.3.1 and 3-A1/11.3.2(a), 3-A1/11.3.2(b), and 3-A1/11.3.2(c).

Where the longitudinal stiffener end bracket arrangements are different on opposing sides of a transverse web, both configurations are to be checked.

15.11.2 Shell, Bottom, Inner Bottom or Bulkhead Plating at Connections to Webs or Floors (for Fatigue Strength of Plating)

15.11.2(a) One (1) to two (2) selected locations of side shell plating near the summer LWL amidships and between $0.15L$ and $0.25L$ from F.P. respectively

15.11.2(b) One (1) to two (2) selected locations in way of bottom and inner bottom amidships

15.11.2(c) One (1) to two (2) selected locations of lower strakes of side longitudinal bulkhead amidships

15.11.3 Connections of the Slope Plate to Inner Bottom and Side Longitudinal Bulkhead Plating at the Lower Cargo Tank Corners

One selected location amidships at transverse web and between webs, respectively

For this structural detail, the value of f_R , the total stress range as specified in 3-A1/9.1, is to be determined from fine mesh F.E.M. analyses for the combined load cases.

15.11.4 End Bracket Connections for Transverses and Girders

One (1) to two (2) selected locations in the midship region for each type of bracket configuration.

15.11.5 Other Regions and Locations

Other regions and locations, highly stressed by fluctuating loads, as identified from structural analysis.

17 Low Cycle Fatigue Damage

17.1 Low Cycle Fatigue Load

When fatigue is of concern, structural responses are assumed to result from two external sources, the wave loading on the terminal and the process of loading and offloading the terminal resulting in uneven buoyancy. This loading/offloading process produces very low frequency static loads including oscillatory still-water bending moment (SWBM) and still-water pressure. Some structural components experience cyclic plasticity when the combination of the two load sources produces cyclic stresses that exceed the yield strength of the material. Typically this occurs at the toe of a weld. Described in this section is the process of defining damage due to low cycle fatigue.

17.3 Loading Conditions

Static cyclic loads including still-water bending moments and static pressure due to cargo loading and offloading are considered.

17.5 Stress Range Calculation

17.5.1 Elastic Hot Spot Stress Range Calculation (2018)

In the following, all reference to stress is to be interpreted as the elastic hot spot stress at the toe of a weld in question. Also, at the outset, it will be assumed that the S-N curve defining fatigue strength is given in pseudo hot spot stress. In the elastic high cycle range a pseudo hot spot stress will be the same as an elastic hot spot stress. They will differ in the low cycle range.

As shown in 3-A1/17.5.1 FIGURE 16, the stress process in certain structural components of a floating terminal can be considered as a superposition of wave induced stresses, $S_W(t)$, and stresses associated with static load, S_B . The cycles of S_B result from the loading/offloading process.

The total or net stress process will be:

$$S(t) = S_B(t) + S_W(t)$$

FIGURE 16
 Sample Functions of S_W and S_B

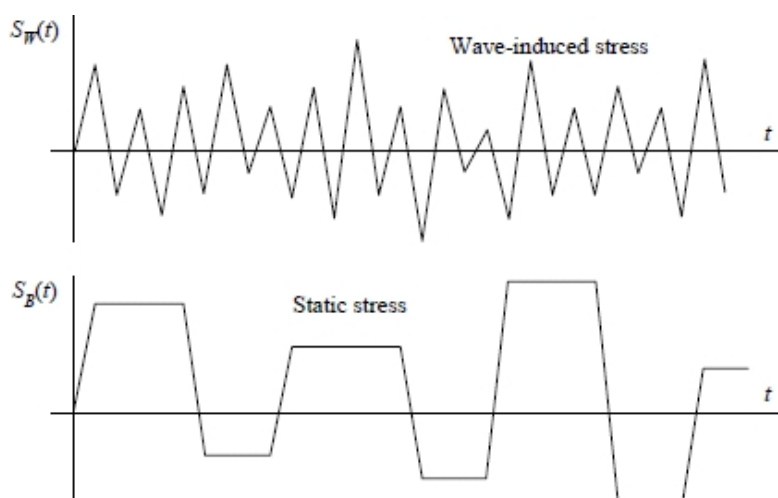
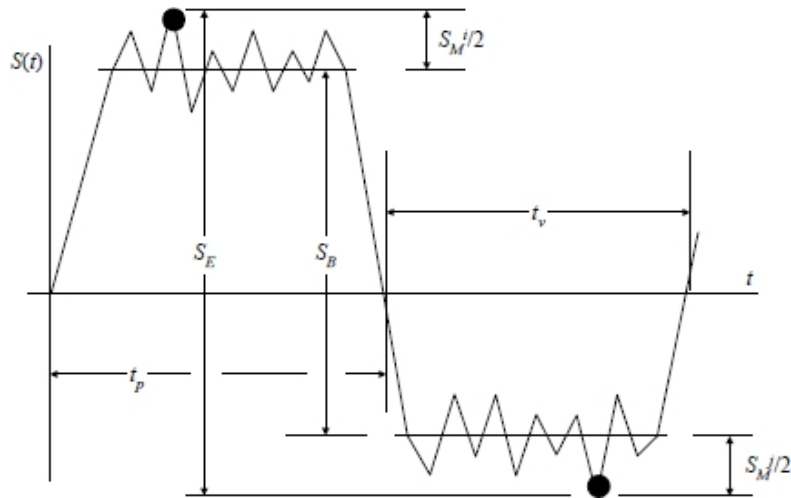

FIGURE 17
A Single Loading/Offloading Cycle



In one cycle of the static process, as shown in 3-A1/13.5 FIGURE 13, the total stress range associated with this cycle is S_E ,

$$S_E = S_B + 0.5(S_M^i + S_M^j)$$

where

S_B = static stress range for this cycle

S_M^i = median of the largest stress range of wave induced load for i – th load condition

S_M^j = median of the largest stress range of wave induced load for j – th load condition

From extreme value theory, the median largest stress range S_M^i in n cycles is given as:

$$\frac{S_M^i}{\delta} = [-1n(1 - 0.5^{1/n})]^{1/\gamma}$$

where γ and δ are the long term stress shape and scale factors, respectively. δ can be determined statistically from long term records of stress ranges or can be calculated by the formula:

$$\delta = \frac{f_R}{[1n(N_s)]^{1/\gamma}}$$

where f_R is the stress range associated with a probability of exceedance of $1/N_s$, as defined in 3-A1/9.1, and N_s is equal to 10^4 .

n may be computed by taking the estimated time for a half cycle divided by the estimated wave period.

The number of cycles for the terminal's loading and unloading, n_{LCF} , is assumed to be no less than 1200 for 20 years. The actual cycles of loading/offloading may be used for historical sites in FPSO phase.

Assume there are 10^8 wave cycles within 20 years, n is then equal to:

$$\frac{10^8}{n_{LCF} \times 2}$$

In general, it is expected that the time in tension will not equal the time in compression. For a conservative analysis, the larger of the two might be selected.

17.5.2 Pseudo Hot Spot Stress Range Calculation

To transform elastic hot spot stress range to pseudo hot spot stress range, a plasticity correction factor, k_e , is defined as:

$$k_e = \frac{S_L}{S_E}$$

where S_L is the pseudo hot spot stress range.

A plot of k_e as a function of S_E is given in 3-A1/17.5.2 FIGURE 18.

FIGURE 18
 k_e as a Function of S_E

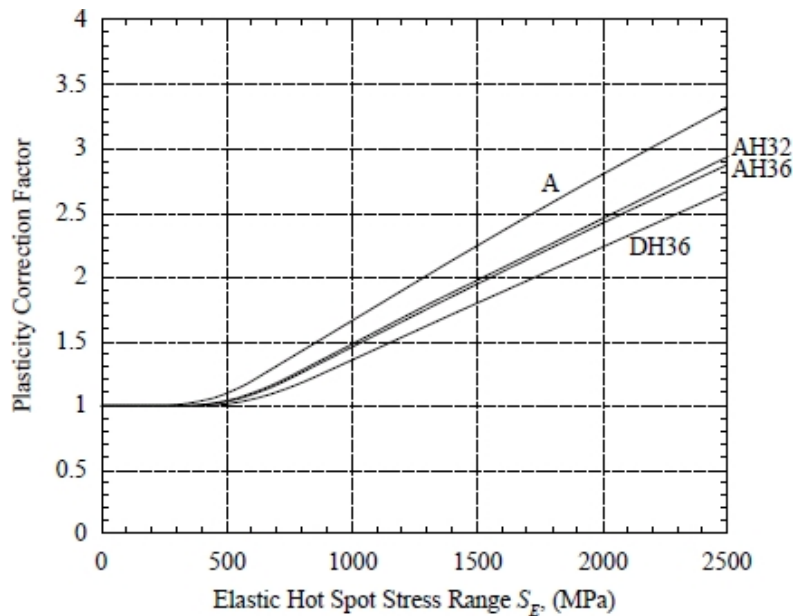

An approximate analytical formula derived from 3-A1/17.5.2 FIGURE 18 can be used:

$$k_e = 0.5 + k_m S_E, \text{ but should not be less than } 1.0$$

Values of k_m

Material	Mild	HT32	HT36	HT40
k_m	11.20×10^{-4}	9.60×10^{-4}	9.40×10^{-4}	8.56×10^{-4}

17.5.3 Low Cycle S-N Curve and Damage Calculation (2018)

The design S-N curve in the low cycle region is defined in 3-A1/17.5.3 FIGURE 19. It may be considered to be a modified D-Curve.

The low cycle fatigue (LCF) design S-N curve is given as:

$$NS^q = B \quad \text{for } 100 < N < 10^4$$

where

$$q = 2.4$$

$$B = 3.51 \times 10^{10} \text{ (MPa units)}$$

It is assumed that the LCF design S-N curve is applicable to static induced stresses. Basic application of Miner's rule produces the expression of static stress damage DM_{LCF} is:

$$DM_{LCF} = \frac{n_{LCF} S_L^q}{B}$$

n_{LCF} is the total cycles of loading/offloading, which is not to be less than 1200 for a floating liquefied gas terminal to be operated for 20 years. The actual cycles of loading/offloading may be used for historical sites in FPSO phase.

FIGURE 19
Low Cycle Fatigue Design Curve

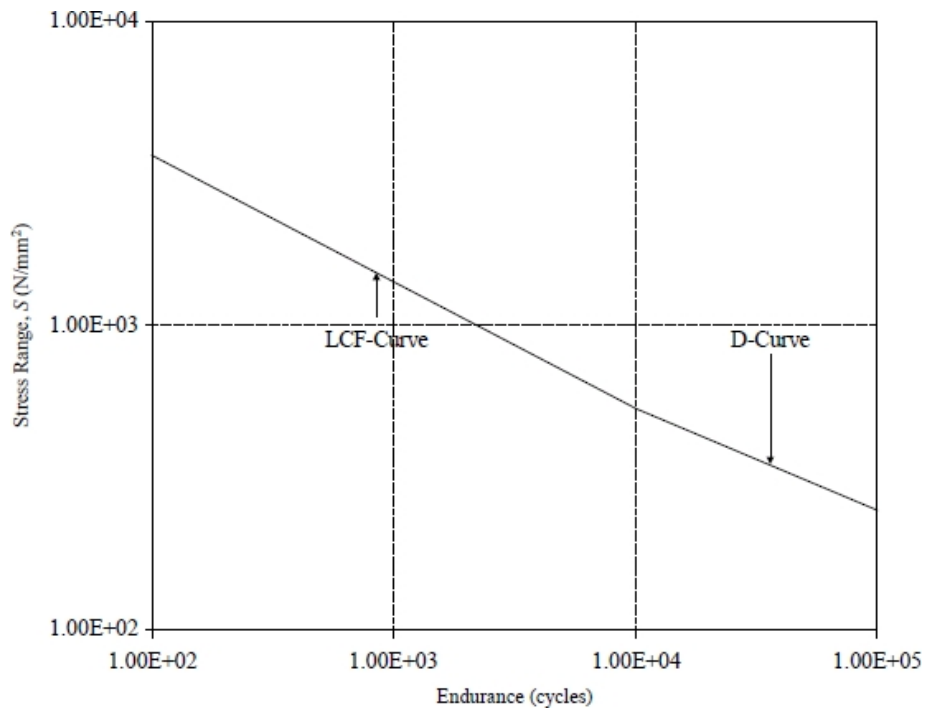

19 Combined Fatigue Damage

The total fatigue damage due to both low cycle and high cycle stress can be calculated by

$$DM_{comb} = \frac{(DM_{LCF}^2 + 2\delta DM_{LCF} DM_{HCF} + DM_{HCF}^2)}{\sqrt{DM_{LCF}^2 + DM_{HCF}^2}}$$

where

- δ = 0.02
- DM_{LCF} = low cycle fatigue damage
- DM_{HCF} = high cycle fatigue damage

For Longitudinal Stiffener Connections, the total fatigue damage due to both low cycle and high cycle stress can be calculated by

$$DM_{comb} = \frac{(DM_{LCF}^2 + 2\delta DM_{LCF}DM_{HCF}/\alpha_{Site} + (DM_{HCF}/\alpha_{Site})^2)}{\sqrt{DM_{LCF}^2 + (DM_{HCF}/\alpha_{Site})^2}}$$

where

- α_{Site} = environmental severity factor for the intended site, see 3-A3/5

CHAPTER 3 Structural Design Requirements

APPENDIX 2 Calculation of Critical Buckling Stresses

1 General

The critical buckling stresses for various structural elements and members may be determined in accordance with this Appendix or other recognized design practices. Critical buckling stresses derived from experimental data or analytical studies may be considered, provided that well-documented supporting data are submitted for review.

3 Rectangular Plates

The critical buckling stresses for rectangular plate elements, such as plate panels between stiffeners; web plates of longitudinals, girders, floors and transverses; flanges and face plates, may be obtained from the following equations, with respect to uniaxial compression, bending and edge shear, respectively.

$$f_{ci} = f_{Ei} \quad \text{for } f_{Ei} \leq P_r f_{yi}$$

$$f_{ci} = f_{yi} [1 - P_r (1 - P_r) f_{yi} / f_{Ei}] \quad \text{for } f_{Ei} > P_r f_{yi}$$

where

- f_{ci} = critical buckling stress with respect to uniaxial compression, bending or edge shear, separately, N/cm² (kgf/cm², lbf/in²)
- f_{Ei} = $K_i [\pi^2 E / 12 (1 - \nu^2)] (t_n / s)^2$, N/cm² (kgf/cm², lbf/in²)
- K_i = buckling coefficient, as given in 3-A2/Table 1
- E = modulus of elasticity of the material, may be taken as 2.06×10^7 N/cm² (2.1×10^6 kgf/cm², 30×10^6 lbf/in²) for steel
- ν = Poisson's ratio, may be taken as 0.3 for steel
- t_n = net thickness of the plate, in cm (in.)
- s = spacing of longitudinals/stiffeners, in cm (in.)
- P_r = proportional linear elastic limit of the structure, may be taken as 0.6 for steel
- f_{yi} = f_y , for uniaxial compression and bending

$$= f_y / \sqrt{3}, \text{ for edge shear}$$

$$f_y = \text{specified minimum yield point of the material, in N/cm}^2 \text{ (kgf/cm}^2, \text{ lbf/in}^2\text{)}$$

TABLE 1
Buckling Coefficient, K_i

For Critical Buckling Stress Corresponding to f_L, f_T, f_b or f_{LT}

I. Plate panel between stiffeners

A Uniaxial compression

1. Long plate
 $\ell \geq s$

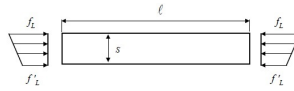

- a. For $f'_L = f_L$: $4C_1$,
 b. For $f'_L = f_L/3$: $5.8C_1$,
 (see note)

K_i

2. Wide plate
 $\ell \geq s$

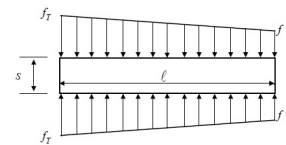

- a. For $f'_T = f_T$: $[1 + (s/\ell)^2]^2 C_2$
 b. For $f'_T = f_T/3$: $1.45[1 + (s/\ell)^2]^2 C_2$
 (see note)

B Ideal Bending

1. Long plate
 $\ell \geq s$

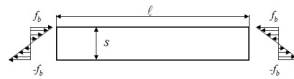

$24C_1$

2. Wide plate
 $\ell \geq s$

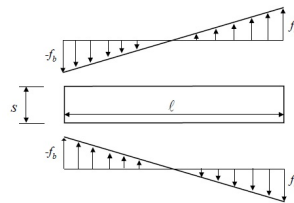

- a. For $1.0 \leq \ell/s \leq 2.0$: $24(s/\ell)^2 C_2$
 b. For $2.0 < \ell/s$: $12(s/\ell) C_2$

C Edge Shear

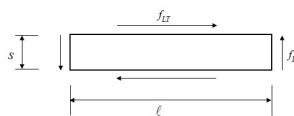

K_i

$$[5.34 + 4(s/\ell)^2] C_1$$

D Values of C_1 and C_2

1. For plate panels between angles or tee stiffeners

$$C_1 = 1.1$$

$$C_2 = 1.3 \text{ within the double bottom or double side*}$$

$$C_2 = 1.2 \text{ elsewhere}$$

2. For plate panels between flat bars or bulb plates

$$C_1 = 1.0$$

$$C_2 = 1.2 \text{ within the double bottom or double side*}$$

$$C_2 = 1.1 \text{ elsewhere}$$

* applicable where shorter edges of a panel are supported by rigid structural members, such as bottom, inner bottom, side shell, inner skin bulkhead, double bottom floor/girder and double side web stringer.

<p>II. Web of Longitudinal or Stiffener</p> <p>A Axial compression Same as I.A.1 by replacing s with depth of the web and ℓ with unsupported span</p> <p>a. For $f'_L = f_L$: b. For $f'_L = f_L/2$: (see note)</p> <p>where $C = 1.0$ for angle or tee stiffeners $C = 0.33$ for bulb plates $C = 0.11$ for flat bars</p> <p>B Ideal Bending Same as I.B.1 by replacing s with depth of the web and ℓ with unsupported span</p>	<p>K_i</p> <p>$4C$ $5.2C$</p> <p>$24C$</p>
<p>III. Flange and Face Plate</p> <p>Axial Compression</p>	<p>K_i</p> <p>0.44</p>



$s = b_2$
 $\ell =$ unsupported span

Note: In I.A. (II.A), K_i for intermediate values of $f'_L/f_L(f'_T/f_T)$ may be obtained by interpolation between a and b.

5 Longitudinals and Stiffeners

5.1 Axial Compression

The critical buckling stress, f_{ca} , of a beam-column, i.e., the longitudinal and the associated effective plating, with respect to axial compression may be obtained from the following equations:

$$f_{ca} = f_e \quad \text{for } f_E \leq P_r f_y$$

$$f_{ca} = f_y [1 - P_r (1 - P_r) f_y / f_E] \quad \text{for } f_E > P_r f_y$$

where

$$f_E = \pi^2 E / (\ell / r)^2 \text{ N/cm}^2 \text{ (kgf/cm}^2, \text{ lbf/in}^2)$$

$$\ell = \text{ unsupported span of the longitudinal or stiffener, in cm (in.), as defined in 3-4/Figure 3}$$

$$r = \text{ radius of gyration of area } A_e, \text{ in cm (in.)}$$

$$A_e = A_s + b_w l t_n$$

- A_s = net sectional area of the longitudinals or stiffeners excluding the associated plating, cm² (in²)
- b_{wL} = effective width of the plating as given in 3-5/5.3.2, in cm (in.)
- t_n = net thickness of the plating, in cm (in.)
- f_y = minimum specified yield point of the longitudinal or stiffener under consideration, N/cm² (kgf/cm², lbf/in²)

P_r and E are as defined in 3-A2/3.

5.3 Torsional/Flexural Buckling

The critical torsional/flexural buckling stress with respect to axial compression of a longitudinal, including its associated plating (effective width, b_{wL}), may be obtained from the following equations:

$$f_{ct} = f_{ET} \quad \text{for } f_{ET} \leq P_r f_y$$

$$f_{ct} = f_y [1 - P_r(1 - P_r) f_y / f_{ET}] \quad \text{for } f_{ET} > P_r f_y$$

where

- f_{ct} = critical torsional/flexural buckling stress with respect to axial compression, N/cm² (kgf/cm², lbf/in²)
- f_{ET} = $E[K/2.6 + (n\pi/\ell)^2\Gamma + C_o(\ell/n\pi)^2/E]/I_o[1 + C_o(\ell/n\pi)^2/I_o f_{cl}]$, N/cm² (kgf/cm², lbf/in²)
- K = St. Venant torsion constant for the longitudinal's cross section, excluding the associated plating.
- $$= [b_f t_f^3 + d_w t_w^3]/3$$
- I_o = polar moment of inertia of the longitudinal, excluding the associated plating, about the toe (intersection of web and plating), in cm⁴ (in⁴)
- $$= I_x + mI_y + A_s(x_o^2 + y_o^2)$$
- I_x, I_y = moment of inertia of the longitudinal about the x - and y -axis, respectively, through the centroid of the longitudinal, excluding the plating (x -axis perpendicular to the web), in cm⁴ (in⁴)
- m = $1.0 - u(0.7 - 0.1d_w/b_f)$
- u = unsymmetry factor
- $$= 1 - 2b_1/b_f$$
- x_o = horizontal distance between centroid of stiffener, A_s , and centerline of the web plate, cm (in.)
- y_o = vertical distance between the centroid of the longitudinal's cross section and its toe, cm (in.)
- d_w = depth of the web, cm (in.)
- t_w = net thickness of the web, cm (in.)
- b_f = total width of the flange/face plate, cm (in.)
- b_1 = smaller outstanding dimension of flange with respect to centerline of web (see 3-A2/Figure 1), cm (in.)
- t_f = net thickness of the flange/face plate, cm (in.)
- C_o = $E t_n^3 / 3s$
- Γ = warping constant

$$\cong mI_{yf}d_w^2 + d_w^3t_w^3/36$$

$$I_{yf} = t_f b_f^3(1.0 + 3.0u^2d_w t_w/A_s)12 \text{ cm}^4 (\text{in}^4)$$

$$f_{cl} = \text{critical buckling stress for the associated plating corresponding to } n\text{-half waves, N/cm}^2 (\text{kgf/cm}^2, \text{lbf/in}^2)$$

$$= \pi^2 E(n/\alpha + \alpha/n)^2 (t_n/s)^2 / 12(1 - \nu^2)$$

$$\alpha = \ell/s$$

$$n = \text{number of half-wave which yield a smallest } f_{ET}$$

$$f_y = \text{minimum specified yield point of the longitudinal or stiffener under consideration, N/cm}^2 (\text{kgf/cm}^2, \text{lbf/in}^2)$$

P_r, E, s and ν are as defined in 3-A2/3.

A_s, t_n and ℓ are as defined in 3-A2/5.1.

FIGURE 1
Net Dimensions and Properties of Stiffeners

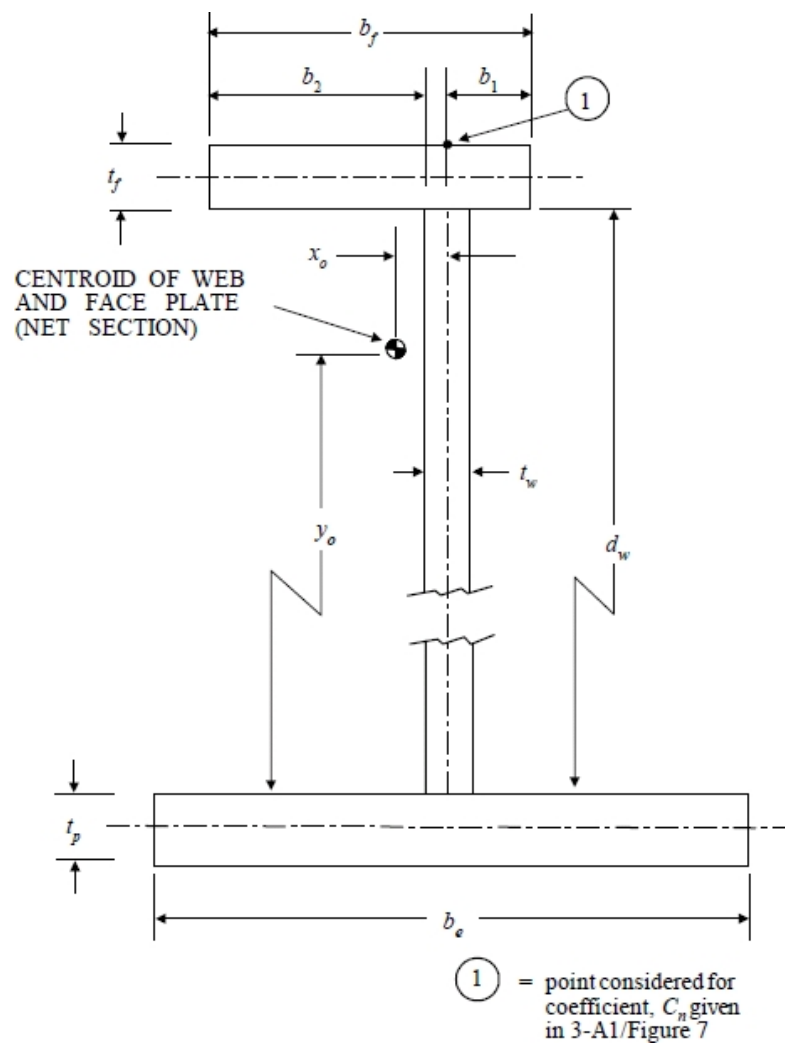

7 Stiffened Panels

7.1 Large Stiffened Panels

For large stiffened panels between bulkheads or panels stiffened in one direction between transverses and girders, the critical buckling stresses with respect to uniaxial compression may be determined from the following equations:

$$f_{ci} = f_{Ei} \quad \text{for } f_{Ei} \leq P_r f_y$$

$$f_{ci} = f_y [1 - P_r(1 - P_r)f_y / f_{Ei}] \quad \text{for } f_{Ei} > P_r f_y$$

where

$$f_{Ei} = k_L \pi^2 (D_L D_T)^{1/2} / t_L b^2 \quad \text{in the longitudinal direction, N/cm}^2 \text{ (kgf/cm}^2, \text{ lbf/in}^2)$$

$$f_{Ei} = k_T \pi^2 (D_L D_T)^{1/2} / t_T \ell^2 \quad \text{in the transverse direction, N/cm}^2 \text{ (kgf/cm}^2, \text{ lbf/in}^2)$$

$$k_L = 4 \quad \text{for } \ell/b \geq 1$$

$$= \left[1/\phi_L^2 + 2\eta + \phi_L^2 \right] \quad \text{for } \ell/b < 1$$

$$k_T = 4 \quad \text{for } b/\ell \geq 1$$

$$= \left[1/\phi_T^2 + 2\eta + \phi_T^2 \right] \quad \text{for } b/\ell < 1$$

$$D_L = EI_L / s_L (1 - \nu^2)$$

$$D_T = EI_T / s_T (1 - \nu^2)$$

$$D_T = Et_n^3 / 12 (1 - \nu^2) \quad \text{if no stiffener in the transverse direction}$$

$$\ell, b = \text{length and width between transverse and longitudinal bulkheads, respectively, cm (in.) (See 3-A2/Figure 2)}$$

$$t_L, t_T = \text{net equivalent thickness of the plating and stiffener in the longitudinal and transverse direction, respectively, cm (in.)}$$

$$= (s_L t_n + A_{sL}) / s_L \quad \text{or} \quad (s_T t_n + A_{sT}) / s_T$$

$$s_L, s_T = \text{spacing of longitudinals and transverses, respectively, cm (in.) (See 3-A2/Figure 2)}$$

$$\phi_L = (\ell/b)(D_T/D_L)^{1/4}$$

$$\phi_T = (b/\ell)(D_L/D_T)^{1/4}$$

$$\eta = [(I_{pL} I_{pT}) / (I_L I_T)]^{1/2}$$

$$A_{sL}, A_{sT} = \text{net sectional area of the longitudinal and transverse, excluding the associated plating, respectively, cm}^2 \text{ (in}^2)$$

$$I_{pL}, I_{pT} = \text{net moment of inertia of the effective plating alone (effective breadth due to shear lag) about the neutral axis of the combined cross section, including stiffener and plating, cm}^4 \text{ (in}^4)$$

$$I_L, I_T = \text{net moment of inertia of the stiffener (one) with effective plating in the longitudinal or transverse direction, respectively, cm}^4 \text{ (in}^4). \text{ If no stiffener, the moment of inertia is calculated for the plating only.}$$

f_y, P_r, E and ν are as defined in 3-A2/3. t_n is as defined in 3-A2/5.1.

With the exception of deck panels, when the lateral load parameter, q_o , defined below is greater than 5, reduction of the critical buckling stresses given above is to be considered.

$$q_o = p_n b^4 / (\pi^4 t_T D_T)$$

$$q_o = p_n \ell^4 / (\pi^4 t_L D_L)$$

where

p_n = average net lateral pressure, N/cm² (kgf/cm², lbf/in²)

$D_T, D_L, b, \ell, t_T, t_L$ and s_T are as defined above.

In this regard the critical buckling stress may be approximated by

$$f'_{ci} = R_o f_{ci} \quad \text{N/cm}^2 \text{ (kgf/cm}^2, \text{ lbf/in}^2\text{)}$$

where

$$R_o = 1 - 0.045(q_o - 5) \quad \text{for } q_o \geq 5$$

For deck panels, $R_o = 1.0$ and $f'_{ci} = f_{ci}$

FIGURE 2

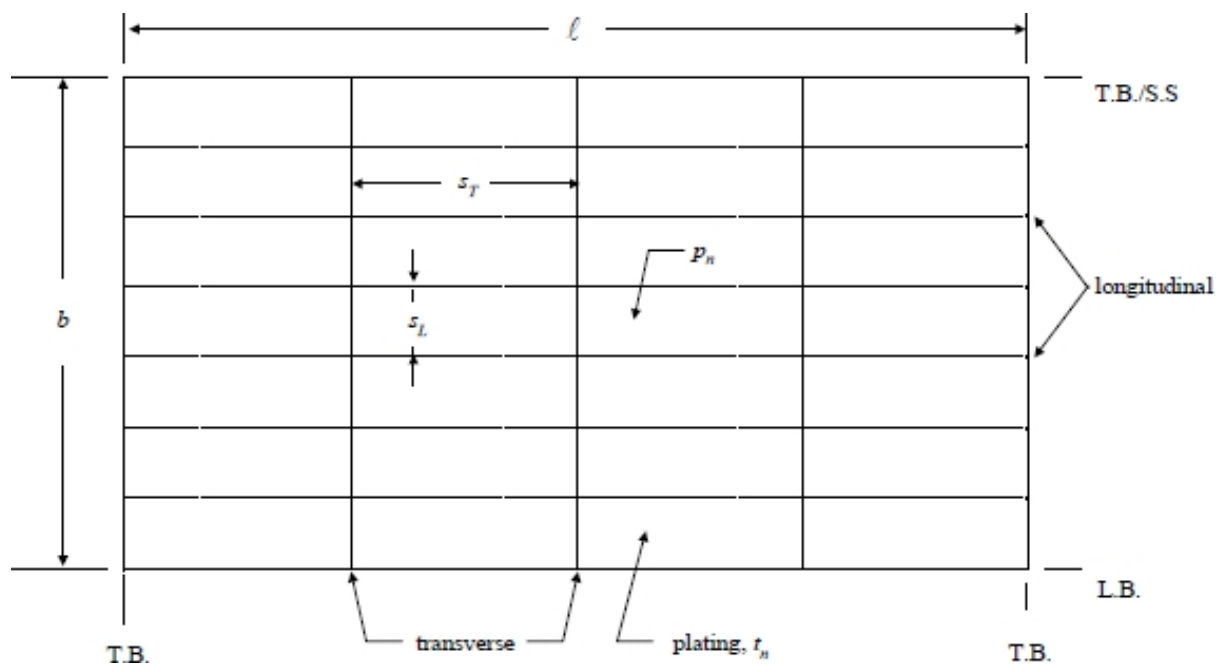

9 Girders, Webs and Stiffened Brackets

9.1 Critical Buckling Stresses of Web Plates and Large Brackets

The critical buckling stresses of web plates and large brackets between stiffeners may be obtained from the equations given in 3-A2/3 for uniaxial compression, bending and edge shear.

9.3 Effects of Cut-outs

The depth of cut-out, in general, is to be not greater than $d_w/3$, and the stresses in the area calculated are to account for the local increase due to the cut-out.

When cut-outs are present in the web plate, the effects of the cut-outs on reduction of the critical buckling stresses is to be considered, as outlined in the Subparagraphs below.

9.3.1 Reinforced by Stiffeners Around Boundaries of Cut-outs

When reinforcement is made by installing straight stiffeners along boundaries of the cut-outs, the critical buckling stresses of web plate between stiffeners with respect to compression and shear may be obtained from equations given in 3-A2/3.

9.3.2 Reinforced by Face Plates Around Contour of Cut-outs

When reinforcement is made by adding face plates along the contour of the cut-out, the critical buckling stresses with respect to compression, bending and shear may be obtained from equations given in 3-A2/3, without reduction, provided that the net sectional area of the face plate is not less than $8t_w^2$, where t_w is the net thickness of the web plate, and that depth of the cut-out is not greater than $d_w/3$, where d_w is the depth of the web.

9.3.3 No Reinforcement Provided

When reinforcement is not provided, the buckling strength of the web plate surrounding the cut-out may be treated as a strip of plate with one edge free and the other edge simply supported.

9.5 Tripping

To prevent tripping of deep girders and webs with wide flanges, tripping brackets are to be installed with a spacing generally not greater than 3 meters (9.84 ft).

Design of tripping brackets may be based on the force P acting on the flange as given by the following equation.

$$P = 0.02f_{cl}(A_f + \frac{1}{3}A_w)$$

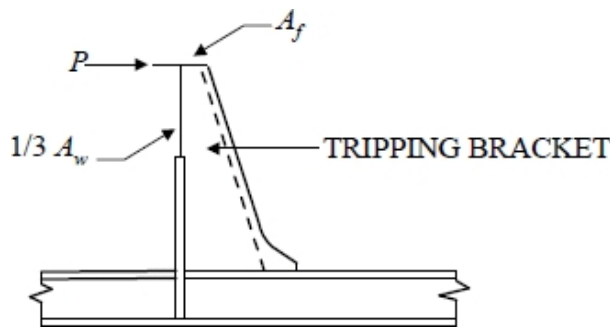

where

f_{cl} = critical lateral buckling stress with respect to axial compression between tripping brackets, N/cm² (kgf/cm², lbf/in²)

$f_{cl} = f_{ce}'$ for $f_{ce} \leq P_r f_y$
 $= f_y [1 - P_r (1 - P_r) f_y / f_{ce}]$, for $f_{ce} > P_r f_y$

$f_{ce} = 0.6E[(b_f/t_f)(t_w/d_w)^3]$ N/cm²(kgf/cm², lbf/in²)

A_f = net cross sectional area of the flange/face plate, in cm^2 (in^2)

A_w = net cross sectional area of the web, in cm^2 (in^2)

b_f, t_f, d_w, t_w are as defined in 3-A2/5.3.

E, P_r and f_y are as defined in 3-A2/3.

11 Stiffness and Proportions

To fully develop the intended buckling strength of the assemblies of structural members and panels, supporting elements of plate panels and longitudinals are to satisfy the following requirements for stiffness and proportion in highly stressed regions.

11.1 Stiffness of Longitudinals

The net moment of inertia of the longitudinals, i_o , with effective breadth of net plating, is to be not less than that given by the following equation:

$$i_o = \frac{st_n^3}{12(1-\nu^2)} \gamma_o \quad \text{cm}^4(\text{in}^4)$$

where

$$\gamma_o = (2.6 + 4.0\delta)\alpha^2 + 12.4\alpha - 13.2\alpha^{1/2}$$

$$\delta = A/st_n$$

$$\alpha = \ell/s$$

s = spacing of longitudinals, cm (in.)

t_n = net thickness of plating supported by the longitudinal, cm (in.)

ν = Poisson's ratio

= 0.3 for steel

A = net sectional area of the longitudinal (excluding plating), cm^2 (in^2)

ℓ = unsupported span of the longitudinal, cm (in.)

11.3 Stiffness of Web Stiffeners

The net moment of inertia, i , of the web stiffener, with the effective breadth of net plating not exceeding s or 0.33ℓ , whichever is less, is not to be less than obtained from the following equations:

$$i = 0.17\ell t^3 (\ell/s)^3 \quad \text{cm}^4(\text{in}^4) \quad \text{for } \ell/s \leq 2.0$$

$$i = 0.34\ell t^3 (\ell/s)^2 \quad \text{cm}^4(\text{in}^4) \quad \text{for } \ell/s > 2.0$$

where

ℓ = length of stiffener between effective supports, in cm (in.)

t = required net thickness of web plating, in cm (in.)

s = spacing of stiffeners, in cm (in.)

11.5 Stiffness of Supporting Members

The net moment of inertia of the supporting members, such as transverses and webs, is not to be less than that obtained from the following equation:

$$I_s/i_o \geq 0.2(B_s/\ell)^3(B_s/s)$$

where

I_s = moment of inertia of the supporting member, including the effective plating, cm⁴ (in⁴)

i_o = moment of inertia of the longitudinals, including the effective plating, cm⁴ (in⁴)

B_s = unsupported span of the supporting member, cm (in.)

ℓ and s are as defined in 3-A2/11.1.

11.7 Proportions of Flanges and Face Plates

The breadth-thickness ratio of flanges and face plates of longitudinals and girders is to satisfy the limits given below.

$$b_2/t_f = 0.4(E/f_y)^{1/2}$$

where

b_2 = larger outstanding dimension of flange, as given in 3-A2/5.3 FIGURE 1, cm (in.)

t_f = net thickness of flange/face plate, cm (in.)

E and f_y are as defined in 3-A2/3.

11.9 Proportions of Webs of Longitudinals and Stiffeners

The depth-thickness ratio of webs of longitudinals and stiffeners is to satisfy the limits given below.

$$d_w/t_w \leq 1.5(E/f_y)^{1/2} \quad \text{for angles and tee bars}$$

$$d_w/t_w \leq 0.85(E/f_y)^{1/2} \quad \text{for bulb plates}$$

$$d_w/t_w \leq 0.5(E/f_y)^{1/2} \quad \text{for flat bars}$$

where d_w and t_w are as defined in 3-A2/5.3 and E and f_y are as defined in 3-A2/3.

When these limits are complied with, the assumption on buckling control stated in 3-5/5.1.2(e) is considered satisfied. If not, the buckling strength of the web is to be further investigated, as per 3-A2/3.

CHAPTER 3 Structural Design Requirements

APPENDIX 3 Determination of Environmental Severity Factors

1 General

This Appendix provides information for the determination of Environmental Severity Factors (ESFs) for floating liquefied gas terminal design criteria to account for site-specific conditions compared to unrestricted service conditions.

The formulations from Chapter 3, Section 3 are modified to reflect the incorporation of various ESF β -types. In the modified formulations, the ESF (β) factors are applied to the dynamic load parameters in the load components.

The general concept of ESF α -types is to compare fatigue damage resulting from different environmental conditions. This type of ESF has two applications. First, it can be used to adjust the fatigue damage induced by the wave-induced dynamic loads at the terminal site. Second, it can be used to assess the fatigue damage accumulated during previous services as either a trading vessel or an existing floating liquefied gas terminal. The α -type ESFs are obtained at different locations for longitudinal stiffeners of the hull structure.

3 ESFs of the Beta (β) Type

This type of ESF is used to introduce a comparison of the severity between the intended environment and a base environment, which is the North Atlantic unrestricted service environment.

A presentation of formulations that are modified to reflect the incorporation of the various β ESFs is given in Chapter 3, Section 3. In the modified formulations, the β factors apply only to the dynamic portions of the load components, and the load components that are considered “static” are not affected by the introduction of the β factors.

The definition of the severity measure β is as follows:

$$\beta = \frac{Ls}{Lu}$$

where

- L_s = most probable extreme value based on the intended site (100 years return period), transit (10 years return period), and repair/inspection (1 year return period) environments for the dynamic load parameters specified in 3-A3/3 TABLE 1
- L_u = most probable extreme value base on the North Atlantic environment for the dynamic load parameters specified in 3-A3/3 TABLE 1

A β of 1.0 corresponds to the unrestricted service condition of a seagoing vessel. A value of β less than 1.0 indicates a less severe environment than the unrestricted case.

Extreme value analysis is to be performed for each dynamic load component to determine maximum value during the design life. Preference is given to an Extreme Value method that follows the so-called long-term approach commonly used for ship structure. However, the use of a validated short-term extreme value approach, which is appropriate to the terminal type and terminal site’s environmental data, will also be considered. The supplementary use of such a short-term approach to confirm or validate the sensitivity of the long-term based design values is encouraged. The result of the short-term approach cannot be used to reduce the long-term extreme value. If the short-term result is significantly larger, the long-term extreme value is to be further studied and validated. The environments specified for use in the short-term approach are “response based”, i.e., a 100-year design storm event is one that leads to the maximum responses expected to occur in 100-years. The return period is typically required to be 10 years for transit condition, and 1 year for repair and inspection conditions.

There are 13 dynamic load components in the ABS Rules for which the β adjustment factors have been derived. These are for the following dynamic loads or load effects:

TABLE 1
The 13 Dynamic Load Parameters or ESFs (β_{NN})

<i>No.</i>	<i>NN</i>	<i>Name</i>
1	VBM	Vertical Bending Moment
2	HBM	Horizontal Bending Moment
3	EPP	External Pressure Port
4	EPS	External Pressure Starboard
5	VAC	Vertical Acceleration
6	TAC	Transverse Acceleration
7	LAC	Longitudinal Acceleration
8	PMO	Pitch Motion
9	RMO	Roll Motion
10	RVM	Relative Vertical Motion at Forepeak
11	WHT	Wave Height
12	VSF	Vertical Shear Force
13	HSF	Horizontal Shear Force

As mentioned, the β values are a direct function of the long-term environmentally-induced loads at the floating terminal site compared to the unrestricted service environment that is the basis of the *Marine Vessel Rules*. The β values also need to address other differences and factors between the design basis of a sea going ship and a moored floating liquefied gas terminal. These include:

- i) Different design basis return periods for environmental loads (20 for unrestricted seagoing vs. 100 years for intended site, 10 years for transit and 1 year for repair/inspection condition).
- ii) Effects of mooring system on the predicted floating terminal load effects (including weathervaning type behavior of a turret moored system).
- iii) Different assumed wave energy spreading characterization between the open ocean and a site-specific situation.
- iv) Different basis of extreme design storm characterization (i.e., long-term winter storm vs. hurricane dominated characterization).
- v) Relative nearness of natural periods of global system response to significant environmentally-induced loadings at such periods (i.e., possible dynamic amplification effects).
- vi) Effects of shallow water on the predicted floating terminal motions and load effects

If a direct analysis of a floating offshore liquefied gas terminal were to be performed, the influences of the mentioned factors would need to be assessed and used in the terminal's design. It is not the intention of the alternative approach offered here to discourage direct analysis, but it is expected that the approach based on the use of the ESFs will still be used as an important basis of structural design/assessment of a floating liquefied gas floating terminal.

Note:

ABS intends to make computer software available to clients to help establish ESFs and a version of the ABS Eagle FLGT SEAS software that is modified to accommodate this concept. Clients are advised to contact ABS regarding the availability of this software.

Notwithstanding the listed β factors and their intended usage, it is still necessary to introduce a limit to prevent design parameters from being unrealistically low. This limit is that the result of an application of a β factor (e.g., in the calculation of a required scantling) is not to be less than 85 percent of the unrestricted service (Rule) value. The reasons for introducing this limit are to reflect successful service experience, a desire not to inadvertently create a reordering of the dominant structural failure modes, and to avoid the introduction of new controlling limit states (unacceptable deflections, vibrations, etc.).

It has also been necessary to introduce additional load cases or situations that reflect the relatively greater importance these cases may have for floating terminals with possibly reduced scantlings due to the calmer site conditions. Examples of these additional conditions are the more rigorous check of the tank test loading condition, inspection and repair conditions, and the hull strength assessment for the transit to site condition.

5 ESFs of the Alpha (α) Type

This type of ESF compares the fatigue damage between the specified environment and a base environment, which is the North Atlantic environment.

First, this type of ESF is used to adjust the expected fatigue damage induced from the dynamic components due to environmental loadings at the floating terminal's site. Second it can be used to assess the fatigue damage accumulated during the historical service either as a trading vessel or as an FPI, including both the historical site(s) and historical transit routes.

The definition of the severity measure α is as follows:

$$\alpha = \left(\frac{Du}{Ds} \right)^C$$

where

- D_u = annual fatigue damage based on the North Atlantic environment (unrestricted service) at the details of the hull structure
- D_s = annual fatigue damage based on a specified environment, for historical routes, historical sites, transit and intended site, at the details of the hull structure
- C = 0.65

For fatigue damage calculation, a closed form spectral-based fatigue analysis procedure can be used. The fundamental task of a spectral fatigue analysis is the determination of the stress transfer function, which express the relationship between the stress at a particular structural location per unit wave amplitude and wave frequency and heading. The stress transfer function needs to be determined from the load transfer function and its corresponding stress factor, which is a conversion factor to obtain the stress transfer function from the load transfer function. The load transfer function, which depends on hull form geometry, is to be calculated for regular waves of unit amplitude for ranges of wave frequencies and wave heading. The stress factor can be obtained through structural analysis techniques, which can be either a simple beam theory or finite element analysis procedures. The sophistication of the structural analysis needed depends on the physical system to be analyzed, the type of structural detail and the type of structural loading considered. For the longitudinal stiffener, the stress factors may be calculated by the simple beam theory.

The response spectra of the stress transfer functions can be determined by given wave spectra. In the ‘short-term closed form’ approach, the stress range is normally expressed in terms of probability density functions for different short-term sea states. These short-term probability density functions are derived by a spectral approach based on the Rayleigh distribution method whereby it is assumed that the variation of stress is a narrow banded random Gaussian process. When a narrow banded assumption is not valid for the stress process, a damage correction factor (e.g., Wirsching’s “rainflow correction” factor) is applied in the calculation of the short-term fatigue damage. Having calculated the short-term damage, the total fatigue damage is calculated through their weighted linear summation (using Miner’s rule). More detailed mathematical representations of the steps of the fatigue damage calculation can be found in the *ABS Guide for the Fatigue Assessment of Offshore Structures*.

The α type ESFs are obtained for details of the hull structure, where these details follow those defined for floating liquefied gas terminal hull structure in Chapter 3, Section 4.

An α of 1.0 corresponds to the unrestricted condition of a seagoing vessel. A value of α greater than 1.0 indicates a less fatigue-inducing environment than the unrestricted case.

CHAPTER 3 Structural Design Requirements

APPENDIX 4 Hull Girder Ultimate Strength

The hull girder ultimate strength calculation is based on the “gross” scantling approach, wherein the nominal design corrosion values are not considered. The hull girder ultimate bending capacity M_u for the design environmental condition (DEC) is to satisfy the limit state specified in 3-4/3.9.

The method for calculating the hull girder ultimate bending capacity M_u is to identify the critical failure modes of the main longitudinal structural elements. Structural elements compressed beyond their buckling limit have reduced strength according to their buckling and ultimate strength characteristics. All relevant failure modes for individual structural elements, such as plate buckling, beam-column buckling, torsional stiffener buckling, local buckling of stiffeners, and their interactions, are to be considered in order to identify the weakest inter-frame failure mode.

In applying the incremental-iterative approach, the following assumptions and limitations are generally to be observed:

- The ultimate strength, M_u , is calculated for the hull transverse sections between two adjacent transverse frames;
- The transverse main supporting members, including frames, girders and floors, and their associated effective plating are to have a moment of inertia not less than I_G obtained from the following equation:

$$I_G/i_o \geq 0.2(B_s/\ell)^3(B_s/s)$$

where I_G , i_o , B_s , ℓ and s are defined in 3-A2/11.5.

- The hull transverse section remains plane during each curvature increment application;
- The hull material has an elasto-plastic behavior;
- The element stress, f_i , corresponding to the element strain, ε_i , is selected as the minimum stress among the values obtained from each of the relevant load-end shortening curves, $f_i - \varepsilon_i$, in Chapter 3, Appendix 4;
- The hull transverse section is divided into a set of individual elements; the elements while considered to be acting independently are combined to provide the ultimate strength resistance of the hull's transverse cross section. These elements are:
 - Plate element, for unstiffened plates;
 - Stiffener element, consisting of a stiffener with an associated effective width of plating;

- Corner element, consisting of a plate intersection with a web plate.

The procedure for calculating the hull girder ultimate capacity, M_u , based on the incremental-iterative approach is described below.

Each step of the incremental procedure is represented by the calculation of the bending moment M^j , which acts on the hull transverse section as the effect of an imposed curvature χ^j .

For each step, the value χ^j is obtained by adding an increment of curvature, $\Delta\chi$, to the curvature χ^{j-1} value from the previous step. The increment of curvature corresponds to an increment of rotation of the hull's transverse section around its instantaneous horizontal neutral axis.

The rotation angle increment induces axial strain, ε , in each structural element of the hull section, whose value depends on the distance between the element's location and the instantaneous horizontal neutral axis. In the sagging condition, the structural elements above the instantaneous horizontal neutral axis are shortened, whereas the elements below the instantaneous horizontal neutral axis are lengthened. This is reversed in the hogging condition.

The structural element stress, f_i , induced by strain, ε_i , is to be obtained from the load-end shortening curve $f_i - \varepsilon_i$ of the element, as described in Chapter 3, Appendix 4, which takes into account the nonlinear elasto-plastic behavior of the element. The stress in each element is converted to a force. The equilibrium of the element forces is then used in an iterative process to determine the instantaneous horizontal neutral axis position of the hull's transverse cross-section.

Once the position of the instantaneous horizontal neutral axis is determined with the relevant element force distribution, the bending moment capacity of the section, M^j , about the instantaneous horizontal neutral axis, is obtained by combining the contribution from each element.

3-A4/1.3 FIGURE 1 is a flow chart showing the main steps of the incremental-iterative approach.

The nonlinear material behavior for in-plane tension or compression is different for different element types. When a structural element is in tension, full plasticity beyond yield (up to a rupture limit) is normally anticipated. However, when a structural element is under compression, elasto-plastic material and nonlinear geometric behavior occur. The tensile and compressive behavior for the different structural elements used in calculating hull girder ultimate strength can be described by the so-called, 'load-end shortening' curves, as described in detail in the following.

1 Plate Element

Unstiffened plates comprising the hull transverse sections may collapse in one of two failure modes:

- Yielding in tension
- Buckling in compression

The load-end shortening curve, $f_i - \varepsilon_i$, for unstiffened plate buckling, is shown in 3-A4/1.3 FIGURE 2 and is defined by the following equations:

1.1 Yielding in Tension

When an unstiffened plate is stretched in tension, the load-end shortening curve, $f_i - \varepsilon_i$, is idealized as the elastic-perfectly plastic relationship:

$$\frac{f_i}{f_y} = \begin{cases} \bar{\varepsilon}_i & \text{for } 0 \leq \bar{\varepsilon}_i \leq 1 \\ 1 & \text{for } \bar{\varepsilon}_i > 1 \end{cases}$$

1.3 Buckling in Compression

The stress acting on an unstiffened plate, f_i , should be limited to its ultimate strength, f_u , and not less than critical buckling stress, f_c , as specified in the following. The load-end shortening curve, $f_i - \varepsilon_i$, for unstiffened plate buckling, is defined by the following equation:

- When $\bar{\varepsilon}_i \leq f_u/f_y$

$$f_i^E = f_y \bar{\varepsilon}_i$$

- When $\bar{\varepsilon}_i > f_u/f_y$

$$\frac{f_{ip}^E}{f_y} = \begin{cases} C_E & \text{for } \alpha \geq 1 \\ C_E \cdot \frac{s}{\ell} + 0.1(1 - \frac{s}{\ell}) \left(1 + \frac{1}{\beta_E^2}\right)^2 & \text{for } \alpha < 1 \end{cases}$$

$$f_{ci}^E \leq f_{ip}^E \leq f_u$$

FIGURE 1
Flow Chart for the Evaluation of the Bending Moment-Curvature Curve, $M-\chi$

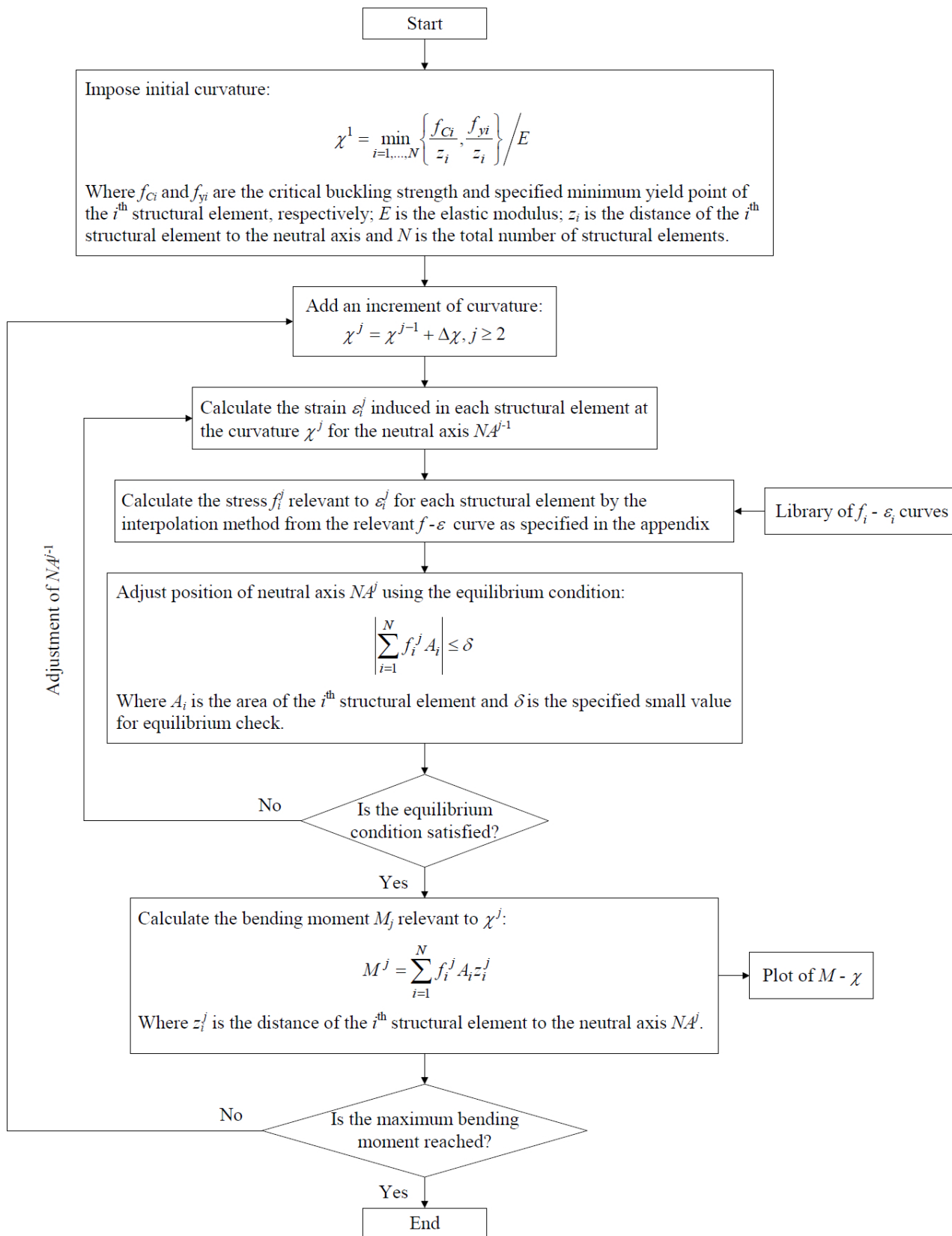

where

$$\begin{aligned}
 C_E &= 1.0 && \text{for } \beta_E \leq 1.0 \\
 &= 2/\beta_E - 1/\beta_E^2 && \text{for } \beta_E > 1.0 \\
 \beta_E &= s/t \sqrt{\bar{\varepsilon}_i^n f_y/E} \\
 f_{ci}^E &= \frac{f_{ei}}{\bar{\varepsilon}^n} && \text{for } f_e \leq P_r f_y \bar{\varepsilon}^n \\
 &= f_y \left[1 - P_r (1 - P_r) \frac{f_y \bar{\varepsilon}_i^n}{f_{ei}} \right] && \text{for } f_e > P_r f_y \bar{\varepsilon}^n \\
 \bar{\varepsilon}_i &= \text{relative strain ratio, equal to } \varepsilon_i/\varepsilon_y \\
 \varepsilon_i &= \text{element axial strain} \\
 \varepsilon_y &= \text{initial yield strain} \\
 n &= \text{exponent to } \bar{\varepsilon} \text{ denoting post-buckling behavior, which may be taken as 2.0 for steel} \\
 f_u &= \text{plate ultimate strength } \geq f_c
 \end{aligned}$$

f_c and f_u are set equal to f_{ci} and f_{ip} when $n = 0$.

FIGURE 2
Load-End Shortening Curve for Plate Element

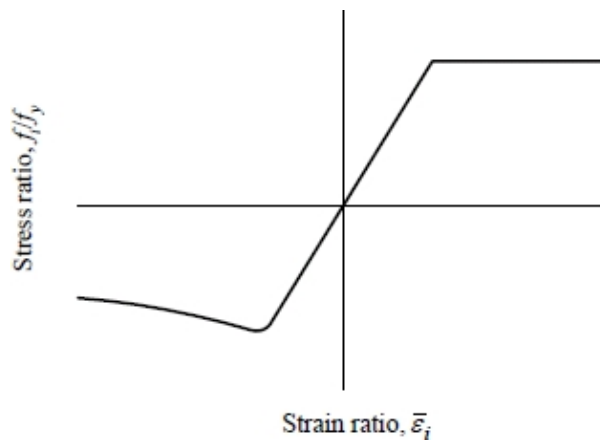

3 Stiffener Element

A longitudinal plate stiffener (i.e., axis is normal to the hull's transverse section) may fail in one of four modes:

- Yielding in tension
- Beam-column buckling
- Torsional-flexural buckling
- Local buckling of stiffeners

The load-end shortening curves, $f_i - \varepsilon_i$, for each failure mode are described below.

3.1 Yielding in Tension

The load-end shortening curve for yielding in tension is the same as in 3-A4/1.

3.3 Beam-Column Buckling

The load-end shortening curve, $f_i - \varepsilon_i$, as shown in 3-A4/Figure 3 for beam-column buckling is defined by the following equation:

- When $\bar{\varepsilon}_i \leq f_{ca}/f_y$

$$f_{ci} = f_y \bar{\varepsilon}_i$$

- When $\bar{\varepsilon}_i > f_{ca}/f_y$

$$f_{ci} = f_{ca}^E \frac{A_s + s_e^E t}{A_s + s t} \leq f_{ca} \frac{A_s + s_e t}{A_s + s t}$$

where

$$f_{ca}^E = \frac{f_{E(C)}}{\bar{\varepsilon}_i^n} \quad \text{for } f_{E(C)} \leq P_r f_y \bar{\varepsilon}_i^n$$

$$= f_y \left[1 - P_r (1 - P_r) \frac{f_y \bar{\varepsilon}_i^n}{f_{E(C)}} \right] \quad \text{for } f_{E(C)} > P_r f_y \bar{\varepsilon}_i^n$$

$$S_e^E = C_E S$$

$$C_E = 1.0 \quad \text{for } \beta_E \leq 1.0$$

$$= 2/\beta_E - 1/\beta_E^2 \quad \text{for } \beta_E > 1.0$$

f_{ca} is set equal to f_{ca}^E when $n = 0$

FIGURE 3
Load-End Shortening Curve for Beam-Column Buckling

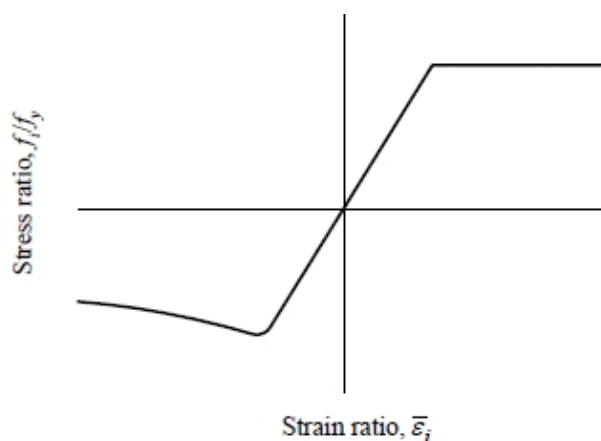

3.5 Torsional-Flexural Buckling

The load-end shortening curves, $f_i - \varepsilon_i$, as shown in 3-A4/Figure 4 for torsional-flexural buckling is defined by the following equation:

- When $\bar{\epsilon}_i \leq f_{ct}/f_y$

$$f_i = f_y \bar{\epsilon}_i$$

- When $\bar{\epsilon}_i > f_{ct}/f_y$

$$f_i = \frac{f_{ct}^E A_s + f_{ipst}^E}{A_s + st}$$

where

$$f_{ct}^E = \begin{cases} \frac{f_{ET}}{\bar{\epsilon}_i^n} & \text{for } f_{ET} \leq P_r f_y \bar{\epsilon}_i^n \\ f_y \left[1 - P_r (1 - P_r) \frac{f_y \bar{\epsilon}_i^n}{f_{ET}} \right] & \text{for } f_{ET} > P_r f_y \bar{\epsilon}_i^n \end{cases}$$

f_{ct}^E should be less than f_{ct} .

f_{ct} and f_{ET} are the critical and elastic torsional/flexural buckling stresses and are calculated in 3-A2/5.3, where gross scantlings are used.

FIGURE 4
Load-End Shortening Curve for Torsional-Flexural Buckling

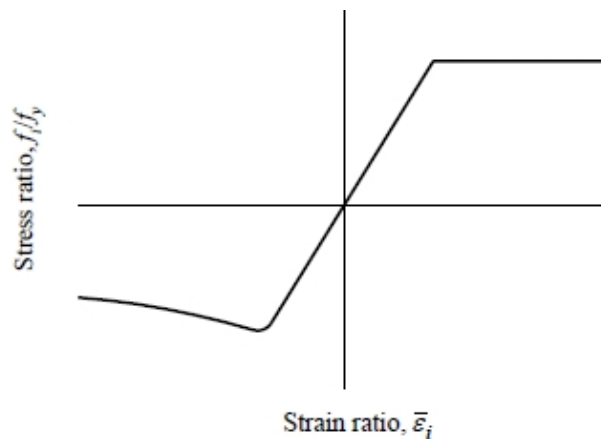

3.7 Local Buckling of Stiffeners

This failure mode should be assessed if the proportions of stiffeners specified in 3-A2/11 are not satisfied.

The load-end shortening curve, $f_i - \epsilon_p$, as shown in 3-A4/3.7 FIGURE 5 for local buckling of stiffeners is defined by the following equation:

- When $\bar{\epsilon}_i \leq f_{cl}/f_y$

$$f_i = f_y \bar{\epsilon}_i$$

- When $\bar{\epsilon}_i > f_{cl}/f_y$

$$f_i = \frac{f_{cl}^E A_s + f_{ipst}^E}{A_s + st}$$

where

$$\begin{aligned}
 f_{c\ell}^E &= \frac{f_{e\ell}}{\bar{\epsilon}^n} && \text{for } f_{e\ell} \leq P_r f_y \bar{\epsilon}^n \\
 &= f_y \left[1 - P_r (1 - P_r) \frac{f_y \bar{\epsilon}_i^n}{f_{e\ell}} \right] && \text{for } f_{e\ell} > P_r f_y \bar{\epsilon}^n
 \end{aligned}$$

$f_{c\ell}^E$ should be less than $f_{c\ell}$.

$f_{c\ell}$ and $f_{e\ell}$ are local critical and elastic buckling stress and are calculated in 3-A2/3, where gross scantlings are used.

FIGURE 5
Load-End Shortening Curve for Local Buckling

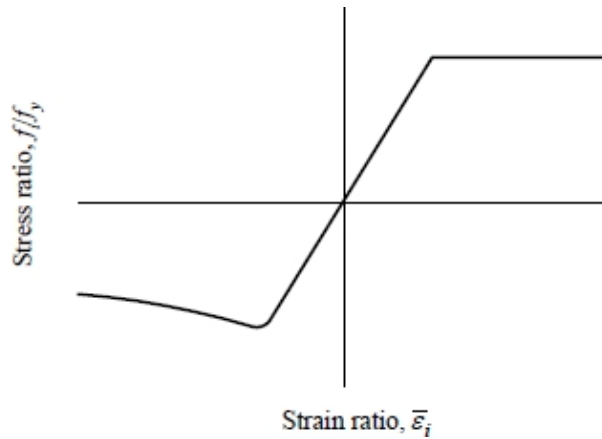

5 Corner Element

Corner elements are considered stocky elements, which collapse due to ‘fully plastic’ development. The relevant load-end shortening curve, $f_i - \epsilon_i$, as shown in 3-A4/5 FIGURE 6, is idealized by the elastic-perfectly plastic relationship given in the following:

$$\frac{f_i}{f_y} = \begin{cases} -1 & \text{for } \bar{\epsilon}_i < -1 \\ \bar{\epsilon}_i & \text{for } -1 \leq \bar{\epsilon}_i \leq 1 \\ 1 & \text{for } \bar{\epsilon}_i > 1 \end{cases}$$

FIGURE 6
Load-End Shortening Curve for a Corner Element

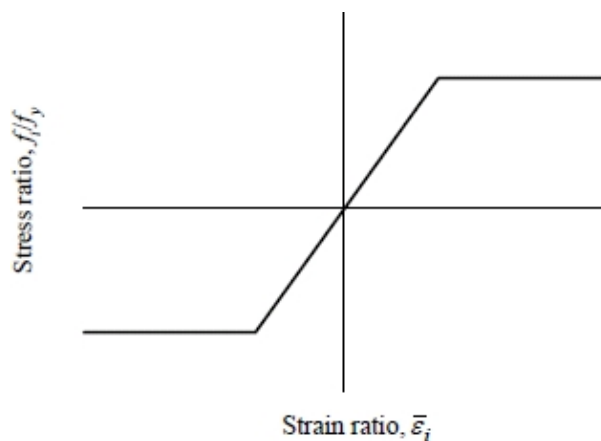

CHAPTER 3 Structural Design Requirements

APPENDIX 5 Hull Structural Modeling and Analysis

1 Objective

This Appendix provides guidance for the calculation of structural responses by performing finite element analysis of the floating terminal structure, as required by the Total Strength Assessment (TSA) in Chapter 3, Section 5.

In general, this guidance is based on the requirements for a three cargo tank length model as outlined in 3-5/9. With this Appendix, it is intended that the structural idealization, load application, and analysis procedure used for the finite element structural analysis are performed in a consistent manner and based on sound engineering judgment.

3 Scope of Application

The strength requirements specified in Chapter 3, Appendix 5 for the hull structure are based on a “net” scantling approach as defined in 3-2/3. For new construction, the nominal design corrosion margins, given in 3-2/3.1 TABLE 1 and 3-2/Figures 1A and 1B for floating terminals with single center cargo tank or two cargo tanks abreast arrangements, respectively, are to be deducted from the scantlings for the finite element analysis and strength assessment of the hull structure. For floating terminals with independent tanks, the strength requirements of the independent tanks are based on gross or as-built scantlings. Owner’s extra scantlings as included in the floating terminal’s design specification are not to be used in the structural models for analysis.

The analysis of floating terminals with membrane tank containment system includes a three-dimensional global model of the three-hold hull structure and local fine-mesh models as follows:

- Transverse web frames, longitudinal girders, horizontal girders, side stringers, and centerline ring frames, etc.

The analysis of floating terminals with independent tank containment system includes a three-dimensional global model of the three-hold hull girder and the independent tanks. Local fine-mesh models include:

- Main supporting members of hull and cargo tanks structures
- Cargo tank supports and chocks as well as associated seatings in hull and cargo tank structures

Local fine-mesh models are used to determine the additional requirement for critical areas in the hull and tank structures.

5 Extent of the 3-D Global Finite Element Model

The purpose of the 3-D global FE analysis is to determine the overall structural response of the hull structure, including primary and secondary bending, and also to obtain appropriate boundary conditions for use in the local fine-mesh FE analysis of local structures. The extent of the hull structure to be modeled is to cover three cargo tank lengths located at about amidships, as shown in 3-A5/5 FIGURE 1. It is to extend two frames fore and aft of the two end bulkheads. All primary load-carrying members are to be modeled. Secondary structural members which may affect the overall load distribution should also be appropriately accounted for.

FIGURE 1
Extent of 3-D Global Finite Element Model

Hull Structure and Independent Prismatic Tank
(shows only starboard side of the full breadth model)

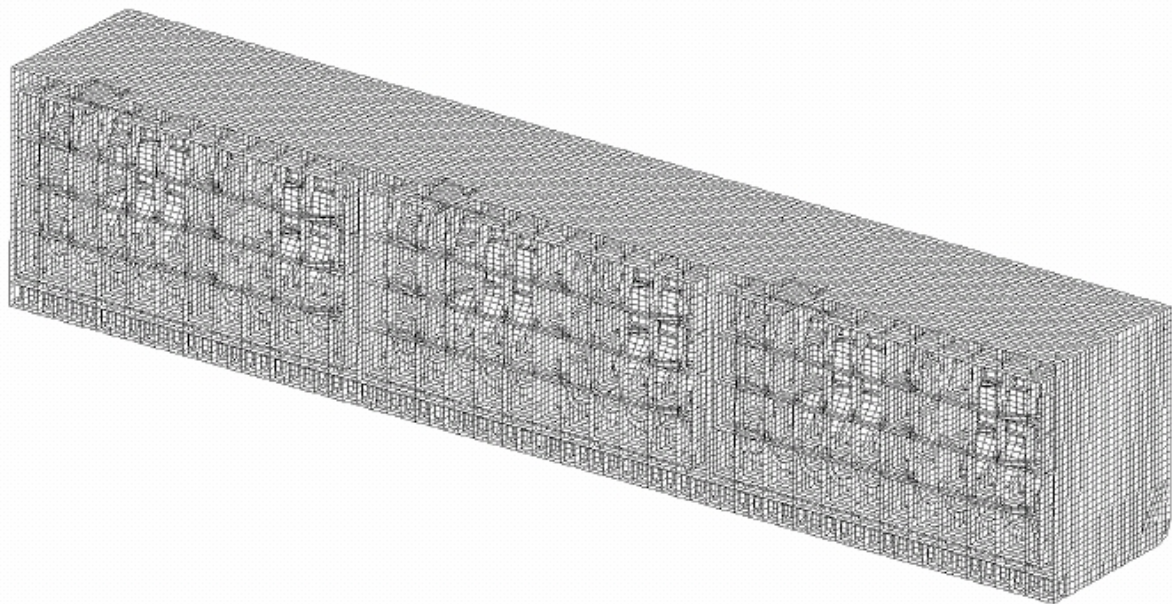

7 Coordinate System of the Model

The global coordinate (right-hand) system of this reference finite element model is defined as follows:

- X axis: Longitudinal direction, positive forward,
- Y axis: Vertical direction, positive upwards from baseline,
- Z axis: Transverse direction, positive toward starboard from centerline,
- Origin: At the intersection of baseline and centerline at first watertight bulkhead of the aft end of the model

The six degrees of freedom for the nodes are defined with respect to the Cartesian global X, Y and Z axes of the 3-D finite element model, as u_x , u_y , and u_z for the three translational degrees of freedom, and θ_x , θ_y , and θ_z for the three rotational degrees of freedom.

9 Element Types

The structural elements, whose geometry, configuration and stiffness approximate the actual ship's hull structure, are of three types commonly used.

- i) Rod (or truss) elements*, with axial stiffness only and constant cross-sectional area along the length of the element.
- ii) Bar (or Beam) elements without offset*, with axial, torsional and bi-directional shear and bending stiffness and with constant properties along the length of the element.
- iii) Shell (or bending plate) elements*, with in-plane stiffness and out-of-plane bending stiffness with constant thickness.

Higher order element types exist, however the above three *simple* types of element are sufficient for a good representation of the hull girder. The appropriate usage of the aforementioned element types in the modeling procedure is discussed in the following sections.

9.1 Plate Elements

For finite element modeling of a hull structure, the plating is typically represented by bending plate elements.

In general, the plate element mesh is to follow the stiffener system as far as practicable, hence representing the actual plate panels between stiffeners. The mesh size is to satisfy the following requirements:

- i)* One element between every longitudinal stiffeners, see 3-A5/9.1 FIGURE 2. Longitudinally, the element length is not to be greater than 2 longitudinal spaces.
- ii)* One element between every vertical stiffener on transverse bulkheads, see 3-A5/9.1 FIGURE 3.
- iii)* One element between every web stiffener on transverse and vertical web frames and stringers, see 3-A5/9.1 FIGURE 2.
- iv)* At least three elements over the depth of double bottom girders and floors, transverse web frames, vertical web frames and horizontal stringers on transverse bulkheads.
- v)* For deck transverse and horizontal stringers on transverse bulkheads and longitudinal bulkheads with a smaller web depth, representation using two elements over the depth is acceptable provided that there is at least one element between every web stiffener. The mesh size of the adjacent structure is to be adjusted to suit.
- vi)* The mesh on the hopper tank web frame shall be fine enough to represent the shape of the web ring opening, see 3-A5/9.1 FIGURE 2.
- vii)* The curvature of the free edge on large brackets of primary supporting members is to be modeled accurately to avoid unrealistic high stress due to geometry discontinuities. In general, a mesh size equal to the stiffener spacing is acceptable.
- viii)* The bracket toe may be terminated at the nearest nodal point provided that the modeled length of bracket arm does not exceed the actual bracket arm length.
- ix)* The bracket flange is not to be connected to the plating, see 3-A5/9.1 FIGURE 4. An acceptable mesh is shown in 3-A5/9.1 FIGURE 4. A finer mesh is to be used for the determination of detailed stress at the bracket toe, see 3-A5/11.5.1 FIGURE 6.
- x)* The aspect ratio of the plate elements is in general not to exceed three. The use of triangular plate elements is to be kept to a minimum. Where possible, the aspect ratio of plate elements in areas where there are likely to be high stresses or a high stress gradient is to be kept close to one and the use of triangular elements is to be avoided.

Manholes on transverse and longitudinal structures, such as double bottom floors and longitudinal girders, are generally ignored in the global model. Leaving out plate elements or reducing plate thicknesses to account for such manholes in the 3-D model are not advisable, because this would sometimes result in unrealistic shearing stresses for the thinned plates or the adjacent elements. The actual behavior of a round or elliptical manhole with or without a flange is quite different from the modeled thin plate or element opening which is usually rectangular.

FIGURE 2
Typical Finite Element Mesh on Web Frame

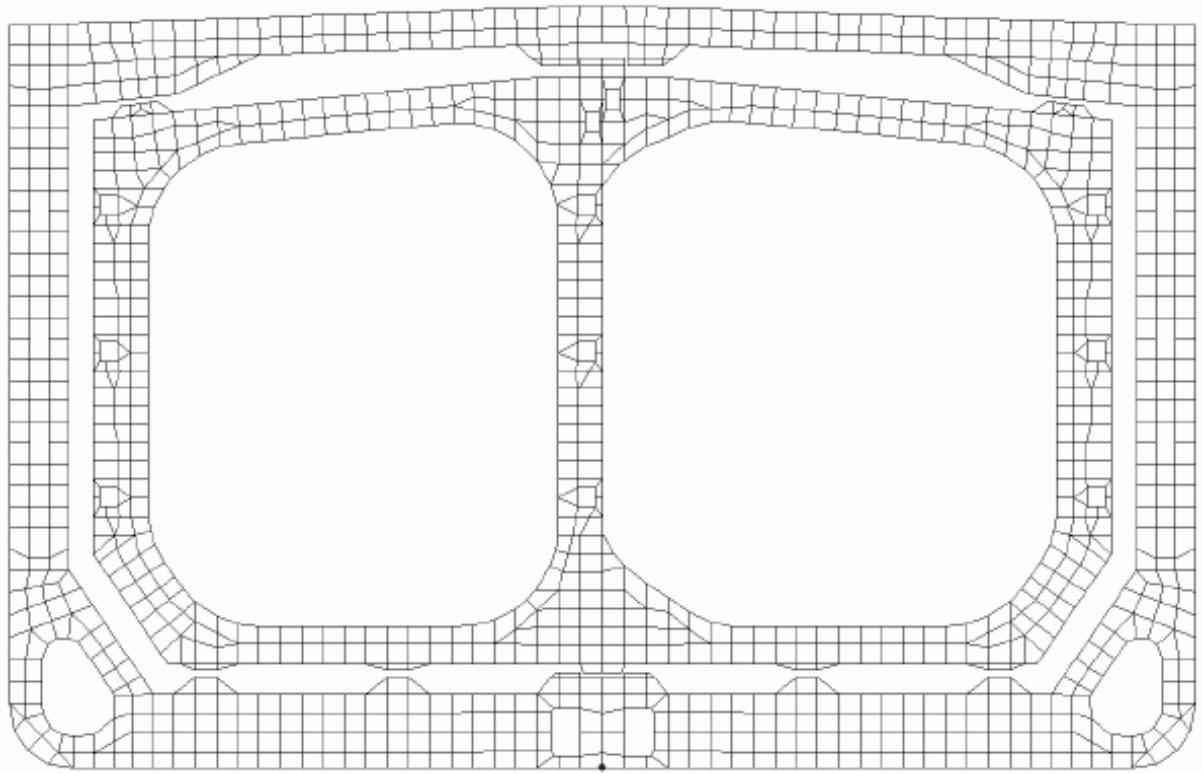

FIGURE 3
Typical Finite Element Mesh on Transverse Bulkhead

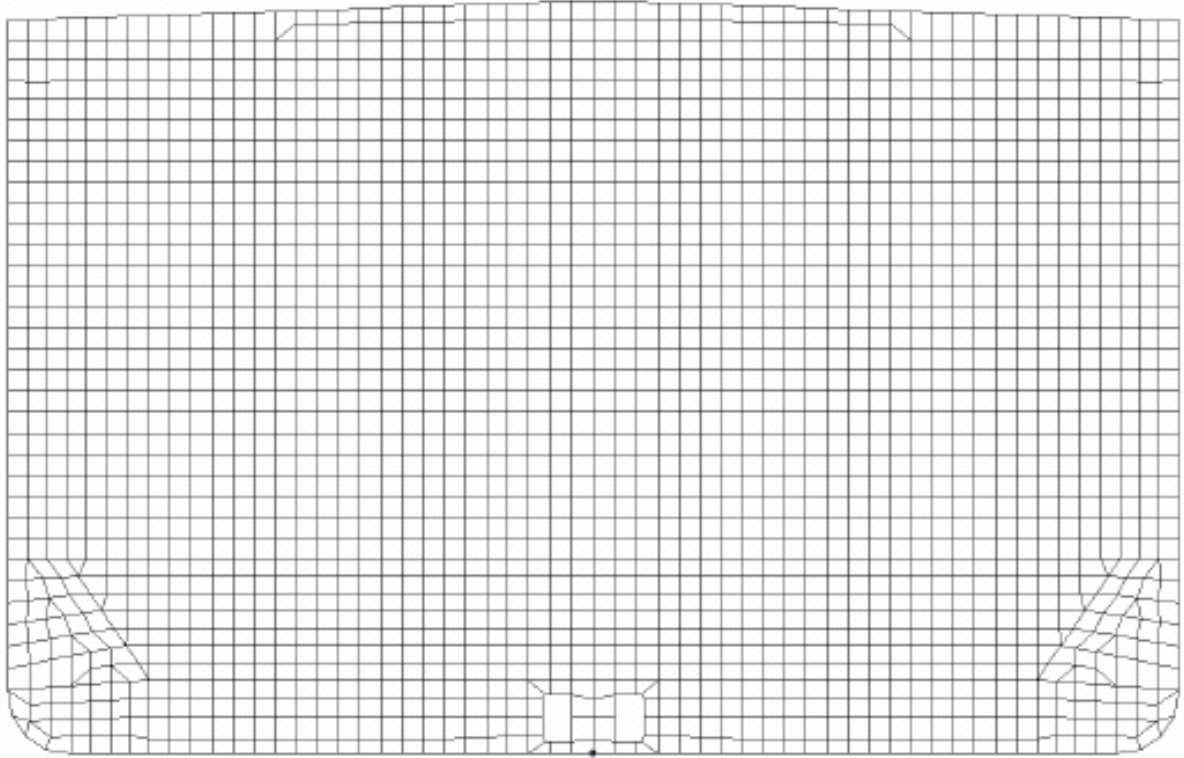
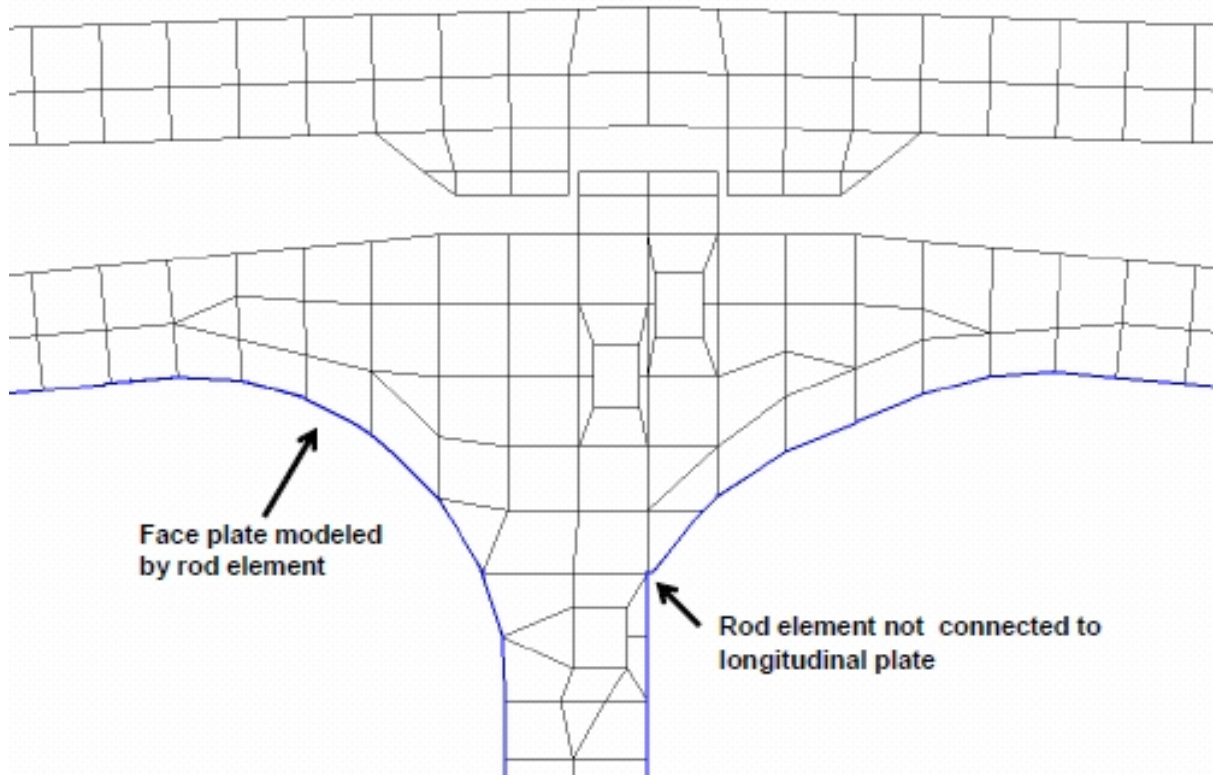

FIGURE 4
Typical Finite Element Mesh on Transverse Web Frame Main Bracket



9.3 Bar (or Beam) Elements for Stiffeners

All local stiffeners are to be modeled. The stiffeners may be modeled using line elements positioned in the plane of the plating. Bar elements are to be used in areas under action of lateral loads whilst rod elements in 3-A5/9.5 may be used to represent local stiffeners on internal structural members under no lateral loads.

The bar elements are to have the following properties:

- i)* Stiffeners are typically modeled by bar elements without offset.
- ii)* The bar element cross sectional area is based on the net stiffener area excluding the area of the attached plating.
- iii)* Out of plane bending properties are to represent the inertia of the combined plating and stiffener.
- iv)* The width of the attached plate is to be taken as half + half stiffener spacing on each side of the stiffener.
- v)* The eccentricity of the neutral axis is not required to be modeled.

9.5 Rod (or Truss) Elements for Stiffeners

Web stiffeners on primary support members are to be modeled. Where these stiffeners are not in line with the primary FE mesh, it is sufficient to place the line element along the nearby nodal points provided that the adjusted distance does not exceed 0.2 times the stiffener spacing under consideration. The stresses and buckling utilization factors obtained need not be corrected for the adjustment. Buckling stiffeners on large brackets, deck transverse and stringers parallel to the flange are to be modeled. These stiffeners may be modeled using rod elements.

9.7 Rod Elements for Face Plates of Primary Supporting Members (1 September 2012)

All face plates should be accounted for and can be modeled by rod elements.

For a typical hull structure, there are numerous secondary flat bars, stiffeners, tripping brackets and panel “breakers”. These structural members are mainly to provide local stiffness to plate panels against buckling or vibration. These secondary stiffening members generally need not be included in the global model as their influence on the overall response of the hull structure is negligible.

11 3-D Global FE Modeling

11.1 Modeling of Hull and Cargo Tank Structures

A 3-D global finite element model is used to obtain the overall response of the hull girder under the imposed sea loading. The stress results of the global model are used not only to assess the hull girder plating of the deck(s), side shell, bottom, inner bottom, longitudinal bulkheads, transverse bulkheads and cofferdam bulkheads but also to assess the main supporting members. In addition for independent cargo tank containment systems the cargo tank structure and the interaction between the hull structure and cargo tanks through chocks and other supports must be assessed. The boundary conditions for the local FE models are the appropriate nodal displacements obtained from the 3-D global model analysis. In developing the 3-D global finite element model, special attention should be paid to the following general guidance:

- i)* The finite element model should include all primary load-carrying members. Secondary structural members which may affect the overall load distribution should also be appropriately accounted for.
- ii)* Structural idealization should be based on the stiffness and anticipated response of the structure, not wholly on the geometry of the structure itself.
- iii)* A common mistake is to simply match the finite element mesh with the configuration of the structure. Very often a finite element model, created in this way, may “look good” and represent

the structural geometry well, but in reality it represents the structural properties and performance poorly.

- iv) It is desirable to have consistent modeling throughout the entire length of the three cargo tanks considered. However, the middle tank should always have the desired mesh, where more accurate results are expected (due to boundary effects) and are therefore used in the strength assessment. If approximations have to be made, do so only in the two end-tanks.
- v) It is important to consider the relative stiffness between associated structural members and their anticipated response under the specified loading.
- vi) Double bottom floors have high restraint at the ends, and therefore require an adequate mesh to achieve reasonable accuracy.

11.3 Modeling of Supports and Chocks

Hull and independent cargo tank structures usually interact through the following supports and chocks which may be represented using rod elements, see 3-A5/11.3 FIGURE 5

- Vertical cargo tank supports,
- Anti-roll chocks,
- Anti-pitch (or collision) chocks,
- Anti-flotation chocks.

These rod elements are intended to represent the overall structural response of the aforementioned supports and chocks. The axial stiffness of each support (or chock) is to be determined from the properties of the layers of special materials such as plywood, resin and adhesive as well as the seatings mounted on the hull and cargo tank structures.

As independent cargo tank supports and chocks do not physically carry any tensional forces, the final results for some standard load cases are to be obtained by progressively removing those rod elements that are in tension. In some cases, it may take several iterations to reach the final force equilibrium.

For anti-pitch and anti-roll chocks, there are two contact surfaces on each side of the male key. Rod elements may be introduced to each surface. Those rod elements in tension are to be removed from the subsequent analysis.

The interaction between hull and independent cargo tank structures in way of supports and chocks may be represented using gap elements or non-linear rod elements with zero stiffness when under tensions.

FIGURE 5
Global Finite Element Model of Hull and Tank Structure (Main Supporting Members, Supports and Chocks)

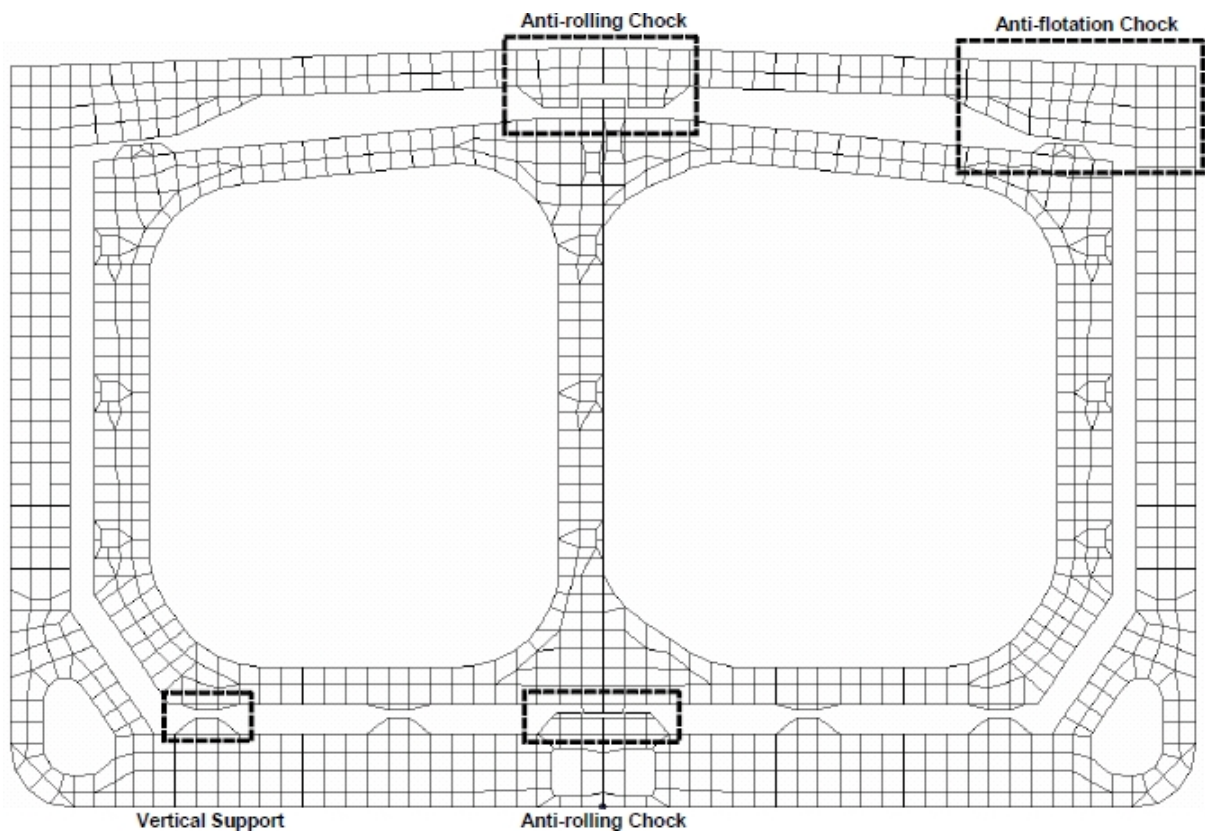

11.5 Finite Element Modeling for Critical Structural Areas

11.5.1 General

In order to have critical structural areas modeled with the desired accuracy, the mesh size is to be finer than the recommended basic mesh size for global finite element models. For access openings in way of suspected high stress areas, bracket connections, supports and chocks, element sizes of $1/5 \sim 1/10$ longitudinal spacing may be required. Element sizes finer than $1/10$ longitudinal spacing are not recommended unless the stress concentration factor (SCF) at a structural detail is to be established. Any transition from relatively coarse mesh to finer mesh is to be smooth and gradual.

3-A5/11.5.1 FIGURE 6 below shows one acceptable meshing arrangement for a bracket toe for calculating the field or local stress. It is generally not recommended to have the rod or bar element at the tip of the bracket toe directly connected to the attached plating. If the field stress is found approaching the stress limit, a finer mesh model of the bracket may need to be further evaluated.

Materials such as plywood, resin and adhesive are normally fitted to the contacting surfaces of supports or chocks for the purpose of leveling or alignment. The strength of these materials under compressive or frictional contact forces is to be verified in accordance with the requirements in 3-5/3.11

The seatings for supports and chocks are to be verified using fine mesh finite element models. Among the supports (or chocks) of the same configuration, a fine mesh finite element model is to be constructed for the one that is subject to the largest contact force.

For each critical structural area, the fine mesh finite element model is to be sufficiently extended to relatively stiff main structural members where the boundary displacements can be properly defined from the global finite element model. Consideration is to be given to the boundary effects on stress distribution in way of the critical structural area.

FIGURE 6
Modeling of Bracket Toe and Tapered Face Plate

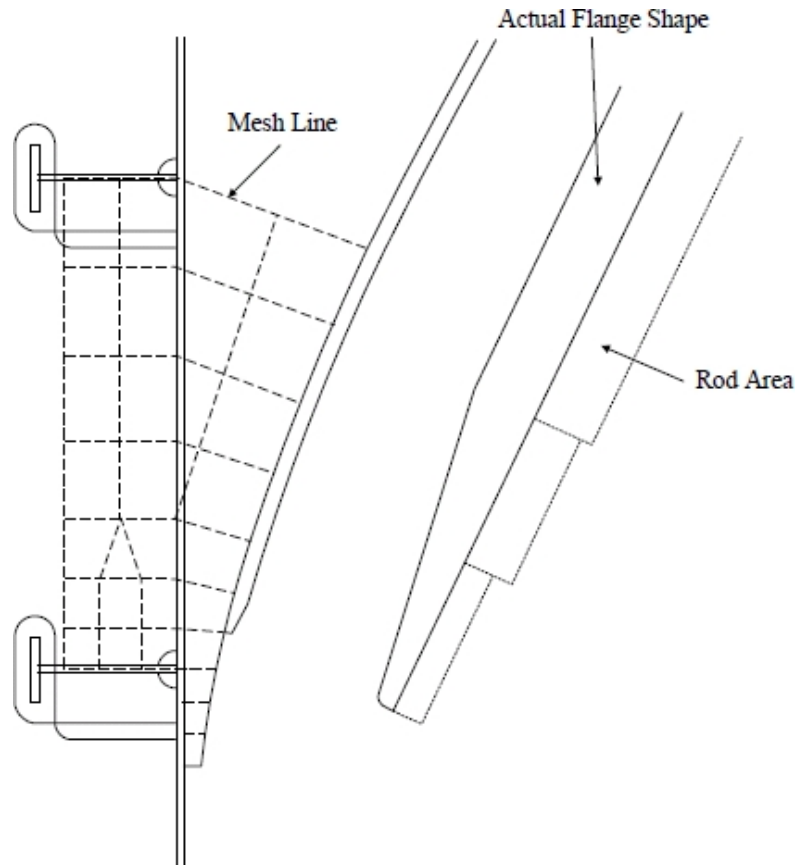

11.5.2 Critical Structural Areas

Critical structural areas are to be identified from a global finite element model and service experience and evaluated using fine mesh finite element models. Upon completion of the global finite element analysis, the following structural areas are to be screened for high stresses. The final list of critical structural areas selected for fine mesh finite element analysis is to be confirmed by ABS.

Hull Structure (See 3-A5/11.5.2 FIGURE 7)

- Dome opening
- Lower and upper brackets of side frame
- Access openings in double bottom floors and girders
- Vertical stiffeners of transverse bulkheads
- Brackets connecting transverse bulkhead vertical stiffeners and deck longitudinals
- Lower brackets of transverse bulkheads

Cargo Tank Structure (See 3-A5/11.5.2 FIGURE 7)

- Bracket connections of transverse web frames
- Bracket connections of swash bulkheads
- Bracket connections of horizontal stringers

Seatings for Cargo Tank Supports and Chocks

- Each type of vertical supports
- Each type of anti-roll chocks
- Each type of anti-pitch chocks
- Each type of anti-flotation chocks

When a relatively flexible structural member is connected to a very stiff main supporting member, the connection bracket is to be evaluated using a fine mesh finite element model. Additional critical areas may be selected for novel structural arrangements and connection details.

FIGURE 7
Critical Areas of Hull and Cargo Tank Structures

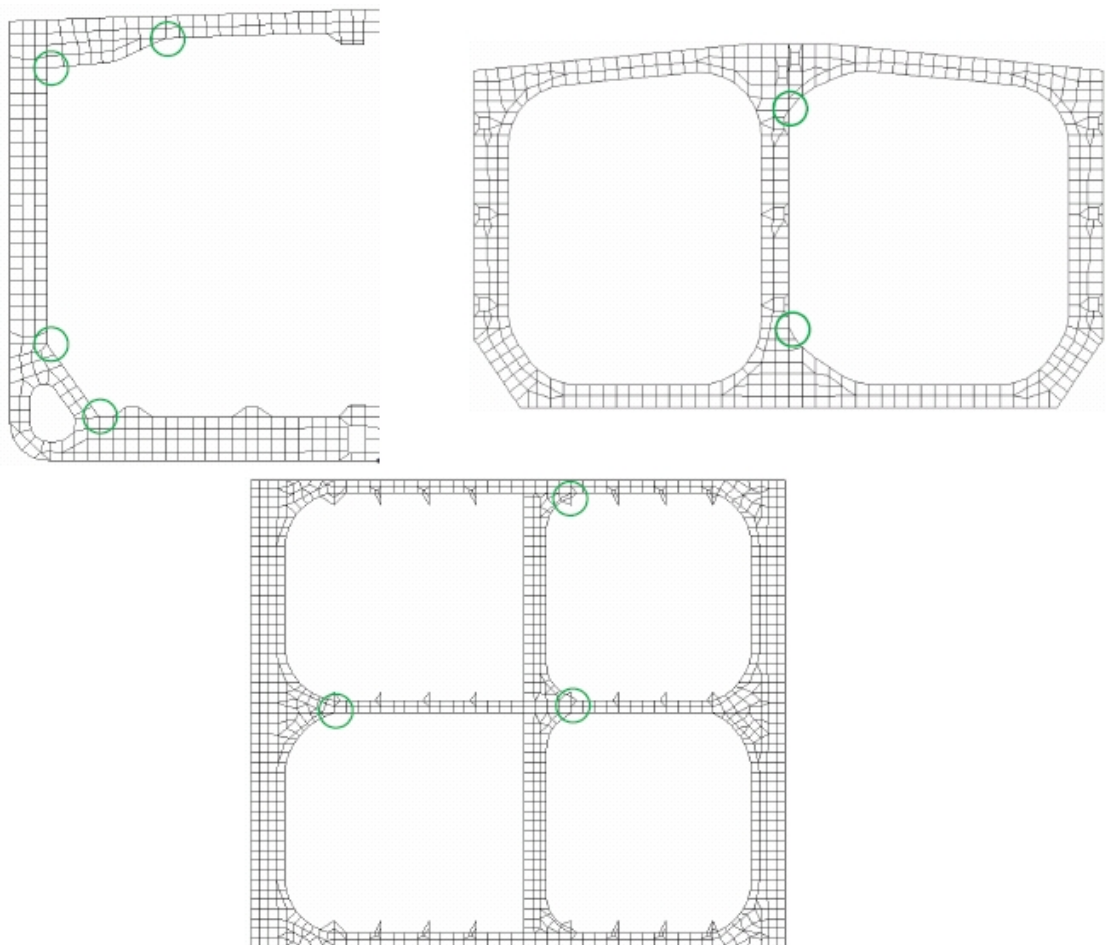

11.5.3 Seatings for Vertical Supports

For each type of vertical supports, two separate fine mesh finite element models are to be analyzed, representing the seatings fitted to the hull and cargo tank structures, respectively. 3-A5/11.5.3 FIGURE 8 shows the two fine mesh models for the most outboard vertical support.

For the seatings fitted to the hull structure, the fine mesh model is to extend, in the longitudinal direction, forward and aft of the vertical support by one floor spacing. In the transverse direction, the model is to terminate at either side girders or other main support members. In the vertical direction, the full depth of the bottom structure including the seatings is to be modeled.

For the seatings fitted to the cargo tank structure, the fine mesh model is to extend, in the longitudinal and transverse directions, in the same way as described above. Vertically, the model is to cover from the bottom plating of the cargo tank including the seatings to the adjacent horizontal stringer.

FIGURE 8
Mesh Arrangement for Critical Structural Areas (Vertical Support)

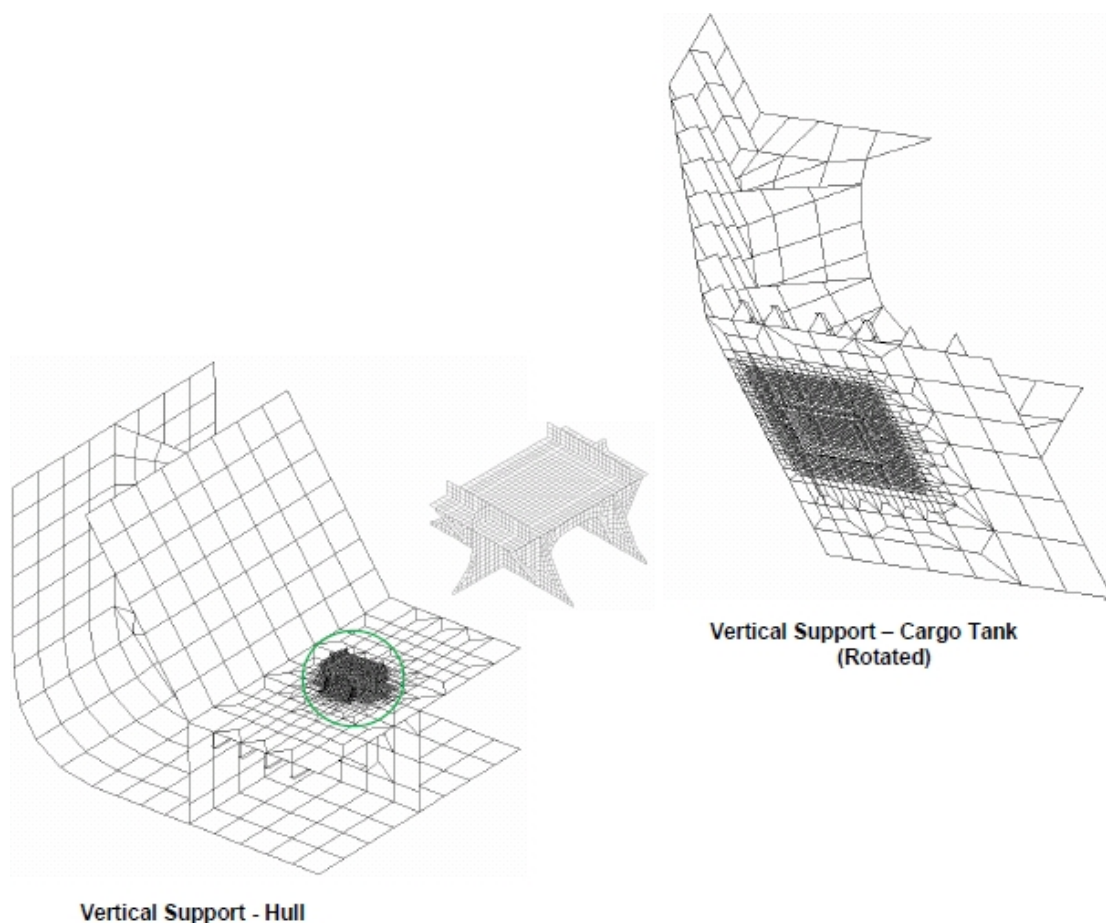

11.5.4 Seatings for Anti-Roll Chocks

For each type of anti-roll chocks, two separate fine mesh finite element models are to be analyzed, representing the seatings fitted to the hull and cargo tank structures, respectively.

3-A5/11.5.4 FIGURE 9 shows the two fine mesh models for an anti-roll chock at the deck level.

For the seatings fitted to the hull structure, the fine mesh model is to extend, in the longitudinal direction, forward and aft of the chock by one transverse web frame spacing. In the transverse direction, the model is to terminate at either side girders or other stiff main support members.

For the seatings fitted to the cargo tank structure, the fine mesh model is to extend, in the longitudinal and transverse directions, in the same way as described above. Vertically, the model is to cover from the top plating of the cargo tank including the seatings to the adjacent horizontal stringer.

FIGURE 9
Mesh Arrangement for Critical Structural Areas (Anti-Rolling Chock)

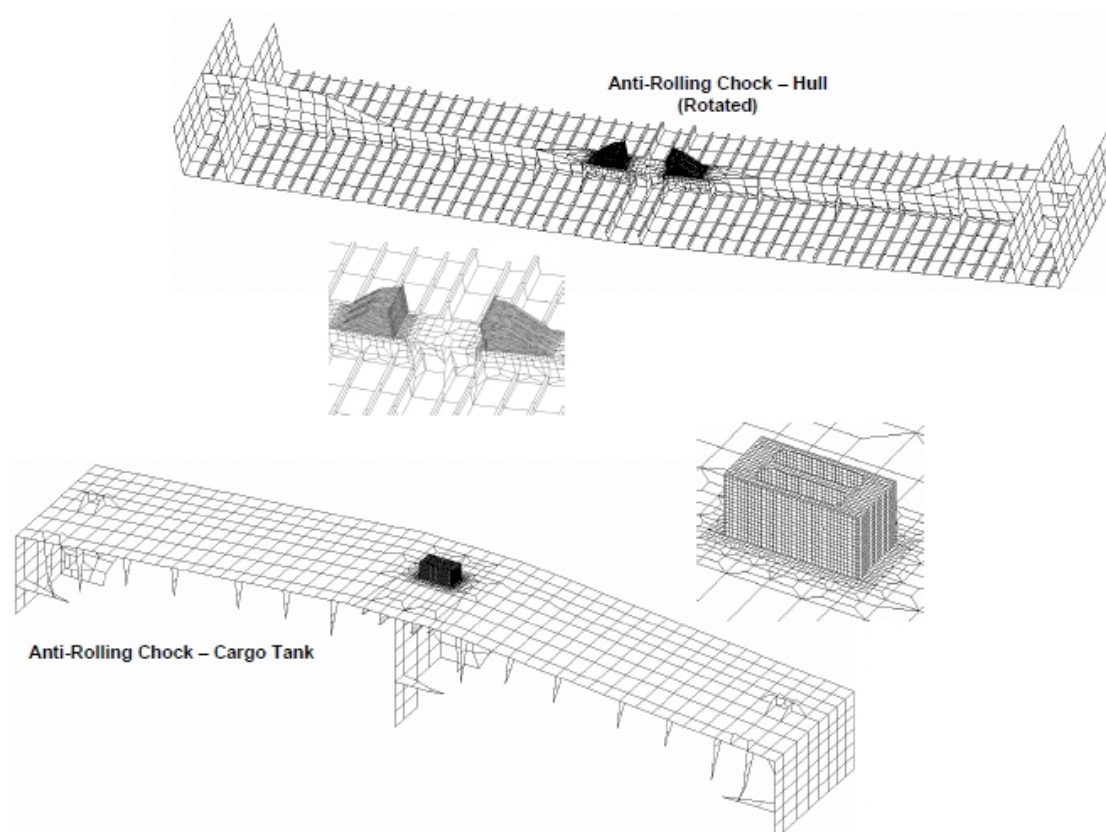

11.5.5 Seatings for Anti-Pitch Chocks

For each type of anti-pitch chocks, two separate fine mesh finite element models are to be analyzed, representing the seatings fitted to the hull and cargo tank structures, respectively.

3-A5/11.5.5 FIGURE 10 shows the two fine mesh models for an anti-pitch chock at the bottom level.

For the seatings fitted to the hull structure, the fine mesh model is to extend, in the longitudinal direction, forward and aft of the chock by one floor spacing. In the transverse direction, the model is to terminate at either side girders or other main support members. In the vertical direction, the full depth of the double bottom is to be modeled. For the seatings fitted to the cargo tank structure, the fine mesh model is to extend, in the longitudinal and transverse directions, in the same way as described above. Vertically, the model is to extend from one main support members to another main support member.

FIGURE 10
Mesh Arrangement for Critical Structural Areas (Anti-Pitching Chock)

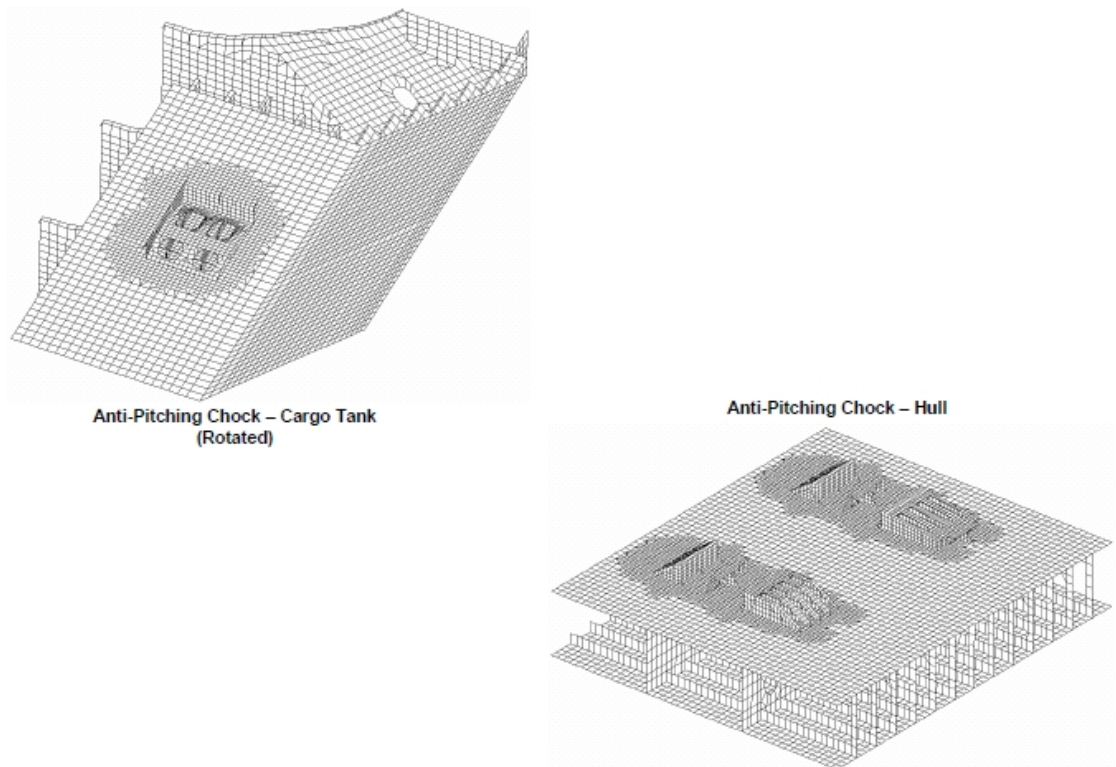

11.5.6 Seatings for Anti-Floatation Chocks

For each type of anti-floatation chocks, two separate fine mesh finite element models are to be analyzed. Typically, the seatings are fitted to the cargo tank structure.

3-A5/11.5.6 FIGURE 11 shows the two fine mesh models for an anti-floatation chock. For the seatings fitted to the cargo tank structure, the fine mesh model is to extend, in the longitudinal direction, forward and aft of the anti-floatation chock by one web spacing. For the seatings fitted to the hull structure, the fine mesh model is to extend, in the longitudinal direction, forward and aft of the chock by one web spacing.

FIGURE 11
Mesh Arrangement for Critical Structural Areas (Anti-Flotation Chock)

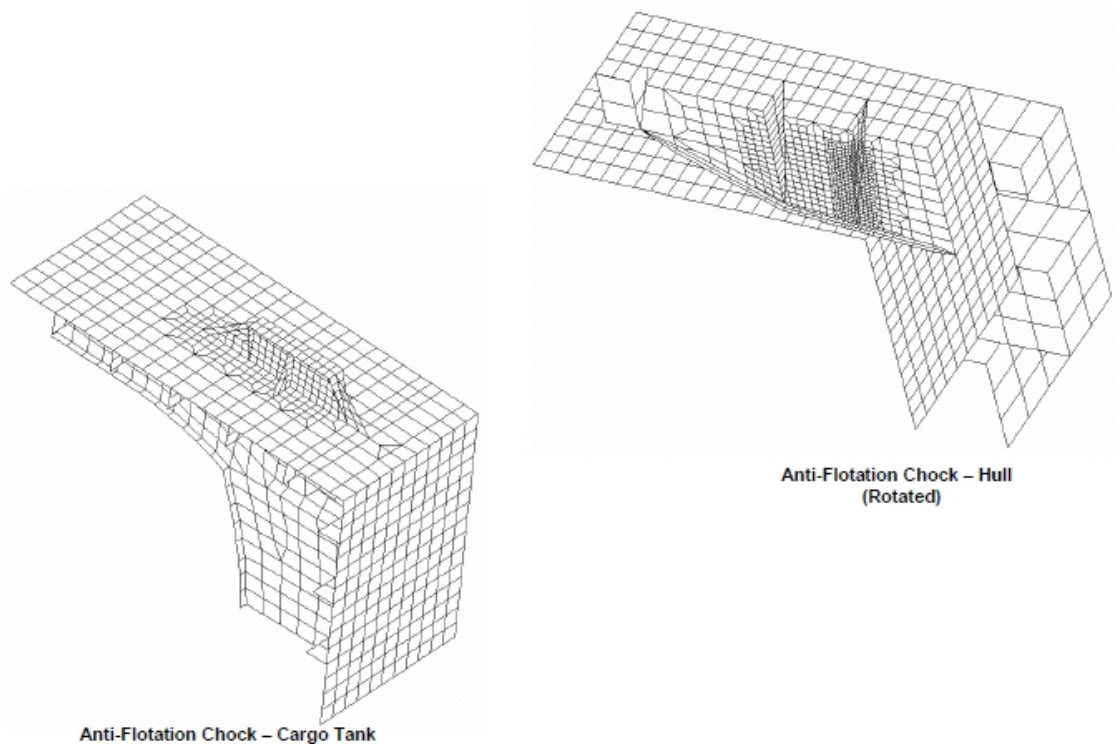

11.7 Finite Element Modeling for Critical Structural Details

Complex structural details that are prone to cracking are to be evaluated in accordance with the fatigue strength requirements in 3-5/7. For the purpose of fatigue strength verification, hot spot stresses are to be calculated assuming an idealized structural detail with no misalignment. Fine mesh finite element models are to be constructed with a mesh size approximately close to $t \times t$ in way of the target critical detail; the meshing arrangement away from the critical area may be progressively coarser. Quadrilateral elements of good proportion are generally to be used to model the hot spot. 3-A5/11.7 FIGURE 12 shows the fine mesh finite element model for the deck longitudinal connection in way of an anti-roll chock.

FIGURE 12 Fine Mesh Finite Element Analysis for Fatigue Strength Evaluation

(Example of Deck Longitudinal Connection in Way of Anti-Roll Chock)

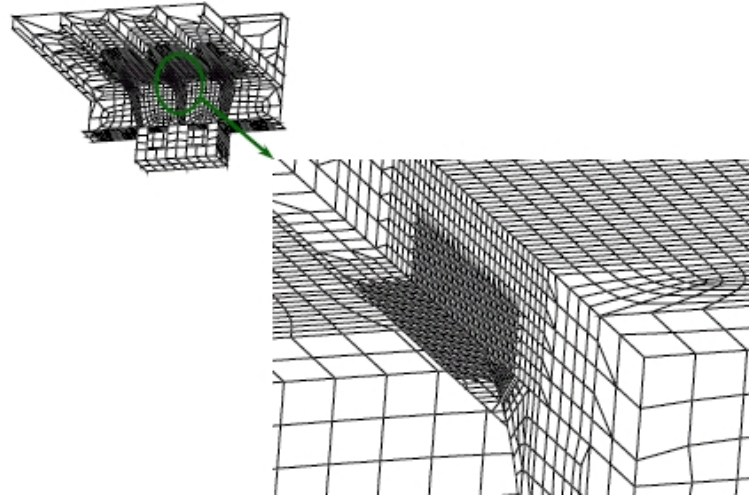

Critical structural details are to be identified from a global finite element model, local fine mesh models, and service experience. Upon completion of the global and local finite element evaluations, the fatigue-prone details in the following structural areas are to be screened for high stress ranges. The final list of critical structural details selected for fatigue strength evaluation is to be confirmed by ABS.

Hull Structure:

- Hatch corners of dome openings
- Lower and upper bracket toes of side frames
- Bracket connections of transverse bulkhead vertical stiffeners at inner bottom and deck levels
- Bracket connections of inner bottom longitudinal in way of vertical supports, anti-roll and anti-pitch chocks
- Bracket connections of side longitudinal close to the ballast waterline
- Bracket toes of deck transverse stiffeners
- Hopper corner connection in way of transverse web frame (mid-tank)

Cargo Tank Structure

- Bracket toes of transverse web frames
- Bracket toes of swash bulkheads
- Bracket toes of horizontal stringers

Seatings for Cargo Tank Supports and Chocks

- Bracket toes of each type of vertical support
- Bracket toes of each type of anti-roll chock
- Bracket toes of each type of anti-pitch chock

13 Loading Conditions

13.1 Combined Load Cases and Loading Pattern

The standard combined load cases as specified in 3-3/Tables 1A through 1C with the corresponding loading pattern specified in 3-3/Figure 1 are to be used in the FE analysis.

13.3 Sloshing Load Cases

In assessing the strength of tank boundary supporting structures, the two combined load cases as specified in 3-3/Table 2 with the corresponding loading pattern specified in 3-3/Figure 16 are to be considered in the FE analysis.

13.5 Target Hull Girder Vertical Bending Moment and Vertical Shear Force (1 September 2012)

13.5.1 Hull Girder Vertical Bending Moment

The hull girder vertical bending moment is to reach the following required target value, M_{targ} , which is a combination of the Rule-required still water bending moment and the wave-induced vertical bending moment, at a section within the length of the middle tank of the three tanks FE model:

$$M_{targ} = M_{sw} + k_u k_c \beta_{VBM} M_w$$

where

- M_{sw} = still water bending moment to be applied to the FE load case, as specified in 3-3/3 for either hogging or sagging conditions
- k_u = load factor is taken as 1.0 as specified in 3-3/Tables 1A through 1D and 3-3/Table 3
- k_c = correlation factor is taken value as specified in 3-3/Tables 1A through 1D and 3-3/Table 3
- β_{VBM} = ESF for vertical bending moments as defined in 3-A3/3
- M_w = vertical wave bending moment for the dynamic load case under consideration, calculated in accordance with 3-3/5.1.1 for either hogging or sagging conditions

13.5.2 Hull Girder Vertical Shear Force

The hull girder vertical shear force is to reach the following required target value, F_{targ} at the forward transverse bulkhead position of the middle tank. The target hull girder vertical shear force is a combination of the Rule-required still water shear force and the wave-induced vertical shear force:

$$F_{targ} = F_{sw} + k_u k_c \beta_{VSF} F_w$$

where

- F_{sw} = vertical still water shear force to be applied to the FE load case, as specified in 3-3/3 for either positive or negative shears
- k_u = load factor is taken as 1.0 as specified in 3-3/Tables 1A through 1D and 3-3/Table 3
- k_c = correlation factor is taken value as specified in 3-3/Tables 1A through 1D and 3-3/Table 3
- β_{VSF} = ESF for vertical shear force as defined in 3-A3/3
- F_w = vertical wave shear force for the dynamic load case under consideration, calculated in accordance with 3-3/5.1.3 for either positive or negative shears

The required hull girder vertical bending moment and shear force are to be achieved in the same load case where required by 3-3/Tables 1A through 1C and 3-3/Table 3. The procedure to apply the required shear force and bending moment distributions is described in 3-A5/15.

13.7 Target Hull Girder Horizontal Wave Bending Moment (1 September 2012)

The hull girder horizontal wave bending moment at a section within the length of the middle tank of the three tanks FE model is to reach the target value required by the dynamic load case as required by 3-3/Tables 1A through 1C and 3-3/Table 3, calculated in accordance with 3-3/7.3.2.

The procedure to adjust the required hull girder horizontal bending moment is described in 3-A5/15.

15 Procedure to Adjust Hull Girder Shear Force and Bending Moment

15.1 General (1 September 2012)

The procedure described in this Subsection is to be applied to adjust the hull girder horizontal bending moment, vertical shear force and vertical bending moment distributions on the three cargo tanks FE model to achieve the required target values.

Vertical distributed loads are applied to each frame position, together with a vertical bending moment applied to the model ends to produce the required value of vertical shear force at the forward bulkhead of the middle tank of the FE model, and the required value of vertical bending moment at a section within the length of the middle tank of the FE model. The required values are specified in 3-A5/13.5.

A horizontal bending moment is applied to the ends of the model to produce the required target value of horizontal bending moment at a section within the length of the middle tank of the FE model. The required values are specified in 3-A5/13.7.

15.3 Shear Force and Bending Moment due to Local Loads

15.3.1 Vertical Shear Forces

The vertical shear forces generated by the local loads are to be calculated at the transverse bulkhead positions of the middle tank of the FE model. The vertical bending moment distribution generated by the local loads is to be calculated along the length of the middle tank of the three cargo tank FE model. The FE model can be used to calculate the shear forces and bending moments. Alternatively, a simple beam model representing the length of the 3-tank FE model with simply supported ends may be used to determine the shear force and bending moment values.

15.3.2 Horizontal Bending Moment Distribution

For beam and oblique sea conditions, the horizontal bending moment distribution due to dynamic sea pressure and dynamic tank pressure is to be calculated along the length of the middle tank of the FE model.

15.3.3 Local Loads

The following local loads are to be applied for the calculation of hull girder shear forces and bending moments:

- i)* Ship structural weight distribution over the length of the 3-tank model (static loads). Where a simple beam model is used, the weight of the structure of each tank can be distributed evenly over the length of the cargo tank. The structural weight is to be calculated based on a thickness of the net scantlings to be considered as used in the construction of the cargo tank FE model, see 3-A5/3.
- ii)* Weight of cargo and ballast (static loads)
- iii)* Static sea pressure and dynamic wave pressure

iv) Dynamic tank pressure

15.5 Procedure to Adjust Vertical Shear Force Distribution to Target Values

15.5.1 Adjustment in Shear Forces at Transverse Bulkhead Positions

The required adjustment in shear forces at the transverse bulkhead positions (ΔQ_{aft} and ΔQ_{fwd} as shown in 3-A5/15.5.4 FIGURE 13) are to be generated by applying vertical load at the frame positions as shown in 3-A5/15.5.4 FIGURE 14. It is to be noted that vertical correction loads are not to be applied to any transverse tight bulkheads, any frames forward of the forward tank and any frames aft of the aft tank of the FE model. The sum of the total vertical correction loads applied is equal to zero.

15.5.2 Adjustment in Shear Forces at Aft and Forward Transverse Bulkheads of Middle Tank of FE Model (1 September 2012)

The required adjustments in shear forces at the aft and forward transverse bulkheads of the middle tank of the FE model in order to generate the required target shear forces at the bulkheads are given by:

$$\Delta Q_{aft} = -Q_{targ} - Q_{aft}$$

$$\Delta Q_{fwd} = Q_{targ} - Q_{fwd}$$

where

ΔQ_{aft} = required adjustment in shear force at aft bulkhead of middle tank

ΔQ_{fwd} = required adjustment in shear force at forward bulkhead of the middle tank

Q_{targ} = required shear force value to be achieved at forward bulkhead of middle tank, see 3-A5/13.5.2

Q_{aft} = shear force due to local loads at aft bulkhead of middle tank

Q_{fwd} = shear force due to local loads at fore bulkhead of middle tank

15.5.3 Vertical Loads to be Applied to Each Frame

The value of the vertical loads to be applied to each frame to generate the increase in shear force at the bulkheads may be calculated using a simple beam model. For the case where an uniform frame spacing is used within each tank, the amount of vertical force to be distributed at each frame may be calculated in accordance with the equations below. The length and frame spacing of individual cargo tanks may be different.

$$\delta W_1 = \frac{\Delta Q_{aft}(2\ell - \ell_2 - \ell_3) + \Delta Q_{fwd}(\ell_2 + \ell_3)}{(n_1 - 1)(2\ell - \ell_1 - 2\ell_2 - \ell_3)}$$

$$\delta W_2 = \frac{(W_1 + W_3)}{(n_2 - 1)} = \frac{(\Delta Q_{aft} - \Delta Q_{fwd})}{(n_2 - 1)}$$

$$\delta W_3 = \frac{-\Delta Q_{fwd}(2\ell - \ell_1 - \ell_2) - \Delta Q_{aft}(\ell_1 + \ell_2)}{(n_3 - 1)(2\ell - \ell_1 - 2\ell_2 - \ell_3)}$$

$$F = 0.5 \left(\frac{W_1(\ell_2 + \ell_1) - W_3(\ell_2 + \ell_3)}{\ell} \right)$$

where

ℓ_1 = length of aft cargo tank of model

ℓ_2 = length of middle cargo tank of model

ℓ_3 = length of forward cargo tank of model

ΔQ_{aft}	=	required adjustment in shear force at aft bulkhead of middle tank, see 3-A5/15.5.4 FIGURE 13
ΔQ_{fwd}	=	required adjustment in shear force at fore bulkhead of middle tank, see 3-A5/15.5.4 FIGURE 13
F	=	end reactions due to application of vertical loads to frames.
$W1$	=	total evenly distributed vertical load applied to aft tank of FE model
	=	$(n_1 - 1)\delta w_1$
$W2$	=	total evenly distributed vertical load applied to middle tank of FE model
	=	$(n_2 - 1)\delta w_2$
$W3$	=	total evenly distributed vertical load applied to forward tank of FE model
	=	$(n_3 - 1)\delta w_3$
n_1	=	number of frame spaces in aft cargo tank of FE model
n_2	=	number of frame spaces in middle cargo tank of FE model
n_3	=	number of frame spaces in forward cargo tank of FE model
δw_1	=	distributed load at frame in aft cargo tank of FE model
δw_2	=	distributed load at frame in middle cargo tank of FE model
δw_3	=	distributed load at frame in forward cargo tank of FE model
$\Delta \ell_{end}$	=	distance between end bulkhead of aft cargo tank to aft end of FE model
$\Delta \ell_{fore}$	=	distance between fore bulkhead of forward cargo tank to forward end of FE model
ℓ	=	total length of FE model (beam) including portions beyond end bulkheads:
	=	$\ell_1 + \ell_2 + \ell_3 + \Delta \ell_{end} + \Delta \ell_{fore}$

<i>Notes</i>	1	Positive direction of loads, shear forces and adjusting vertical forces in the formulae is in accordance with 3-A5/15.5.4 FIGURE 13 and 3-A5/15.5.4 FIGURE 14.
	2	$W1 + W3 = W2$

15.5.4 Adjusting Load to be Applied to Structural Parts of Transverse Frames

The amount of adjusting load to be applied to the structural parts of each transverse frame section to generate the vertical load, δw_i , is to be in accordance with 3-A5/11.5.3 FIGURE 8. This load is to be distributed at the finite element grid points of the structural parts. Where 4-node or 3-node finite plate elements are used, the load to be applied at each grid point of a plate element is given by:

$$F_{i-grid} = \frac{\sum_1^n 0.5 A_{i- elem}}{A_s} F_s$$

where

- F_{i-grid} = load to be applied to the i – th FE grid point on the individual structural member under consideration (i.e., side shell, longitudinal bulkheads and bottom girders, inner hull longitudinal bulkheads, hopper plates, upper slope plates of inner hull and outboard girders as defined in 3-A5/15.5.4 FIGURE 15)
- $A_{i- elem}$ = sectional area of each plate element in the individual structural member under consideration (see 3-A5/15.5.4 FIGURE 15), which is connected to the i – th grid point
- n = number of plate elements connected to the i – th grid point
- F_S = total load applied to an individual structural member under consideration, as specified in 3-A5/15.5.4 FIGURE 15
- A_S = plate sectional area of the individual structural member under consideration (i.e., side shell, longitudinal bulkheads, bottom girders, inner hull longitudinal bulkheads, hopper plates, upper slope plates of inner hull and outboard girders as defined in 3-A5/15.5.4 FIGURE 15)

FIGURE 13
Position of Target Shear Force and Required Shear Force Adjustment at Transverse Bulkhead Positions

Condition	Target			Aft Bhd		Fore Bhd	
	BM	SF	Bhd pos	SF	ΔQ_{aft}	SF	ΔQ_{fwd}
	Hog	- ve	Fore	$- Q_{targ}$	$- Q_{targ} - Q_{aft}$	$Q_{targ}(- ve)$	$Q_{targ} - Q_{fwd}$
	Hog	- ve	Fore	$- Q_{targ}$	$- Q_{targ} - Q_{aft}$	$Q_{targ}(- ve)$	$Q_{targ} - Q_{fwd}$

Condition	Target			Aft Bhd		Fore Bhd	
	BM	SF	Bhd pos	SF	ΔQ_{aft}	SF	ΔQ_{fwd}
	Sag	+ve	Fore	-Qtarg	-Qtarg - Qaft	Qtarg(+ve)	Qtarg - Qfwd
	Sag	+ve	Fore	-Qtarg	-Qtarg - Qaft	Qtarg(+ve)	Qtarg - Qfwd

Note For definition of symbols, see 3-A5/15.5.2.

FIGURE 14
 Distribution of Adjusting Vertical Force at Frames and Resulting Shear Force Distributions

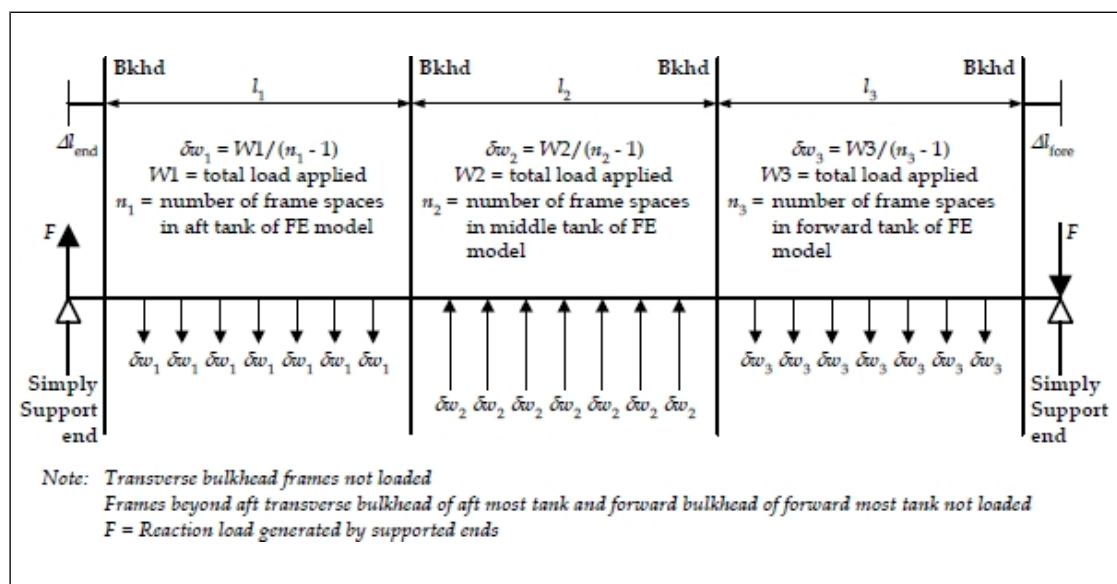

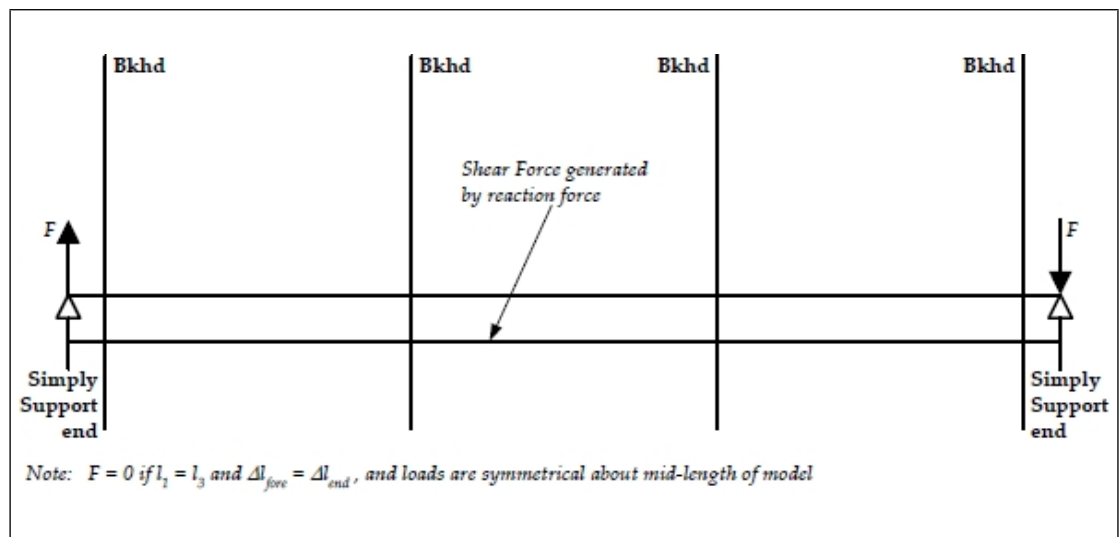
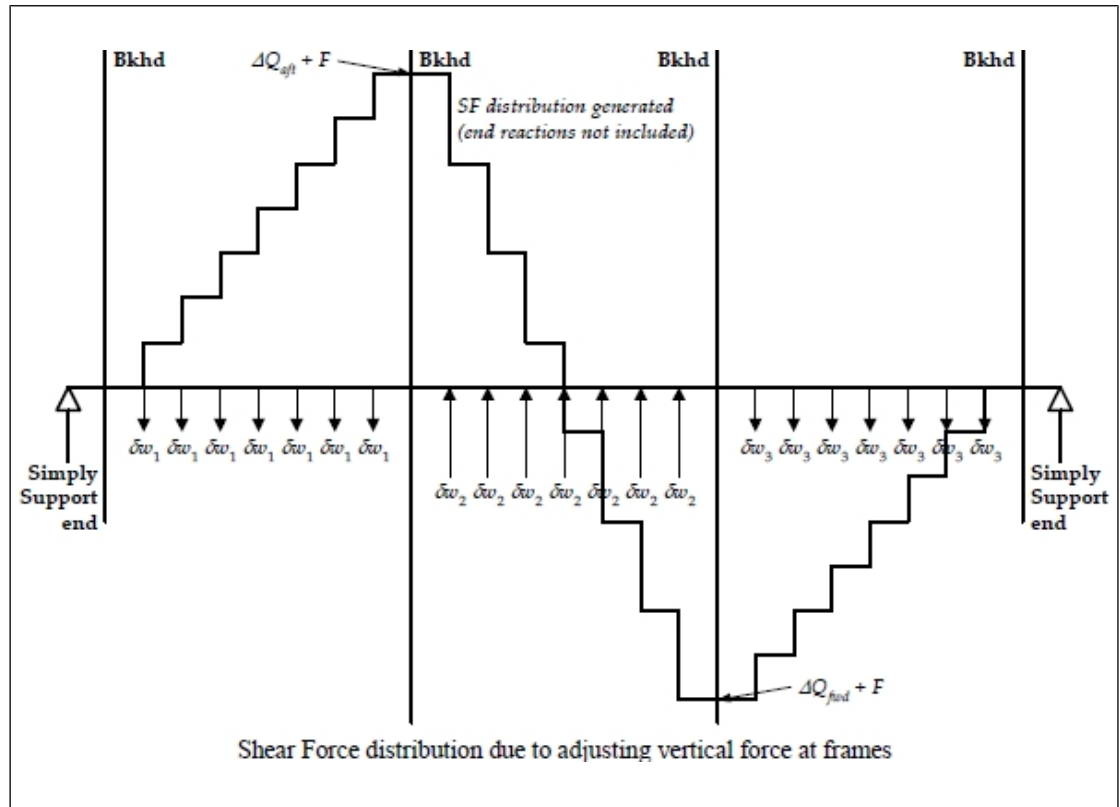

Note For definition of symbols, see 3-A5/15.5.3.

FIGURE 15
Distribution of Adjusting Load on a Transverse Section

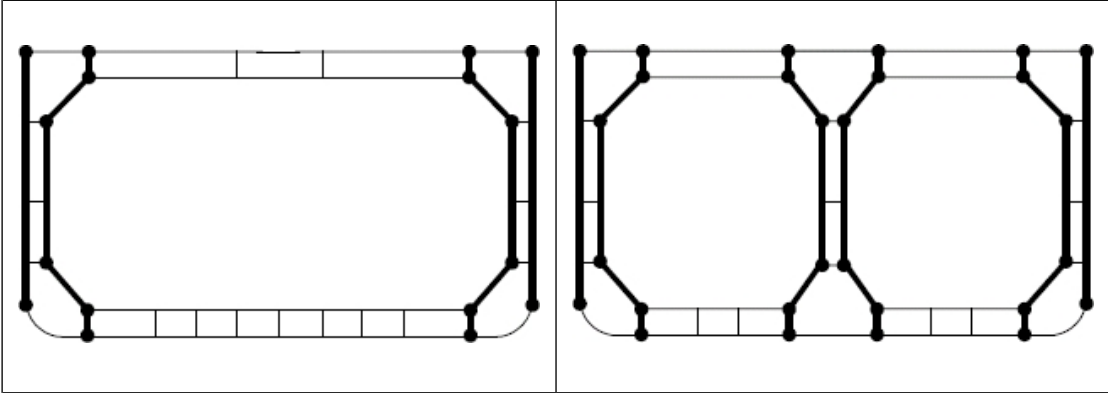

<i>Structural Member</i>	<i>Applied Load F_s</i>
Side Shell	$f \cdot \delta w_i$
Cofferdam bulkhead including bottom girder beneath	$f \cdot \delta w_i$
Inner hull longitudinal bulkhead (vertical part)	$f \cdot \delta w_i \cdot \frac{A_{Ih}}{A_2}$
Hopper plate	$f \cdot \delta w_i \cdot \frac{A_{Hp}}{A_2}$
Upper slope plating of inner hull	$f \cdot \delta w_i \cdot \frac{A_{Usp}}{A_2}$
Outboard girder	$f \cdot \delta w_i \cdot \frac{A_{Og}}{A_2}$

Where

δw_i	=	vertical load to be applied to each transverse frame section, see 3-A5/15.5.3
f	=	shear force distribution factor of structural part calculated at the mid-tank position in accordance with 3-A5/Table 1
A_{Ih}	=	plate sectional area of individual inner hull longitudinal bulkhead
A_{Hp}	=	plate sectional area of individual hopper plate
A_{Usp}	=	Plate sectional area of individual upper slope plate of inner hull
A_{Og}	=	plate sectional area of individual outboard girder
A_2	=	plate sectional area calculated in accordance with 3-A5/Table 1

Notes:

- 1 Adjusting load is to be applied in plane to the hopper slope plate and upper slope plate of inner hull.
- 2 Adjusting load given is to be applied to individual structural member.

TABLE 1
Shear Force Distribution Factors

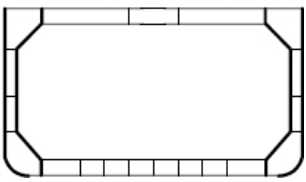
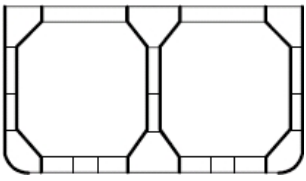
	Side Shell	$f = 0.128 + 0.1052 \frac{A_1}{A_2}$
	Inner hull	$f = 0.372 - 0.105 \frac{A_1}{A_2}$
	Side Shell	$f = 0.028 + 0.087 \frac{A_1}{A_2} + 0.023 + \frac{A_2}{A_3}$
	Inner hull	$f = 0.119 - 0.038 \frac{A_1}{A_2} + 0.072 \frac{A_2}{A_3}$
	Cofferdam bulkhead	$f = 0.353 - 0.049 \frac{A_1}{A_2} - 0.095 \frac{A_2}{A_3}$
<p>Where</p> <p>A_1 = plate sectional area of individual side shell (i.e., on one side), including bilge</p> <p>A_2 = plate sectional area of individual inner hull longitudinal bulkhead (i.e., on one side), including hopper slope plate, double bottom side girder in way and, where fitted, upper slope plating of inner hull.</p> <p>A_3 = plate sectional area of cofferdam bulkhead, including double bottom girder in way</p>		

Notes:

- 1 Where part of the structural member is not vertical, the area is to be calculated using the projected area in the vertical direction.
- 2 All plate areas are to be calculated based on the modeled thickness of the cargo tank FE model.

15.7 Procedure to Adjust Vertical and Horizontal Bending Moments to Target Values (1 September 2012)

15.7.1 End Vertical Bending Moment

An additional vertical bending moment is to be applied at both ends of the cargo tank finite element model to generate the required target vertical bending moment in the middle tank of the model. This end vertical bending moment can be calculated as follows:

$$M_{v-end} = M_{v-targ} - M_{v-peak}$$

where

M_{v-end} = additional vertical bending moment to be applied at both ends of finite element model

M_{v-targ} = required target hogging (positive) or sagging (negative) vertical bending moment, as specified in 3-A5/13.5.1

M_{v-peak}	=	maximum or minimum bending moment within the length of the middle tank due to the local loads described in 3-A5/15.3.3 and the additional vertical loads applied to generate the required shear force, see 3-A5/15.5. M_{v-peak} is to be taken as the maximum bending moment if M_{v-targ} is hogging (positive) and as the minimum bending moment if M_{v-targ} is sagging (negative). M_{v-peak} can be obtained from FE analysis. Alternatively, M_{v-peak} may be calculated as follows based on a simply supported beam model:
	=	$max\{M_o + xF + M_{lineload}\}$
M_o	=	vertical bending moment at position x , due to the local loads described in 3-A5/15.3.3
$M_{lineload}$	=	vertical bending moment at position x , due to application of vertical line loads at frames to generate required shear force, see 3-A5/15.5
F	=	reaction force at ends due to application of vertical loads to frames, see 3-A5/15.5
x	=	longitudinal position of frame in way of the middle tank of FE model from end, see 3-A5/15.5

15.7.2 End Horizontal Bending Moment

For beam and oblique sea load cases, an additional horizontal bending moment is to be applied at the ends of the cargo tank FE model to generate the required target horizontal bending moment at a section within the length of the middle tank of the model. The additional horizontal bending moment can be calculated as follows:

$$M_{h-end} = M_{h-targ} - M_{h-peak}$$

where

M_{h-end}	=	additional horizontal bending moment to be applied to ends of FE model
M_{h-targ}	=	required target positive or negative horizontal bending moment, see 3-A5/13.7
M_{h-peak}	=	maximum or minimum horizontal bending moment within the length of the middle tank due to the local loads described in 3-A5/15.3.3. M_{h-peak} is to be taken as the maximum horizontal bending moment if M_{h-targ} is positive (starboard side in tension) and as the minimum horizontal bending moment if M_{h-targ} is negative (port side in tension).

15.7.3 Application of End Bending Moments to Achieve Target Values

The vertical and horizontal bending moments should be calculated over the length of the middle tank of the FE model to identify the position and value of each maximum/minimum bending moment as specified in 3-A5/15.7.1 and 3-A5/15.7.2.

The additional vertical bending moment, M_{v-end} , and horizontal bending moment, M_{h-end} , are to be applied to both ends of the cargo tank model.

The vertical and horizontal bending moments may be applied at the model ends by distributing axial nodal forces to all longitudinal elements according to the simple beam theory as follows:

$$(F_x)_i = \frac{M_{v-end}}{I_z} \frac{A_i}{n_i} y_i \quad \text{for vertical bending moment}$$

$$(F_x)_i = \frac{M_{h-end}}{I_y} \frac{A_i}{n_i} z_i \quad \text{for horizontal bending moment}$$

where

- M_{v-end} = vertical bending moment to be applied to the ends of the model
- M_{h-end} = horizontal bending moment to be applied to the ends of the model
- $(F_x)_i$ = axis force applied to a node of the i – th element
- I_z = hull girder vertical moment of inertial of the end section about its horizontal neutral axis
- I_y = hull girder horizontal moment of inertial of the end section about its vertical neutral axis (normally centerline)
- y_i = vertical distance from the neutral axis to the centre of the cross sectional area of the i – th element
- z_i = horizontal distance from the neutral axis to the centre of the cross sectional area of the i – th element
- A_i = cross sectional area of the i – th element
- n_i = number of nodal points of i – th element on the cross section, $n_i = 2$ for 4-node plate element

17 Boundary Conditions

17.1 General

All boundary conditions described in this Subsection are in accordance with the global co-ordinate system defined in 3-A5/7. The boundary conditions to be applied at the ends of the cargo tank FE model are given in 3-A5/17.1 TABLE 2. The analysis may be carried out by applying all loads to the model as a complete load case or by combining the stress responses resulting from several separate sub-cases.

Ground spring elements, i.e., spring elements with one end constrained in all 6 degrees of freedom, with stiffness in global z degree of freedom are to be applied to the grid points along deck, inner bottom and bottom shell as shown in 3-A5/17.1 FIGURE 16.

Ground spring elements with stiffness in global y degree of freedom are to be applied to the grid points along the vertical part of the side shells, inner hull longitudinal bulkheads and oil-tight longitudinal bulkheads as shown in 3-A5/17.1 FIGURE 16.

FIGURE 16
Spring Constraints at Model Ends

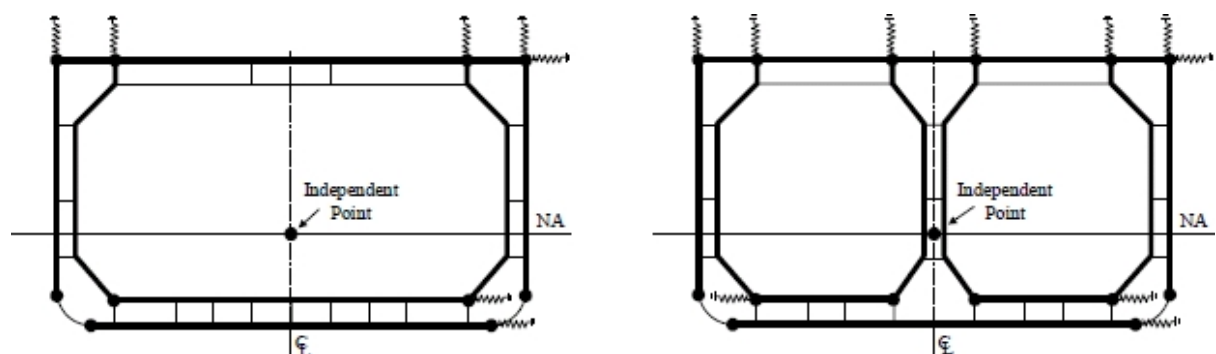

TABLE 2
Boundary Constraints at Model Ends

<i>Location</i>	<i>Translation</i>			<i>Rotation</i>		
	δ_x	δ_y	δ_z	θ_x	θ_y	θ_z
Aft End						
Aft end (all longitudinal elements)	RL	-	-	-	RL	RL
Independent point aft end, see 3-A5/Figure 16	Fix	-	-	-	$M_h - end$	$M_v - end$
Deck, inner bottom, inner deck and outer shell	-	Springs	-	-	-	-
Side, inner skin, and longitudinal cofferdam bulkheads	-	-	Springs	-	-	-
Fore End						
Fore end (all longitudinal elements)	RL	-	-	-	RL	RL
Independent point fore end, see 3-A5/Figure 16	-	-	-	-	$M_h - end$	$M_v - end$
Deck, inner bottom, inner deck and outer shell	-	Springs	-	-	-	-
Side, inner skin, and longitudinal cofferdam bulkheads	-	-	Springs	-	-	-

Where:

- No constraint applied (free)
- RL Nodal points of all longitudinal elements rigidly linked to independent point at neutral axis on centerline

Notes:

- 1 All translation and rotation displacements are in accordance with the global coordinate system defined in 3-A5/7.
- 2 Where $M_h - end$ is not applied, the independent points at the fore and aft ends are to be free in θ_y .
- 3 Where $M_v - end$ is not applied, the independent points at the fore and aft ends are to be free in θ_z .
- 4 Where no bending moment is applied, the independent points at the fore and aft ends are to be free in θ_y and θ_z .
- 5 Where bending moment is applied as nodal forces, the independent points at the fore and aft ends are to be free in the corresponding degree of freedom of rotations (i.e. θ_y and/or θ_z).

17.3 Calculation of Spring Stiffness

The springs are typically represented by rod elements, having only axial stiffness. The stiffness is equivalent to the support given to the considered end bulkhead by the cutout longitudinal structural members. The resulting cross-sectional can be determined by the following formula:

$$A = \left(\frac{1}{1 + \nu} \right) \frac{A_s \ell}{\ell_{tk} n} = 0.77 \frac{A_s \ell}{\ell_{tk} n} \text{ cm}^2$$

where

- A = cross-sectional area of the bar, in cm^2
- A_s = shearing area of the individual structural member under consideration (i.e., plating of deck, inner bottom, bottom shell, side shell, inner hull longitudinal bulkheads or oil-tight longitudinal bulkhead). A_s is to be calculated based on the thickness of the cargo tank finite element model for areas indicated in 3-A5/17.3 TABLE 3 for the appropriate structural member under consideration, in cm^2

- ν = Poisson's ratio of the material, taken as 0.3
- ℓ_{tk} = length of cargo tank, between bulkheads of the middle tank of the FE model, in cm
- n = number of nodal points to which the spring elements are applied to the structural member under consideration
- ℓ = length of the bar, in cm

The bar area A is determined by a given bar length ℓ , which can be any value. In practice, however, all values of ℓ in the finite element model are conveniently chosen to be the same round figure, for example, equal to 100 cm.

One end of the rod is to be constrained in all six degrees of freedom.

TABLE 3
Shear Areas to be Considered for the Calculation of Spring Stiffness

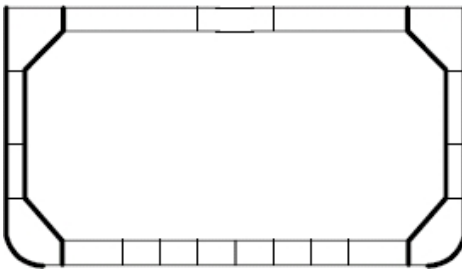
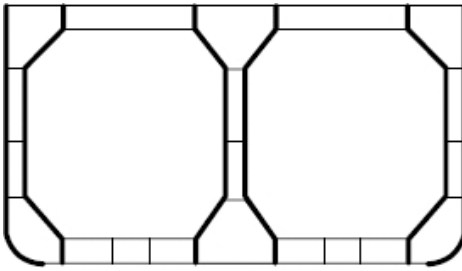
Vertical springs		
	Side	Area of side shell plating, including bilge
	Inner hull longitudinal bulkheads	Area of inner skin plating, including inner deck side girder, hopper slope plate and double bottom side girder in way
	Longitudinal cofferdam bulkheads	Area of longitudinal cofferdam bulkhead plating, including inner deck side girder, and double bottom girder in way
	Where part of the structural member is not vertical, the area is to be calculated using the projected area in the vertical direction.	
Horizontal springs		

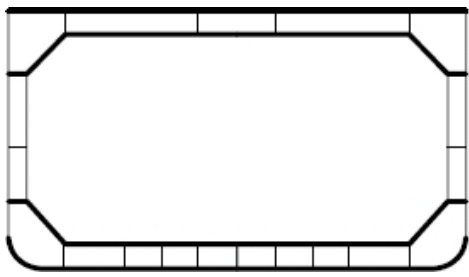
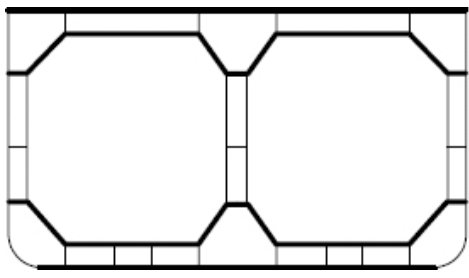
	Deck	Area of deck plating
	Inner bottom	Area of inner bottom plating, including hopper slope plate longitudinal cofferdam slope plate, lower longitudinal stool plate and horizontal stringer in way
	Inner deck	Area of inner deck plating, including longitudinal bulkhead slope plate, longitudinal cofferdam slope plate, upper longitudinal stool plate and horizontal stringer in way
	Bottom shell	Area of bottom shell plating, including bilge
	Where part of the structural member is not horizontal the area is to be calculated using the projected area in the horizontal direction.	

19 Validation of 3-D Global Response

19.1 Correlation with Beam Theory

It has been shown that the primary hull girder bending stress and deflection obtained by the finite element analysis are in good agreement with classical beam theory results, even with the open deck configuration of the hull girder. In order to verify that proper modeling of the hull structure has been made, and that appropriate loading and boundary conditions have been imposed on the model, it is useful to compare the results with that obtained by beam theory. The check is usually carried out for the vertical bending moment since it is the most predominate bending moment and for which a high proportion of the hull girder section modulus is used.

The comparison should be made in areas where local loads have minimal effects and also at the minimum section modulus, i.e., mid-hold. The best correlation is obtained at the deck at side where the section modulus is calculated for and also has the minimum effect of local loading.

Because of secondary bending, shear lag, or stresses due to alternate hold or upper wing ballast loading, some variation in hull girder bending stresses can be expected between the resultant FEA stresses as compared to classical beam theory stresses.

19.3 Additional Remarks

When comparison of hull girder stresses shows good correlation with beam theory, it can be concluded that the overall response of the finite element model to applied loads is correct.

However, it is still possible that at some local areas of the model, stress levels and deflections are not consistent with the applied loading. A large-scale local deflection display of the questionable area will usually provide some clues as to the cause for such unreasonable results. If it is a problem of element connectivity, the display will clearly show a separation of adjoining members. Certainly, errors in element properties are always a possibility, and can be easily checked in the appropriate display of the model.

In general, the experienced or knowledgeable user should be able to predict the structural behavior and stress level distributions under the specified loading. There will be logical conclusions for any variance in the predicted stress and deformation patterns of the finite element model.

If possible, it is recommended that before starting the structural analysis, the engineer should take the time to review previously-performed structural analyses on similar installations, in order to better visualize the analysis procedures and resultant structural response.

21 Detailed Stress Assessment - Local FEA

21.1 General

21.1.1 Application

This Subsection describes the procedure for the detailed stress assessment with refined meshes to evaluate highly stressed areas of primary supporting members.

21.3 Analysis Model

21.3.1 Areas to be Refined

Where the global cargo hold analysis is carried out using a model complying with the modeling criteria of this Appendix, the areas listed in 3-A5/11.5 are to be refined at the locations whose calculated stresses exceed 95% of the allowable stress as specified in 3-5/3.3.

21.3.2 Refining Method

Two methods can be used for refining the high stressed areas:

- Detailed stresses in refined areas can be analyzed by separate sub-models.
- Refined areas can be directly included in FE model used for the global cargo hold analysis.

21.3.3 Modeling

21.3.3(a) Element Type. Each structural member is to be modeled by using proper element type for the structure in accordance with the principle in this guidance.

21.3.3(b) Mesh. The element size in refined areas is to be approximately one fourth of the representative spacing of ordinary stiffeners in the corresponding area (i.e., 200 × 200 mm mesh size for structures whose ordinary stiffener spacing is 800 mm). In addition, the web height of primary supporting members is to be divided at least into 3 elements.

The aspect ratio of element is not to exceed 3. Quad elements are to have 90° angles as much as practicable, or to have angles between 45° and 135°.

21.3.3(c) Extent of Sub-model. The minimum extent of sub-model is to be such that the boundaries of the sub-model correspond to the locations of adjacent supporting members.

21.3.4 Loading Conditions

Loading conditions, which are applied to the 3-D FE model for the global cargo hold analysis, are to be considered in the detailed stress assessment.

21.3.5 Boundary Conditions

Nodal forces or nodal displacements obtained from the global cargo hold analysis are to be applied to the sub-models. Where nodal forces are given, the supporting members located at the boundaries of a sub-model are to be included in the sub-model. Where nodal displacements are given and additional nodes are provided in sub-models, nodal displacements at the additional nodes are to be determined by proper interpolations.

21.5 Analysis Criteria

21.5.1 Allowable Stress

Von Mises equivalent stresses in plate elements and axial stresses in line elements within refined areas are not to exceed the allowable stresses specified in 3-5/3.9.

CHAPTER 3 Structural Design Requirements

APPENDIX 6 Guide for Offshore Hull Construction Monitoring Program

1 Introduction

The structural strength criteria specified in the ABS Rules are used by designers to establish acceptable scantlings in order that a vessel constructed to such standards and properly maintained will have adequate durability and capability to resist the failure modes of yielding, buckling and fatigue.

The application of the *FLGT Guide* and other review techniques to assess a design for compliance with Rule criteria also gives the designer and ABS the ability to identify areas that are considered critical to satisfactory in-service performance.

Knowing that the actual structural performance is also a function of construction methods and standards, it is prudent to identify ‘critical’ areas, particularly those approaching design limits, and use appropriate specified construction quality standards and associated construction monitoring and reporting methods to limit the risk of unsatisfactory in-service performance.

Accordingly, this Guide defines what is meant by critical areas, describes how they are to be identified and recorded, delineates what information the shipyard is to include in the construction monitoring plan and lays out the certification regime to be followed.

3 Application

Floating Liquefied Gas Terminals designed and reviewed to the *FLGT Guide* are to comply with the requirements of this Appendix and have the notation **OHCM**.

5 Critical Area

The term *critical area*, as used in this Guide, is defined as an area within the structure that may have a higher probability of failure during the life of the vessel compared to the surrounding areas, even though they may have been modified in the interest of reducing such probability. The higher probability of failure can be a result of stress concentrations, high stress levels and high stress ranges due to loading patterns, structural discontinuities or a combination of these factors.

In order to provide an even greater probability of satisfactory in-service performance, the areas that are approaching the acceptance criteria can be identified so that additional attention may be paid during fabrication.

The objective of heightened scrutiny of building tolerance and monitoring in way of the critical areas is to minimize the effect of stress increases incurred as a result of the construction process. Improper alignment and fabrication tolerances may be potentially influential in creating construction-related stress.

7 Determination of Critical Areas

Critical areas can be determined in a number of ways, including but not limited to:

- i) The results of engineering strength and fatigue analyses, such as specified in the *FLGT Guide*, Finite Element Analysis or a Dynamic Loading Approach analysis, particularly for areas approaching the allowable criteria.
- ii) The application of ABS Rules, such as 3-1-2/15.3.
- iii) Details where fabrication is difficult, such as blind alignment, complexity of structural details and shape, limited access, etc.
- iv) Input from owners, designers and/or shipyards based on previous in-service experience from similar vessels, such as corrosion, wear and tear, etc.

9 Construction Monitoring Plan

A Construction Monitoring Plan for critical areas is to be prepared by the shipyard and submitted for approval prior to the start of fabrication. The plan is to include:

- i) Structural drawings indicating the location of critical areas as identified by the ABS review (see 3-A6/7).
- ii) Construction standards and control procedures to be applied.
- iii) Verification and recording procedures at each stage of construction, including any proposed nondestructive testing.
- iv) Procedures for defect correction.

An approved copy of the Construction Monitoring plan is to be placed onboard the floating terminal.

11 Surveys After Construction

To monitor critical areas during service, an approved copy of the Construction Monitoring Plan should be available for all subsequent surveys.

13 Notation

Floating terminals having been found in compliance with the requirements of this Guide may be distinguished in the *Record* with the notation **OHCM**.

CONTENTS

SECTION	1	Surveys During Construction, Installation and Commissioning.	351
	1	General.....	351
	3	Construction Surveys.....	351
	3.1	General.....	351
	3.3	Survey at Vendor's Shop.....	351
	3.5	Structure Fabrication/Erection.....	351
	3.7	Liquefied Gas Containment and Handling Systems.....	353
	3.9	Process Systems.....	354
	3.11	Piping.....	354
	3.13	Electrical.....	354
	3.15	Instrumentation.....	354
	3.17	Mechanical.....	354
	5	Installation, Hook-up and Commissioning Surveys.....	355
	5.1	Installation Surveys.....	355
	5.3	Commissioning Surveys.....	355
	5.5	Personnel Safety.....	355
SECTION	2	Surveys After Construction and Maintenance of Class.....	356
	1	General.....	356
	1.1	Notification and Availability for Survey.....	356
	3	Surveys.....	356
	3.1	Annual Survey.....	356
	3.3	Intermediate Survey.....	356
	3.5	Special Periodical Survey.....	357
	3.7	Continuous Survey Program.....	357
	3.9	Survey Based on Preventative Maintenance Techniques.....	357
	3.11	In-line Surveys and Timing of Surveys.....	357
	3.13	Drydocking Surveys.....	357
	3.15	Boiler Surveys.....	358
	3.17	Tailshaft/Tubeshaft Surveys.....	358
	5	Survey Reports File.....	358

	5.1	Annual Survey.....	359
	5.3	Intermediate Survey.....	362
	5.5	Special Periodical Survey.....	362
	5.7	Drydocking Survey.....	368
	5.9	Boiler Survey.....	370
	5.11	Tailshaft/Tubeshaft Survey.....	370
7		Survey and Inspection Plan.....	370
9		Modifications.....	370
11		Damage and Repairs.....	370
	11.1	370
	11.3	371
	11.5	371
13		Certification on Behalf of Coastal and Flag States.....	371
15		Welding and Replacement of Materials.....	371
	15.1	Ordinary and Higher Strength Structural Steels.....	371
SECTION	3	Risk-based Surveys for Maintenance of Class.....	372
	1	General.....	372
	1.1	Applicability.....	372
	1.3	Survey Periods.....	372
	3	Requirements for Risk-based Survey.....	372
	3.1	General.....	372
	3.3	Site-Specific Risk Assessment.....	373
	5	Surveys.....	373
	5.1	General.....	373
	5.3	Initial Survey.....	373
	5.5	Annual Survey.....	373
	5.7	Special Periodical Survey.....	373
	7	Modifications.....	374
	9	Damage and Repairs.....	374
	11	Certification on Behalf of Coastal and Flag States.....	374

Surveys During Construction, Installation and Commissioning

1 General

This Section pertains to surveys and inspections during construction, installation and commissioning of a floating offshore liquefied gas terminal. The documentation requirements for review are given in 2-1/13 of this Guide. A general quality plan highlighting required surveys together with ABS hold points is to be determined by the builder and agreed upon by the attending Surveyor.

3 Construction Surveys

3.1 General

During construction of equipment components for an offshore liquefied gas terminal, the attending Surveyor is to have access to vendors' facilities to witness construction and/or testing, as required by this Guide. The vendor is to contact the attending Surveyor to make necessary arrangements. If the attending Surveyor finds reason to recommend repairs or additional surveys, notice will be immediately given to the Owner or Owner's Representative so that appropriate action may be taken. Coordination of the vendors' certification program is carried out through ABS' Vendor Coordinators.

3.3 Survey at Vendor's Shop

Survey requirements for equipment components and packaged units at the vendor's shop are summarized in relevant sections of applicable ABS Rules/Guides. Each vendor is required to have an effective quality system which is to be verified by the attending Surveyor.

3.5 Structure Fabrication/Erection

A Quality Control Program (QCP) compatible with the type, size and intended service of the terminal is to be developed and submitted to ABS for approval. Required hold points on the QCP that is to form the basis for all future ABS surveys at the fabrication yard shall be agreed upon by the attending Surveyor. As a minimum, all of the items enumerated in the following applicable Subsections are to be covered by the QCP. ABS shall verify that all tests and inspections specified in the QCP are satisfactorily carried out by a competent person, and ABS surveys shall be considered to supplement and not replace inspections that should be carried out by the fabricator or operator.

The fabricator is to maintain a system of material traceability to the satisfaction of the attending Surveyor. Data as to place of origin and results of tests for materials shall be retained and are to be readily available to ABS upon request.

Where equipment and components are assembled in blocks or modules, the Surveyor is to inspect the fit-up, piping and electrical connections, and to witness the required tests on the completed assembly in guidance with the QCP and in accordance with the approved plans and Rule/Guide requirements. The progress and suitability of structural fit-up and joining of constructed/fabricated blocks/modules are to be to the satisfaction of the attending Surveyor. All erection joints are to be subjected to visual examination, proven tight, and the extent of Non-Destructive Examination (NDE) carried out is to be to the satisfaction of the attending Surveyor.

3.5.1 Surveys on Steel Structures

3.5.1(a) Quality Control Program. The quality control program for the construction of a steel terminal is to include the following items, as appropriate.

- Material quality and traceability
- Steel Forming
- Welder qualification and records
- Welding procedure specifications and qualifications
- Weld inspection
- Tolerances alignments and compartment testing
- Corrosion control systems
- Tightness and hydrostatic testing procedures
- Nondestructive testing
- Installation of main structure

The items which are to be considered for each of the topics, mentioned above are indicated in 4-1/3.5.1(b) through 4-1/3.5.1(j).

3.5.1(b) Material Quality and Traceability. The properties of the material are to be in accordance with the *ABS Rules for Materials and Welding (Part 2)*. Manufacturer's certificates are to be supplied with the material. Verification of the material's quality is to be done by the Surveyor at the plant of manufacture, in accordance with *ABS Rules for Materials and Welding (Part 2)*. Alternatively, material manufactured to recognized standards may be accepted in lieu of the above steel requirements provided the substitution of such materials is approved by ABS. Materials used are to be in accordance with those specified in the approved design and all materials required for classification purposes are to be tested in the presence of an ABS Surveyor. The Constructor is to maintain a material traceability system for all the primary and special application structures.

3.5.1(c) Steel Forming. When forming changes base plate properties beyond acceptable limits, appropriate heat treatments are to be carried out to reestablish required properties. Unless approved otherwise, the acceptable limits of the reestablished properties should meet the minimums specified for the original material before forming. ABS will survey formed members for their compliance with the forming dimensional tolerances required by the design.

3.5.1(d) Welder Qualification and Records. Welders who are to work on the structure are to be qualified in accordance with the welder qualification tests specified in a recognized code or, as applicable, *ABS Rules for Materials and Welding (Part 2)* to the satisfaction of the attending Surveyor. Certificates of qualification are to be prepared to record evidence of the qualification of each welder qualified by an approved standard/code, and such certificates are to be available for the use of the Surveyors. In the event that welders have been previously tested in accordance with the requirements of a recognized code and provided that the period of effectiveness of the previous testing has not lapsed, these welder qualification tests may be accepted.

3.5.1(e) Welding Procedure Specifications and Qualifications. Welding procedures are to be approved in accordance with *ABS Rules for Materials and Welding (Part 2)*. Welding procedures conforming to the provisions of a recognized code may, at the Surveyor's discretion, be accepted. A written description of all procedures previously qualified may be employed in the structure's construction provided it is included in the quality control program and made available to the Surveyors. When it is necessary to qualify a welding procedure, this is to be accomplished by employing the methods specified in the recognized code, and in the presence of the Surveyor.

3.5.1(f) Weld Inspection. As part of the overall quality control program, a detailed plan for the inspection and testing of welds is to be prepared and this plan is to include the applicable provisions of the *Marine Vessel Rules*.

3.5.1(g) Tolerances and Alignments. The overall structural tolerances, forming tolerances, and local alignment tolerances are to be commensurate with those considered in developing the structural design. Inspections are to be carried out to verify that the dimensional tolerance criteria are being met. Particular attention is to be paid to the out-of-roundness of members for which buckling is an anticipated mode of failure. Structural alignment and fit-up prior to welding shall be monitored to promote consistent production of quality welds.

3.5.1(h) Corrosion Control Systems. The details of any corrosion control systems employed for the structure are to be submitted for review. Installation and testing of the corrosion control systems are to be carried out to the satisfaction of the attending Surveyor in accordance with the approved plans.

3.5.1(i) Tightness and Hydrostatic Testing Procedures. Compartments which are designed to be permanently watertight or to be maintained watertight during installation are to be tested by a procedure approved by the attending Surveyor. The testing is also to be witnessed by the attending Surveyor.

3.5.1(j) Nondestructive Testing. A system of nondestructive testing is to be included in the fabrication specification of the structures. The minimum extent of nondestructive testing shall be in accordance with the *ABS Guide for Nondestructive Inspection of Hull Welds* or recognized design Code. All nondestructive testing records are to be reviewed and approved by the attending Surveyor. Additional nondestructive testing may be requested by the attending Surveyor if the quality of fabrication is not in accordance with industry standards.

3.7 Liquefied Gas Containment and Handling Systems

3.7.1 Liquefied Gas Storage Tank, LNG and GNG Piping System Fabrication

All liquefied gas storage tanks or storage systems and LNG and GNG piping systems are to be fabricated in accordance with approved plans to the satisfaction of the Surveyor and in compliance with the manufacturer's approved quality assurance program and fabrication procedures. The ABS Surveyor will verify the use of ABS-certified materials for the tank shell and or membranes, piping components and insulation systems. Welders, weld procedures, nondestructive examination procedures, equipment and personnel will all be qualified by the Surveyor who will monitor the phases of liquefied gas tank construction and review fabrication reports and NDE records. The ABS Surveyor will attend and report on all pressure testing and tightness testing during the entire fabrication period.

3.7.2 Liquefied Gas Systems Operations Manual

The liquefied gas systems operation/handling manual should be available onboard to all persons concerned, outlining necessary data for the safe storage and handling of liquefied gas. Description contained in the manual is to include, but not be limited to the following:

- i) Outline feature of liquefied gas and GNG systems such as:
 - Principal particulars

- Properties and characteristics of the liquefied gas (range of density and composition)
- Storage tanks, piping, liquefied gas/GNG handling equipment
- Control system and instrumentation
- ii)* Safety systems such as:
 - Fire protection, ventilation, fire detection, fire fighting equipment
 - Personnel protection, safety precautions, equipment
 - Communications
- iii)* Normal operating procedures or cargo handling guidance such as:
 - Inerting, gasing, cooling down, loading, discharging, warming up, aeration
- iv)* An envelope of limiting environmental conditions for carrying out safe operations.
- v)* Emergency operations such as:
 - Cargo leakage or spillage
 - Jettisoning (if applicable)
 - Accepting liquefied gas from a disabled liquefied gas carrier at a load terminal
 - Lightering at a discharge terminal that normally only discharges vapor

3.9 Process Systems

Process pressure vessels, refrigerant storage tanks, heat exchangers piping system components, compressors, pumps and other mechanical equipment and electrical and control systems and equipment that is part of a classed process system will be surveyed during fabrication, installation and testing to the same extent that liquefied gas storage and handling systems are reviewed in accordance with 4-1/3.7 above.

3.11 Piping

All piping installation/testing is to be in accordance with ABS-approved drawings and procedures. Welds are to be visually inspected and nondestructively tested, as required and to the satisfaction of the attending Surveyor. Upon completion of satisfactory installation, the piping system is to be proven tight by hydrostatic testing to the required pressure, but not less than its normal working pressure. Where sections of pipes are hydrostatically tested at the fabrication shops, an onboard test is to be conducted to confirm proper installation and tightness of the flanged and/or welded connections.

3.13 Electrical

All electrical wiring, equipment and systems are to be installed/tested in accordance with ABS-approved drawings and procedures. Proper support for all cables and suitable sealing of cable entries to equipment are to be verified. Upon completion of wire connections, the affected sections of the equipment and cabling are to be insulation-tested and proven in order. All grounding is also to be verified in order.

3.15 Instrumentation

All instrumentation installation/testing is to be in accordance with ABS-approved drawings and procedures. All supports are to be verified. Upon completion, all systems are to be functionally tested and proven in order.

3.17 Mechanical

All mechanical equipment installation/testing is to be in accordance with ABS-approved drawings and procedures, including the grounding of the equipment. Upon completion, all equipment is to be functionally tested and proven in order.

5 Installation, Hook-up and Commissioning Surveys

Surveys during installation are to be carried out in accordance with approved plans and procedures.

5.1 Installation Surveys

For floating terminals, detailed requirements are contained in Section 3-4-1 of the *FPI Rules*. In general, it is to include the following, where applicable:

- General description of the mooring system and floating terminal
- Pre-installation verification procedures for the sea-bed condition and contingency procedures
- Pile or anchor and mooring line installation procedures
- Tensioning and proof load testing procedures of the anchor piles or anchor-chain system
- Hook-up of the anchor chain system to the floating terminal
- For disconnectable mooring system, procedures for the disconnecting and connecting of the floating terminal's mooring system
- Final field erection and leveling
- Pre-tensioning of mooring system

5.3 Commissioning Surveys

The commissioning date will be the date on which a Surveyor issues the Interim Classification Certificate for the offshore liquefied gas terminal. Commissioning of all Rule-required systems is to be verified by the attending ABS Surveyor. The commissioning is to be in accordance with the approved step-by-step commissioning procedures. The Surveyor is to be permitted access to critical/hold points to verify that the procedures are satisfactorily accomplished. The Surveyor is to observe the terminal operating under various capacities and conditions.

Approved liquefied gas and GNG transfer operations including emergency procedures are to be verified to the extent deemed necessary by the attending Surveyor. The overall performance of the liquefied gas containment system should be verified for compliance with the design parameters during the initial cool-down, loading and discharge operations. Records of all these performance should be maintained and are to be made available to ABS.

Similarly, the safe and satisfactory performance of all process systems covered under the terminal's classification will be verified by the Surveyor as part of the commissioning survey.

5.5 Personnel Safety

Personnel safety precautions which should include checks of operational readiness of all lifesaving, fire and gas detection and fire fighting equipment, ESD systems, unobstructed escape routes and establishment of communication procedures are to be taken during commissioning and are required to be verified by the attending Surveyor. All such emergency procedures should be capable of dealing with any contingencies such as spillage, fire and other hazards.

SECTION 2
Surveys After Construction and Maintenance of Class

1 General

This Section pertains to periodical surveys after construction for the maintenance of classification for floating offshore liquefied gas terminals.

1.1 Notification and Availability for Survey

The Surveyors are to have access to classed Floating Liquefied Gas Terminals at all reasonable times. The Owners or their representatives are to notify the Surveyors on all occasions when a Floating Liquefied Gas Terminal can be examined on site.

The Surveyors are to undertake all surveys on classed Floating Liquefied Gas Terminals upon request, with adequate notification, of the Owners or their representatives and are to report thereon to the Committee. Should the Surveyors find occasion during any survey to recommend repairs or further examination, notification is to be given immediately to the Owners or their representatives in order that appropriate action may be taken. The Surveyors are to avail themselves of every convenient opportunity for performing periodical surveys in conjunction with surveys of damages and repairs in order to avoid duplication of work. Also see 1-1-8/3 of the *ABS Rules for Conditions of Classification - Offshore Units and Structures (Part 1)*.

3 Surveys

3.1 Annual Survey

An Annual Survey of the terminal is to be carried out within three (3) months before or after each annual anniversary date of the crediting of the previous Special Periodical Survey or original construction date.

For terminals on Continuous Survey, all Continuous Survey requirements for those parts (items) due are generally to be completed each year. The Annual Survey will not be credited and the Certificate of Classification will not be endorsed unless Continuous Survey items which are due or overdue at the time of the Annual Survey are either completed or granted an extension.

3.3 Intermediate Survey

An Intermediate Survey of the terminal is to be carried out either at or between the second and third Annual Survey after Special Periodical Survey No. 1 and subsequent Special Periodical Surveys.

3.5 Special Periodical Survey

A Special Periodical Survey of the terminal is to be carried out within five (5) years of the initial Classification Survey, and at five-year intervals thereafter.

The Special Periodical Survey may be commenced at the fourth Annual Survey and be continued with completion by the fifth anniversary date. Where the Special Periodical Survey is commenced prior to the fourth Annual Survey, the entire survey is to be completed within 15 months if such work is to be credited to the Special Periodical Survey.

A Special Periodical Survey will be credited as of the completion date of the survey but not later than five years from date of build or from the date recorded for the previous Special Periodical Survey. If the Special Periodical Survey is completed within three (3) months prior to the due date, the Special Periodical Survey will be credited to agree with the effective due date.

Special consideration may be given to Special Periodical Survey requirements in unusual cases. Consideration may be given for extensions of Rule-required Special Periodical Surveys under extreme circumstances.

3.7 Continuous Survey Program

At request of the Owner, and upon approval of the proposed arrangements, a system of Continuous Surveys may be undertaken, whereby the Special Periodical Survey requirements are carried out in regular rotation to complete all of the requirements of the particular Special Periodical Survey within a five-year period. The proposed arrangements are to provide for survey of approximately 20% of the total number of survey items during each year of the five-year period. Reasonable alternate arrangements may be considered.

Each part (item) surveyed becomes due again for survey approximately five (5) years from the date of the survey and the due parts (items) are generally to be completed each year. For Continuous Surveys, a suitable notation will be entered in the *Record* and the date of the completion of the cycle published.

ABS may withdraw its approval for Continuous Survey if the Surveyor's recommendations are not complied with.

3.9 Survey Based on Preventative Maintenance Techniques

A properly conducted preventative-maintenance/condition-monitoring plan may be credited as satisfying the requirements of Special Continuous Survey. This plan must be in accordance with 7-A1-14 "Survey Based on Preventative Maintenance Techniques" of the *ABS Rules for Survey After Construction (Part 7)*.

3.11 In-line Surveys and Timing of Surveys

All items required to undergo Special Periodical Surveys are to be carried out at the same time and interval in order that they are recorded with the same crediting date. In cases where damage has involved extensive repairs and examination, the survey thereon may, where approved by the Committee, be accepted as equivalent to Special Periodical Survey.

Surveys are to be completed within three (3) months of their due dates, unless extended by agreement with ABS. Surveys carried out within this three-month window period will be credited and due at the same anniversary date in subsequent cycle. When so desired by the Operator/Owner, any part of the terminal installation may be offered for survey prior to the three-month window and the survey will be credited as of the date it has been surveyed.

3.13 Drydocking Surveys

Drydocking Surveys or equivalent UWILDs are to be carried out twice in any five-year period, with an interval not exceeding three (3) years. Consideration may be given for extensions of drydocking or UWILD due dates under special circumstances. An underwater inspection by competent diver(s) may be required for such extensions.

Where the terminal is classed as non self-propelled or with the Notation **(Disconnectable) Ⓢ AMS**, the Drydocking Survey is to comply with the requirements stated in 4-2/5.7 of this Guide. An approved UWILD may be considered equivalent to an out-of-water drydocking for terminals up to and including Special Periodical Survey No. 4 or twenty (20) years of age, whichever is reached earlier. For each drydocking or equivalent UWILD after Special Periodical Survey No. 4, requests to conduct a UWILD in accordance with previously approved plans are to be submitted for consideration well in advance of the proposed survey. For detailed requirements of the UWILD, refer to Section 7-3-1 of the *FPI Rules*. Approvals to conduct the UWILD after Special Periodical Survey No. 4 are to be made available onboard for the Surveyor's reference.

Where the terminal's self-propulsion system is classed with the notation **Ⓢ AMS**, it would be treated similarly to a trading liquefied gas carrier. For these terminals, the Drydocking Survey is to comply with the requirements stated in Section 7-4-1 of the *ABS Rules for Survey After Construction (Part 7)* and UWILD will not be considered equivalent to an out-of-water Drydocking Survey when carried out concurrent with the Special Periodical Survey – Hull. For detailed requirements of the UWILD, refer to Appendix 7-A-1 of the *ABS Rules for Survey After Construction (Part 7)*.

3.15 Boiler Surveys

Where provided, Boiler Surveys of main propulsion boilers are to be carried out at intervals defined in 7-2-1/17 of the *ABS Rules for Survey After Construction (Part 7)*.

Waste-heat or fired auxiliary boilers intended for working pressures above 3.4 bar (3.5 kgf/cm², 50 psi), are to be surveyed two times in any five-year period, with an interval not exceeding three (3) years between Boiler Surveys.

Consideration may be given for extensions of Rule-required Boiler Surveys. The extension may be granted by the Surveyor, provided a survey is carried out in accordance with 7-7-1/7 of the *ABS Rules for Survey After Construction (Part 7)*.

3.17 Tailshaft/Tubeshaft Surveys

A Tailshaft or Tubeshaft Survey of self-propelled terminals are to be carried out at intervals defined in 7-2-1/13 of the *ABS Rules for Survey After Construction (Part 7)*. However, due to low running hours, this interval may be extended. For details, refer to 4-2/5.5 of this Guide.

5 Survey Reports File

All survey reports and records of all abnormalities found are to be compiled into the Survey Report File that is to be kept onboard the Floating Liquefied Gas Terminal at all times for reference during any survey. The records to be kept include, but are not limited to, the following:

- i) Approved Survey and Inspection Plan, as required by 2-1/13.15 of this Guide.
- ii) The updated status records of all class surveys.
- iii) The records of all abnormalities found that are to include all videos and photographic records.
- iv) The records of all repairs performed on any abnormalities found and any further repetitive abnormalities found subsequent to the repairs.
- v) Records of all corrosion protection system maintenance, including records of all cathodic potential readings taken, records of depletion of all sacrificial anodes, impressed current maintenance records, such as voltage and current demands of the system, coating breaks and the monitoring records of the steel material wastage in way of the coating break areas.
- vi) All classification reports pertaining to the Floating Installation.
- vii) All records of any findings of abnormalities by the crew personnel onboard, including all leakages in bulkheads and piping.

- viii) Reports of thickness measurements of the floating terminal structure.
- ix) Reports of all NDT performed.

5.1 Annual Survey

At each Annual Survey, in addition to a general review of the maintenance records, the Surveyor is to verify the effectiveness of the following items by visual examination and operational testing, as appropriate:

5.1.1 Hull Structure for Ship- or Barge-type Terminals

- i) The weather decks, hull plating and its closing appliances together with watertight penetrations are to be generally examined as far as practicable.
- ii) Freeing ports, guard rails, lifelines, gangways and deck houses.
- iii) Confirmation of loading guidance and stability data, as applicable. Loading instruments accepted for classification are to be confirmed in working order by use of the approved check conditions.
- iv) Confirmation that no structural alterations have been made which would affect the calculation determining the position of the load lines. The Load Line marks are to be sighted, found plainly visible and recut and/or painted, as required.
- v) Arrangement of structural fire protection, operation of manual and/or automatic fire doors, if fitted, and the means for escape from the accommodations, machinery spaces and other spaces are satisfactory.
- vi) Suspect areas of the hull are to be examined, including an overall and Close-up Survey of those suspect areas which were identified at previous Special Periodical or Intermediate Survey. For further details regarding survey of suspect areas and examination of salt-water spaces, refer to the 7-3-2/1.1.9 of the *ABS Rules for Survey After Construction (Part 7)*.
- vii) Where areas of the terminal are designated for helicopter operations, the helicopter deck, deck supporting structure, deck surface, deck drainage and safety netting or equivalent are to be examined.
- viii) Any novel features incorporated in the design of the terminal in accordance with procedures agreed to by ABS during design review.
- ix) Particular attention is to be given to significant modifications or repairs made as a result of findings at time of previous survey.

5.1.2 Hull Structure for Other Type Terminals

Annual Survey of hull for structures other than ship- or barge-type terminals are to be in accordance with an approved Survey and Inspection Plan defined in 4-2/7 of this Guide.

5.1.3 Equipment and Machinery

- i) Equipment/machinery with their associated pumps, piping, electrical installations are to be generally examined as accessible.
- ii) Machinery and boiler space(s), bilge pumping system including bilge wells and associated alarms are to be generally examined and bilge alarms to be tested.
- iii) Boilers and pressure vessels and their external appurtenances including safety devices, foundations, controls, relieving gear, high pressure and escape steam piping, insulation and gauges are to be examined.
- iv) Means to bring the machinery into operation (dead ship starting arrangement) as required by 4-8-2/3 of the *Marine Vessel Rules*.

- v) Main propulsion gear-tooth contact is to be examined at the time of the first Annual Survey after floating terminal enters service, or after replacement gears have been placed in service. For further details, refer to 4-3-1/9.9 of the *Marine Vessel Rules*.
- vi) Accessible parts of the steering arrangements together with an operational test of the main and auxiliary steering gear while the terminal is on-site.
- vii) Testing of all means of communication between the steering control stations.

5.1.4 Electrical, Instrumentation and Control Systems

- i) Electrical installation, emergency sources of power, switchgears and other electrical equipment. The operation of the emergency sources of electrical power and their automatic operation are to be confirmed as far as practicable.
- ii) Precautions against electric shocks, fire and other hazards of electrical origin are to be generally examined.
- iii) Electrical equipment installed in hazardous or gas dangerous spaces delineated in the ABS-approved plan are to be generally examined as accessible.
- iv) Instrumentation and control equipment with their associated electrical cabling, are to be generally examined.

5.1.5 Containment Systems

- i) Survey of the containment system is to be carried out in line with the applicable requirements of ABS' Annual Survey for liquefied gas carriers. (Refer to 7-3-2/1.13.7 of the *ABS Rules for Survey After Construction (Part 7)* for details)
- ii) Inerting system installed in accordance with Section 5C-8-9 of the *Marine Vessel Rules* is to be examined and tested in accordance with 7-6-2/1.1.12 of the *ABS Rules for Survey After Construction (Part 7)*.

5.1.6 Safety Systems

- i) General examination of the safety systems is to be carried out as far as practicable. These systems include but are not limited to: gas detection, fire detection, fire extinguishing, structural fire protection and emergency shutdown systems.
- ii) Personnel protection and life saving appliances and means of escape are to be examined as far as practicable.
- iii) Fire-extinguishing equipment as outlined in the *Marine Vessel Rules*, including examination and/or test of the following:
 - a) Fire main system including isolating valves and hydrants
 - b) Fire/emergency fire pumps
 - c) Fire hoses, nozzles, applicators and spanners
 - d) Semi-portable and portable fire extinguishers
 - e) Fire Control Plans, where required
 - f) International Shore Connection
 - g) Fixed fire-fighting system controls, piping, instructions and marking
 - h) Remote controls for stopping fans/machinery and shutting off fuel supplies in machinery spaces
 - i) Fireman's outfits
 - j) Closing arrangements of funnel annular spaces, skylights, doorways, tunnels, and machinery ventilation system

- iv) Access doors and ventilation systems serving the hazardous or gas dangerous spaces, and associated alarms.
- v) Where areas of the terminal are designated for helicopter operations and where fitted, the following are to be generally examined:
 - a) Access arrangements, ventilation, and electrical equipment
 - b) Fuel storage and refueling system including tank, pumps, piping, valves, vent, sounding, overflow, spill containment and remote shutdowns

5.1.7 Mooring System

The spread mooring system is to be generally examined so far as can be seen and placed in satisfactory condition as necessary. In addition, the following above-water items are to be examined, placed in satisfactory condition and reported upon, where applicable:

- i) The anchor chain stopper structural arrangements are to be visually examined, including the structural foundations of all the stoppers or holders. Tensioning equipment is to be generally examined.
- ii) The anchor chain catenary angles are to be measured to verify that the anchor chain tensions are within the design allowable tolerances. Where anchor cables are used, their tensions are to be verified to be within the allowable tensions.
- iii) The anchor chains or anchor cables above the water are to be visually examined for wear and tear.

Annual Survey of mooring systems other than spread mooring design is to be specially agreed upon by ABS and to be in accordance with the requirements stated in ABS-approved Survey and Inspection Plan.

5.1.8 Additional Requirements

- i) Where the terminal's process and/or support system is classed with ABS, the survey of the systems is to be carried out considering the extent of classification defined within the Class Notation assigned to the terminal, and in line with the applicable requirements of ABS' Annual Survey for Facilities on Offshore Installations. For details, refer to 5-2/7.1 of the *Facilities Rules*.
- ii) Where the terminal's automatic and remote control and monitoring system is approved for **ACC**, **ACCU**, **AMCC** or **AMCCU** Class Notation, the system is to be generally examined while the terminal's service generators are in operation and control systems are energized. For further details, refer to the *Marine Vessel Rules*.
- iii) Where the terminal's import and export system is classed with ABS, the survey of the system is to be carried out in accordance with the requirements of Section 7-7-1 of the *FPI Rules*.
- iv) Where parts (items) of the terminal are approved for "Surveys based on Preventive Maintenance Techniques", each such part due or overdue at the time of the Annual Survey is to be examined/tested as required by the Surveyor.
- v) Where parts (items) of the terminal are approved for "Continuous Surveys", each such part due or overdue at the time of this Annual Survey is to be examined/tested as required by the Surveyor.
- vi) Where parts (items) of the terminal are approved for "Risk-Based Inspection" (RBI), each such part due or overdue at the time of this Annual Survey is to be examined/tested in accordance with the ABS approved RBI Plan.
- vii) Maintenance Records, to establish the updated scope and content of the required surveys to be carried out by ABS Surveyors, are to be reviewed. Changes (if any) to the

maintenance procedures and their frequency informed by the Operator/Owner are to be reviewed by the Surveyor or requested to be submitted to appropriate ABS technical office for review.

Because of the varied nature and purposes of offshore liquefied gas terminals, the above requirements are to be considered as the general scope of required surveys. Additional surveys defined in the ABS approved “Survey and Inspection Plan” (See 4-2/7 of this Guide) are to be carried out to confirm the fitness of the terminal for satisfactory continuous operation.

5.3 Intermediate Survey

In addition to the requirements of the Annual Survey, the Intermediate Survey is to include sufficient examination, tests and checks carried out by the Surveyors to satisfy themselves that the hull is found or placed in satisfactory condition and in compliance with the applicable Rule requirements. The Intermediate Survey for ship- or barge-type terminals is to include the following:

- i)* For terminals over five (5) years of age, an overall survey of a minimum of three (3) representative salt water ballast tanks selected by the Surveyor is to be carried out. Where POOR coating condition is found, where soft coating has been applied or where a protective coating has not been applied, the examination is to be extended to other ballast spaces of the same type.
- ii)* For floating terminals more than 10 years of age, an Overall Survey of all ballast spaces.
- iii)* If such examinations reveal no visible structural defects, the examination may be limited to a determination that the protective coating remains effective.
- iv)* In salt water ballast spaces other than double bottom tanks where POOR coating condition is found and Owners or their representatives elect not to restore the coating, where a soft coating has been applied or a protective coating has not been applied, the ballast tanks are to be internally examined at each subsequent Annual Survey with thickness measurements carried out as considered necessary.
- v)* In double bottom salt water ballast tanks where POOR coating condition is found and Owners or their representatives elect not to restore the coating, where a soft coating has been applied or a protective coating has not been applied, internal examination at each subsequent Annual Survey with thickness measurements carried out as considered necessary is required where substantial corrosion is documented.
- vi)* When extensive areas of wastage are found, thickness measurements are to be carried out and renewals made when wastage exceeds the allowable margin. Where reduced scantlings on the basis of effective corrosion control have been adopted, the results of any measurements are to be evaluated based on scantlings before reduction.

Intermediate Survey of hull for structures other than ship- or barge-type terminals are to be in accordance with an approved Survey and Inspection Plan defined in 4-2/7 of this Guide.

5.5 Special Periodical Survey

The Special Periodical Survey is to include all items listed under the Annual Survey with more comprehensive examination and testing of the terminal’s structure, machinery, equipment, fire protection/ fighting/extinguishing systems, cargo containment and transfer systems and mooring system. The Special Periodical Survey is to be carried out in conjunction with the associated UWILD Survey.

At each Special Periodical Survey for ship- or barge- type terminals, in addition to a general review of the maintenance records and where applicable and required for Classification of the terminal, the Surveyor is to verify the effectiveness of the following items by visual examination and operational testing, as appropriate:

5.5.1 Hull Structure

- i)* A Drydocking Survey or equivalent UWILD is to be carried out in accordance with 4-2/5.7 of this Guide.

ii) All decks, watertight bulkheads, and internal and external surfaces of shell plating are to be examined. Plating in way of side shell or superstructure portlights is to be especially examined.

iii) An Overall Survey of all spaces; double bottom, deep, ballast, peak and cargo tanks; pump rooms, pipe tunnels, duct keels, machinery spaces, dry spaces, cofferdams and voids, bilges and drain wells, sounding, venting, pumping and drainage arrangements.

This examination is to be supplemented by thickness measurement and testing, as deemed necessary, to ensure that the structural integrity remains effective. The examination is to be sufficient to discover substantial corrosion, significant deformation, fractures, damages or other structural deterioration.

iv) Engine room structure is to be examined. Particular attention is to be given to tank tops, shell plating in way of tank tops, brackets connecting side shell frames and tank tops, and engine room bulkheads in way of tank top and bilge wells.

Particular attention is to be given to the sea suction, seawater cooling pipes and overboard discharge valves and their connection to the side shell plating. Where extensive areas of wastage are found, thickness measurements are to be carried out, and renewals and/or repairs made when wastage exceeds allowable margins.

v) In salt water ballast spaces other than double bottom tanks where POOR coating condition is found and Owners or their representatives elect not to restore the coating, where soft coating has been applied or where a protective coating has not been applied, the ballast tanks, where fitted, are to be internally examined and thickness measurements carried out as deemed necessary by the Surveyor at each subsequent Annual Survey.

When such coating conditions are found in double bottom salt water ballast tanks, internal examinations at each subsequent Annual Survey is required where substantial corrosion is documented. When deemed necessary by the Surveyor or where extensive corrosion exists, thickness measurements are to be carried out.

vi) Internal examination requirements will be specially considered for lube oil tanks and for tanks used exclusively for permanent ballast which are fitted with an effective means of corrosion control.

Where double bottom and other tanks, except for the peak tanks, are used primarily for heavy fuel oil or exclusively for light oils, the internal examination may be waived, provided that upon a general external examination of the tanks, the Surveyor finds their condition to be satisfactory.

In addition to the general external examinations, the following internal examinations are to be carried out and found satisfactory as a condition of waiving the internal examination of the remaining fuel oil tanks.

- At Special Periodical Survey No. 3 - one forward fuel oil double bottom
- At Special Periodical Survey No. 4 and 5 - one fuel oil double bottom forward, one in vicinity of amidships, and one aft
- At Special Periodical Survey No. 6 and subsequent Special Periodical Surveys - one fuel oil double bottom in way of each cargo hold

Independent oil tanks in machinery spaces are to be externally examined and, if deemed necessary, tested under a head of liquid.

vii) All tank protective devices, where fitted, are to be examined externally for proper assembly and installation, damage, deterioration or traces of carryover at the outlets.

All pressure-vacuum valves and pressure relief valves are to be opened out, pressure and vacuum valve discs checked for good contact with their respective seats and/or proved by testing.

- viii) All airpipes are to be opened out and the condition of closing arrangements and flame screens, if fitted, verified.

5.5.2 Hull Thickness Measurement Requirements

- i) Thickness measurements are to be carried out in accordance with the requirements stated in the 7-3-2/5.1 of the *ABS Rules for Survey After Construction (Part 7)* as applicable to liquefied gas carriers over 90 meters (295 feet) and over in length. Minimum requirements for thickness measurements at Special Periodical Surveys are to be in accordance with the requirements stated in the 7-3-2/5.1.14 of the *ABS Rules for Survey After Construction (Part 7)* as applicable to liquefied gas carriers over 90 meters (295 feet) and over in length.

The extent and method to be employed in the gauging process is to be in accordance with an approved Survey and Inspection Plan.

Thickness measurements taken during or after the fourth Annual Survey will be credited towards the Special Periodical Survey. Where extensive areas of wastage are found, the Surveyor may require further thickness measurements as deemed necessary. Renewals are to be made when wastage exceeds allowable margins.

Where substantial corrosion is found, additional thickness measurements are to be taken to confirm the extent of substantial corrosion.

Where reduced scantlings on the basis of effective corrosion control have been adopted, the results of any gaugings are to be evaluated based on the scantlings before reduction.

Transverse sections are to be chosen based upon cargo/ballast history, arrangement and condition of coatings. Thickness measurement locations are to be chosen from areas likely to be most exposed to corrosion effects, (i.e., typically in way of ballast tanks) or are revealed from deck plating thickness measurements.

The thickness measurement requirements in way of internals may be modified by the attending Surveyor if the corrosion prevention system remains in GOOD or FAIR condition.

The Surveyor may require further thickness measurements as deemed necessary.

- ii) Where the terminal is classed with the notation **(Disconnectable) ⓧ AMS** or **ⓧ AMS**, the boundaries of double-bottom, deep, ballast, peak and other integral tanks are to be tested with a head of liquid. Where the terminal is classed as non self-propelled, such boundaries are to be subject to visual examination and only if suspect may be required to be tested with a head of liquid, subject to NDE or thickness gauging, as deemed necessary by the attending Surveyor.

The testing of double bottoms and other spaces not designed for the carriage of liquid may be omitted, provided that a satisfactory internal examination together with an examination of the tanktop is carried out. The Surveyor may require further tank testing as deemed necessary.

- iii) (1 September 2012) Individual plate and stiffener wastage allowances – Individual plate and stiffener wastage allowances for floating terminals with design life of 20 years are to satisfy Appendix 7-A-4 of the *ABS Rules for Survey After Construction (Part 7)*. Local wastage allowable margins of plates and stiffeners for floating terminals with design life longer than 20 years will remain the same as applied to the required 20 year life

scantlings to determine minimum scantlings at which renewals are required. Accordingly, based on percent wastage allowance, renewals would be required when scantling were wasted to values as if the terminal were a 20 year life terminal. The allowable wastage is to be based on the smaller of the percent wastage allowance, or the allowable wastage based on local buckling strength.

5.5.3 Equipment and Machinery

- i) All openings to the sea, including sanitary and other overboard discharges together with the valves connected therewith, are to be examined internally and externally.
- ii) The emergency fire pump nonreturn valve (if fitted) is to be examined internally and externally.
- iii) Pumps and pumping arrangements, including valves, cocks, pipes, strainers and nonmetallic flexible expansion pieces in the main circulating system are to be examined.
- iv) Operation of the bilge/dewatering system. Other systems are to be tested as considered necessary.
- v) The foundations of main and auxiliary machinery are to be examined.
- vi) Heat exchangers and other unfired pressure vessels with design pressures over 6.9 bar (7 kgf/cm², 100 psi) are to be examined, opened out and pressure tested as deemed necessary, and associated relief valves proven operable. Evaporators that operate with a vacuum on the shell need not be opened, but may be accepted on basis of satisfactory external examination and operational test or review of operating records.
- vii) Air compressors, air reservoirs and associated piping are to be examined. If air reservoirs cannot be examined internally, they are to be hydrostatically tested. All relief valves and safety devices are to be proven operable.
- viii) Where provided, examination of the steering machinery is to be carried out, including an operational test and checking of relief-valve settings. Further, a hydrostatic check of the steering system to the relief valve setting is to be conducted, using the installed power units.
- ix) Where provided, reduction gearing is to be opened and examined as deemed necessary by the Surveyor in order to confirm the condition of the gears, pinions, shafts, bearings and lubrication system. Alternative means of ascertaining the condition of epicyclic gearing will be specially considered.
- x) Where provided, steam reciprocating engines are to be opened and examined, including cylinders, pistons, valves, valve gear, crossheads, crankpins, main journals and thrust bearing.
- xi) Where provided, main and auxiliary steam condensers are to be opened, examined and leak tested as deemed necessary by the Surveyor.
- xii) Where provided, main steam piping is to be examined. Where deemed necessary by the Surveyor, the thickness is to be ascertained by NDE. Alternatively, for an installation operating at temperatures not exceeding 427°C (800°F), hydrostatic tests to 1.25 times the working pressure may be accepted.
- xiii) For operational testing of main and auxiliary machinery, see appropriate sections of the *Marine Vessel Rules*, as applicable.
- xiv) Where provided, main and auxiliary internal combustion engines are to be opened, examined and measured, as applicable, in accordance with 7-6-2/3.1.2 of the *ABS Rules for Survey After Construction (Part 7)*.

Parts which have been examined within fifteen months need not be examined again, except in special circumstances. Special consideration as to the requirements for Special

Periodical Surveys may be given for main engines with bores 300 mm (11.8 inches) or under, provided the engine is maintained under a manufacturer's scheduled maintenance program. The records of the program, including lubrication servicing, are to be made available to the Surveyor. Periodical overhauls, required by the manufacturer's scheduled maintenance program, are to be witnessed by the Surveyor and will be accepted for completion of the cycle.

- xv) Where provided, gas turbines are to be opened and maintained in accordance with manufacturer's recommendations as appropriate for the actual applicable operating conditions. Owners are to submit for approval maintenance schedules for each type of gas turbine in service specifying proposed intervals for combustion checks, hot-gas-path examinations and major examinations. Upon approval, the schedules will become part of the Special Periodical Survey - Machinery records.

For units in continuous service, at least one hot-gas-path examination is to be scheduled each survey cycle and is to include an examination of turbine rotors, fixed blading, combustors, inlet casings (including demisters and filters), exhaust casing including regenerator, air control valves and protective apparatus. Other parts and associated equipment as may be deemed necessary by the attending Surveyor are to be opened up for examination. Opening of compressor sections is to be scheduled in conjunction with major examinations, provided that examination of the blades visible from the inlet plenum during the hot-gas-path examination reveals no evidence of defects. The required examinations of auxiliary gas turbine units, at least once each cycle, are to be based on manufacturer's recommendations, as appropriate for the actual operating hours and conditions, together with an operation test including protective apparatus. Where units are arranged such that the unit is removed from the terminal and dismantled at another facility, the internal examination may be carried out at the facility. The reinstallation is to be carried out to the satisfaction of the Surveyor.

5.5.4 Electrical, Instrumentation and Control Systems

- i) Fittings and connections on main switchboards and distribution panels.
- ii) Electric cables, as far as practicable.
- iii) Generators, including emergency generator, are to be run under load. Where the generators are arranged to operate in parallel, satisfactory load sharing and operation of the circuit breakers, including the reverse power trip, is to be demonstrated.
- iv) The insulation resistance of the circuits is to be measured between conductors and between conductors and earth and these values compared with those previously measured.
- v) Where electrical auxiliaries are used for vital purposes, the generators and motors are to be examined and their prime movers opened for examination. The insulation resistance of each generator and motor is to be measured with all circuits of different voltages above earth being tested separately and in accordance with 7-6-2/3.1.2 of the *ABS Rules for Survey After Construction (Part 7)*.
- vi) On the occasion of major repairs, the coils repaired or renewed are to be subjected to a dielectric strain test, as specified under the applicable parts of 4-8-3/3.15 of the *Marine Vessel Rules*. In addition, the circuits containing the repairs or renewals and coils which have been disturbed during repairs are to be subjected to dielectric strain tests for one minute by application of a potential of 125% of the maximum operating voltage of the circuits to which it is applied. The DC fields of generators and motors are to be subjected for one minute to a test potential equal to 50% of the value specified under the applicable parts of 4-8-3/3.15 of the *Marine Vessel Rules*, and the whole apparatus operated under full-load conditions.

5.5.5 Containment Systems

- i) Survey of the containment system is to be carried out in line with the applicable requirements of ABS' Special Survey for liquefied gas carriers. For details, refer to 7-3-2/5.11 of the *ABS Rules for Survey After Construction (Part 7)*.
- ii) The inerting system installed in accordance with 5C-8-9 of the *Marine Vessel Rules* is to be examined and tested in accordance with 7-6-2/3.1.1 of the *ABS Rules for Survey After Construction (Part 7)*.

5.5.6 Mooring System

Since it is impractical to cover all types of mooring systems, the following are provided as guidance to show the basic intent of the requirements. Operators and designers may submit alternative survey requirements, based either on service experience or manufacturer's recommendations. Upon review and if found acceptable, these alternative survey procedures will form the basis for the Special Periodical Survey of the Mooring System.

In addition to the requirements of the Annual Survey, the Special Periodical Survey is to include the following, where applicable:

- i) A survey of the entire mooring system is to be performed in drydock or during equivalent UWILD. Any suspect areas where excessive corrosion is evident are to be thickness gauged.
- ii) An examination is to be made on all anchor chains for excessive corrosion and wastage. In particular, the areas to be specially examined are the areas having the most relative movement between the chain links. These areas are normally located in way of the seabed touchdown sections of the catenary part of the chains. Corrosion and wastage allowances defined and agreed upon by ABS are to be made available to the attending Surveyor prior to conducting any measurements.
- iii) The chains are to be inspected for loose studs and link elongations. Sufficient representative locations are to be gauged for wear and wastage. Areas susceptible to corrosion, such as the wind-and-water areas, are to be specially gauged, if considered necessary by the attending Surveyor.
- iv) A close examination is to be performed on all mooring components and accessible structural members that carry the mooring loads. These structural members include the chain stoppers or cable holders, the structures in way of the chain stoppers or cable holders, structural bearing housing and turret/structural well annulus areas. These structures are to be thoroughly cleaned and examined and any suspect areas are to be nondestructively tested.
- v) A general inspection is also to be carried out on the degree of scour or exposure in way of the anchor or anchor piles to ascertain that these components are not overexposed.
- vi) The chain tensions are to be checked and where found not in compliance with the specifications are to be readjusted accordingly. Excessive loss of chain or tendon tensions are to be investigated.
- vii) For disconnectable type mooring systems, the disconnect and connect system for the mooring system is to be tested as considered necessary by the attending Surveyor. Alternatively, records of disconnect/connect operations between the credit date of the last Special Periodical Survey and the current due date of same may be reviewed, and if found satisfactory, it may be considered to have been in compliance with this requirement.

5.5.7 Additional Requirements

- i) Where the terminal's process and/or support system is classed with ABS, the survey of the system is to be carried out considering the extent of classification defined within the Class Notation assigned to the terminal, and in line with the applicable requirements of

ABS' Special Periodical Survey for Facilities on Offshore Installations. For details, refer to 5-2/7.3 of the *Facilities Rules*.

- ii) Where the terminal's automatic and remote control and monitoring system is approved for **ACC**, **ACCU**, **AMCC** or **AMCCU** Class Notation, in addition to the applicable requirements of the Annual Survey [refer to 4-2/5.1.7.ii) above], all mechanical, hydraulic and pneumatic control actuators and their power systems are to be examined and tested, insulation resistance readings are to be taken, automatic controls are to be tested, and the entire control system is to be subjected to a trial at reduced power to ascertain proper performance of the automatic functions, alarms and safety systems. For details, refer to Section 7-8-2 of the *ABS Rules for Survey After Construction (Part 7)*.
- iii) Where the terminal's import and export system is classed with ABS, the survey of the system is to be carried out in accordance with the requirements of Section 7-7-2 of the *FPI Rules*.

Because of the varied nature and purposes of offshore liquefied gas terminals, the above requirements are to be considered as the general scope of required surveys. Therefore, additional surveys defined in the ABS approved "Survey and Inspection Plan" (See 4-2/7 of this Guide) are to be carried out to confirm the terminal remains in compliance with the applicable Rule requirements and other relevant standards.

5.7 Drydocking Survey

Where the terminal is classed as self-propelled with the Notation **⊗AMS**, Drydocking Survey is to be carried out in accordance with 7-4-1/1 of the *ABS Rules for Survey After Construction (Part 7)*.

Where the terminal is classed as non self-propelled or with the notation **(Disconnectable)⊗AMS**, Drydocking Survey including the terminal's structural condition, corrosion protection system, mooring system and its import and export system (if classed by ABS), is to include the following:

5.7.1 UWILD

- i) UWILD is to be carried out in accordance with documented procedures that have been submitted for review and approved by ABS in advance of the survey. The approved procedure is to be made available onboard the terminal. Approvals to conduct the UWILD after Special Periodical Survey No. 4 are also to be made available onboard for the Surveyor's reference.
- ii) The UWILD procedure is to consist of the following:
 - Procedure for divers to identify the exact location at which they are conducting their inspection
 - Procedure for cleaning the marine growth for inspection purposes that is to include the extent and location of the underwater cleaning
 - Procedure and extent for measuring the cathodic potential readings in way of the structures
 - Procedure and extent for taking thickness gaugings of the structures and NDT of critical joints
 - Qualifications of all divers conducting the inspection, NDT and thickness gaugings
 - Type of underwater video and photography, including means of communication, monitoring and recording
- iii) As applicable, the keel, stem, stern frame, rudder, propeller, and outside of side and bottom plating are to be cleaned as necessary and examined, together with bilge keels, thrusters, exposed parts of the stern bearing and seal assembly, sea chest, rudder pintles and gudgeons, together with their respective securing arrangements.

- iv)* All sea connections and overboard discharge valves and cocks, including their attachments to the hull or sea chests, are to be externally examined.
- v)* All non-metallic expansion pieces in the sea-water cooling and circulating systems are to be examined both externally and internally.
- vi)* As applicable, the stern bearing clearance or wear and rudder bearing clearances are to be ascertained and reported on.
- vii)* For UWILD associated with Special Periodical Survey, means are to be provided to permit the opening up of all sea valves and overboard discharges for internal examination. In addition, all Special Periodical Survey items related to the underwater portion of the hull or structure, including the gauging requirements, are to be dealt with during the underwater survey.

5.7.2 Corrosion Protection System

In addition to the above requirements, the following are to be performed:

- i)* Cathodic potential readings are to be taken from representative positions on the entire underwater body and evaluated to confirm that the cathodic protection system is operating within design limits.
- ii)* Sacrificial anodes are to be examined for depletion and placed in satisfactory condition as considered necessary.
- iii)* Impressed current system anodes and cathodes are to be checked for damage, fouling by marine growth and carbonate deposits. The current and voltage demands of the system are to also be checked to ensure the system is functioning properly.
- iv)* Additional examinations are to be performed on the wind and water areas of the structures where coating breaks are evident. Thickness measurements in these areas may be required if found necessary by the attending Surveyor.

5.7.3 Mooring System

For mooring systems, the following are to be cleaned and examined, where applicable:

- i)* The mooring anchor chain or cable tensions are to be measured, and the end connections of these components are to be examined. All mooring chains are to be generally examined for their entire lengths. Anchors, cables and their respective handling means are to be examined.
- ii)* The buoyancy tanks are to be cleaned and examined, if applicable.
- iii)* Chain and stopper assemblies are to be cleaned, examined and NDT performed as considered necessary by the attending Surveyor.
- iv)* Areas of high stress or low fatigue life are to be preselected, cleaned and NDT performed, if considered necessary.
- v)* Scour in way of anchors or anchor piles is to be examined.
- vi)* Cathodic potential readings are to be taken from representative positions on the entire underwater structure of the mooring system to confirm that the cathodic protection system is operating within design limits.
- vii)* Highly stressed, high wear and tear areas of the mooring chain are to be closely examined and nondestructively tested, if found necessary by the attending Surveyor. These include areas in way of the stoppers and sea bed touchdown areas.

5.7.4 Import and Export System

Where the terminal's import and export system is classed with ABS, the following items are to be cleaned and examined, where applicable:

- i) The entire riser system.
- ii) The arch support buoyancy tanks, their structures and the clamping devices.
- iii) The flexible riser, including all end flanges and bolting arrangements, and spreader bars, if applicable.
- iv) The entire export flexible system is to be examined for damage due to chafing and fatigue fractures.
- v) Hoses designed and manufactured based on OCIMF standards are to be tested in accordance with the OCIMF Guide for the Handling, Storage, Inspection and Testing of Hoses in the Field.
- vi) All navigation aids are to be examined and functionally tested

5.9 Boiler Survey

Boiler Survey is to comply with the requirements stated in Section 7-7-1 of the *ABS Rules for Survey After Construction (Part 7)*.

5.11 Tailshaft/Tubeshaft Survey

Where the terminal is classed with the notation **(Disconnectable) ✕ AMS**, the Tailshaft or Tubeshaft Survey is to comply with the applicable requirements stated in Sections 7-5-1 and 7-5-2 of the *ABS Rules for Survey After Construction (Part 7)*. However, due to low running hours, this interval may be extended based on the following being carried out, as applicable, to the satisfaction of the attending Surveyor:

- i) Diver's external examination of stern bearing and outboard seal area, including wear-down check as far as is possible.
- ii) Examination of the shaft area (inboard seals) in propulsion room(s).
- iii) Confirmation of lubricating oil records (satisfactory oil loss rate, no evidence of unacceptable contamination).
- iv) Shaft seal elements are to be examined/replaced in accordance with seal manufacturer's recommendations.

7 Survey and Inspection Plan

The requirements of 4-2/5.1 above are intended to define the general scope of required surveys. Because of the varied nature and purposes of offshore terminals, it is not considered practicable to establish a firm schedule of requirements. The periodical surveys are to be carried out in accordance with the reviewed Survey and Inspection Plan to confirm the terminal remains in compliance with the applicable Rule requirements and other relevant standards. The Survey and Inspection Planning Document should cover all surveys for the design life of the terminal.

9 Modifications

When it is intended to carry out any modifications to the liquefied gas containment system, process systems, machinery, piping, equipment, etc., which may affect classification, the details of such modifications are to be submitted for review. If ABS determines that the modification will affect classification, the terminal to be modified will be subject to the review, testing and inspection requirements of this Guide.

11 Damage and Repairs

11.1

If an offshore liquefied gas terminal that has been classed suffers any damage to terminal structure, liquefied gas containment system, classed process systems, machinery, piping, equipment, etc. which may

affect classification, ABS is to be notified and the damage examined by a Surveyor. Details of intended repairs are to be submitted for approval, and the work is to be carried out to the satisfaction of the attending Surveyor.

11.3

When a piece of machinery, piping or process equipment suffers a premature or unexpected failure and is subsequently repaired or replaced without Surveyor attendance, details of the failure, including damaged parts, where practicable, are to be retained onboard for examination by the Surveyor during the next scheduled visit. Alternatively, the part or parts may be landed ashore for further examination and testing, as required.

11.5

If failures noted in 4-2/11.3 above are deemed to be a result of inadequate or inappropriate maintenance, the maintenance and survey and inspection plan is to be amended and resubmitted for approval.

13 Certification on Behalf of Coastal and Flag States

When ABS is authorized to perform surveys on behalf of a governmental authority, and when requested by the Owner, items as specified by the governmental authority or Owner will be surveyed. Reports indicating the results of such surveys will be issued accordingly. Where the periodicity and types of surveys on behalf of a governmental authority differ from those required by the applicable portions of this Section, the flag State, coastal State or other governmental authority's requirements take precedence.

15 Welding and Replacement of Materials

15.1 Ordinary and Higher Strength Structural Steels

Welding or other fabrication performed on the structural steels listed in 2-1-2/15.9 TABLE 1 and 2-1-2/15.9 TABLE 2 of the ABS *Marine Vessel Rules for Materials and Welding (Part 2)* is to be in accordance with the requirements of Part 2, Chapter 4, of the above referenced Part 2 *Marine Vessel Rules*.

SECTION 3
Risk-based Surveys for Maintenance of Class

1 General

The provisions of this Section contain survey requirements specific to the maintenance of classification for floating offshore liquefied gas terminals for which inspection plans have been developed using risk-based techniques as an equivalent alternative to prescriptive requirements as defined in Chapter 4, Section 2 of this Guide.

1.1 Applicability

While this Section provides risk-based survey requirements as an alternative for maintenance of Class, the Sections on the classification process contained in this Guide are still applicable. Where no specific references or guidance are given in this Section, the relevant requirements of conventional Rules/Guides remain valid.

1.3 Survey Periods

Because of the diverse nature and purposes of offshore terminals and the varied contents of inspection plans likely to be developed as part of an Owner's risk-based approach to Classification, it is not considered practicable to establish a firm schedule of survey requirements in this Section for maintenance of Class.

3 Requirements for Risk-based Survey

3.1 General

Where the risk-based approach is to be adopted, the Owner's proposed maintenance and inspection plans, including details of frequency and extent of activities, are to be submitted for review. Where these plans deviate from the conventional survey requirements described in this Guide, the risk assessment methodology is to specifically address these deviations which are not to result in an unacceptable level of safety or integrity of the terminal. In addition to the maintenance and inspection plans noted above, the following documentation is to be submitted to ABS at least six (6) months before the plan is to be put into effect. This documentation is to establish, at a minimum:

- i)* The basis and methodology employed in the risk-based techniques
- ii)* The means by which the technique is used to establish maintenance plans
- iii)* The means by which the technique is used to update and modify maintenance and inspection plans

iv) The means by which the following items are to be controlled:

- Accident and Non-Conformity Reporting
- Overdue Inspections/Surveys
- Internal Audits and Management Reviews
- Control, Storage and Retention of Documents and Data
- Change Procedures for ABS-approved plans

3.3 Site-Specific Risk Assessment

Where the risk-based approach is to be adopted on offshore liquefied gas terminals, the risk assessment on which the inspection and maintenance plan is based is to be site-specific. If the terminal is to be relocated, the risk assessment is to be reviewed by the Owner and resubmitted to ABS for approval.

5 Surveys

5.1 General

5.1.1 Special Periodical Survey

To credit a Special Periodical Survey based on risk-based inspection techniques, the terminal is to be subject to a Continuous Survey program, whereby the survey of all applicable items is to be carried out on a continuous basis over the five-year Special Periodical Survey cycle. If this program includes a preventative-maintenance/condition-monitoring plan, this plan is to be in accordance with Appendix 7-A-14, “Survey Based on Preventative Maintenance Techniques”, of the *ABS Rules for Survey After Construction (Part 7)*.

5.1.2 Inspection Plan

The inspection plan detailing the timing and extent of activities will be reviewed to establish the scope and content of the Annual and Special Periodical Surveys which are required to be carried out by a Surveyor who will also monitor the Owner’s in-house quality management system required by this Guide. During the service life of the terminal, maintenance and inspection records are to be updated on a continuing basis and be available for reference by the attending Surveyor. The operator is to inform ABS of any changes to the maintenance procedures and their frequencies as may be caused, for example, by changes, additions or deletions to the original equipment.

5.3 Initial Survey

An Initial Survey is to be carried out to confirm that systems and required plans have been properly implemented. The survey is to be carried out a minimum of three (3) months after the date of implementation of the approved plans, but no later than concurrently with the next due Annual Survey.

5.5 Annual Survey

An Annual Survey is to be carried out by a Surveyor within three (3) months before or after each anniversary date of the initial/renewal Classification Survey. The survey is to be carried out in accordance with the approved risk-based inspection plan to confirm the terminal remains in compliance with the applicable Rule requirements and other relevant standards. Where the inspection plan specifically applies ABS Rules, the applicable items are to be complied with.

5.7 Special Periodical Survey

A Special Periodical Survey of the facilities is to be carried out within five (5) years of the initial Classification Survey and at five-year intervals thereafter. The survey is to include all items in the approved risk-based inspection plan listed under the Annual Survey, confirmation of the completion of the

Continuous Survey program, and where the inspection plan specifically applies ABS Rules, the applicable items are to be complied with.

7 Modifications

When modifications to the terminal that may affect classification are to be carried out after the issuance of Classification Certificate, the details of such modifications are to be submitted for review. If ABS determines that the modification will affect classification, the terminal to be modified will be subject to the review, testing and inspection requirements of this Guide. All documentation requirements for review and the design documentation described in Chapter 2, Section 2 of this Guide is to be available to the attending Surveyor at the time of the modifications.

9 Damage and Repairs

The requirements stated in 4-2/11 of this Guide shall apply.

11 Certification on Behalf of Coastal and Flag States

Only when the coastal and/or flag States and/or other governmental authority accept and authorize ABS for Certification based on risk-based inspection techniques, ABS will carry out surveys, as authorized. If the coastal and/or flag States and/or other governmental authority do not accept a risk-based approach, surveys will be carried out in a conventional, prescriptive manner.